

A KNOWLEDGE BASED APPROACH TO SUPPORT THE CONCEPTUAL DESIGN OF ETO PRODUCTS

Nardelli, Miriam (1); Cicconi, Paolo (1); Savoretti, Andrea (1); Raffaelli, Roberto (2); Germani, Michele (1)

1: Università Politecnica delle Marche; 2: Università degli studi eCampus

ABSTRACT

The ever-increasing competitiveness, due to the market globalization, has forced the industries to modify their design and production strategies. A key point is the development of products that fulfil the individual customer needs as close as possible. ETO companies manufacture new products according to the customer technical requirements given in the request for proposal.

Computational Design Synthesis is the research area focused on activities to automate the design phase in the production of products such ETO structures. In this context, Knowledge Based Engineering applications are usually applied to automate design routines and to implement a multidisciplinary product design. Knowledge should be elicited and formalized, so that it can allow the past cases retrieval and the connection between customer specifications and the product configuration tasks. This paper proposes an approach for the rapid definition of the product structure related to a ETO product, including the early cost evaluation in configurations. The research scope aims at defining a framework to support the knowledge repository, which is the Knowledge Based used to design new products and estimate their costs.

Keywords: Design methodology, Design engineering, Embodiment design, Engineer-To-Order, DSM

Contact:

Nardelli, Miriam
Università Politecnica delle Marche
DIISM
Italy
m.nardelli@pm.univpm.it

Cite this article: Nardelli, M., Cicconi, P., Savoretti, A., Raffaelli, R., Germani, M. (2019) 'A Knowledge Based Approach to Support the Conceptual Design of ETO Products', in *Proceedings of the 22nd International Conference on Engineering Design (ICED19)*, Delft, The Netherlands, 5-8 August 2019. DOI:10.1017/dsi.2019.248

1 INTRODUCTION AND STATE-OF-THE-ART

The ever-increasing competitiveness, due to the market globalization, has been forcing the industries to modify their design and production strategies. A key point is the development of products that fulfil the individual customer needs as close as possible. In this context, two different production scenarios are usually applied in industry: Configure To Order (CTO) and Engineer To Order (ETO). While the CTO production is based on already defined configurations (Windheim *et al.*, 2017, Ripperda and Krause, 2017), ETO products are engineered after a request for proposal (RFP) and a committed order. Moreover, ETO products require a considerable effort during the configuration stage, which must precede the cost estimation (Kristianto, *et al.*, 2015).

In the last 20 years, a lot of research has been paying attention to methods for reducing time and cost in the design of ETO products. These research topics concern Design for manufacturing and assembly (Lewis, 2015), Feature Based Costing (Opiyo, 2017) and Design To Cost (Anon, 2007). However, their application in industry is limited by the complex data analysis and the required knowledge formalization. On the other hand, other research issues such as Knowledge-Based Engineering (KBE) (McMahon *et al.*, 2004), artificial intelligence (AI) (Anon, 2016), and Object-Oriented design (La Rocca, 2012) are more applied in the industrial context. In fact, these methods enhance the reuse of design knowledge by automating repetitive tasks and optimization stages.

Generally, Design Automation is the research area focused on activities to automate the design in the offering and production stages. In this context, KBE applications are usually applied to automate design routines avoiding of repetitive tasks (Verhagen *et al.*, 2012). This technology has its roots in Artificial Intelligence (AI) to analyse and solve problems that must face frequently (Zhu, *et al.*, 2017). Despite such tools, it has been observed that many companies just base the process on poor empirical models working by analogy on the basis of the expertise of senior designers and searching for similar past solutions. Formal knowledge is embedded from product documents, drawings and engineering dimensioning algorithms, while tacit knowledge, which is made of implicit rules, comes from the experience of people with technical expertise. Knowledge formalization is a critical issue which involves capturing, representing, and reusing of past design cases (Verhagen *et al.*, 2012). Moreover, the knowledge about design requirements and constraints available during conceptual design phase is often imprecise, approximate or incomplete (Wang *et al.*, 2002).

The motivation of the research concerns the need to face the following problems in cost estimation:

- The resulting cost is strongly affected by the subjectivity of the cost estimator;
- The elaboration of the technical proposal and the commercial offer is time consuming;
- Expertise in a wide area is required;
- Difficulties in retrieving information of past cases;
- Difficulty of connecting information, e.g. customer specifications and BOM;
- Difficulty of making the most economic choices during the product configuration;
- Difficulty of taking into account the whole product life cycle within the proposal.

Even if methods have been already analysed in literature for rapid product configuration and early cost estimation (Raffaelli *et al.*, 2013), a lack of tools still exist in the context of ETO products, where traditional tools are not suitable to support the design activity including new tasks such as parameters optimization (Cicconi *et al.*, 2018) and life cycle analysis. The paper proposes an approach for the rapid definition of the product structure related to a new ETO product, including the early cost evaluation in configurations.

1.1 Research scope and aims

This article moves from the understanding of the efforts and time consumed by the design of the draft project (offer stage) and the awareness that efforts and time spent could be not remunerated by the customer order. Consequently, the main focus of the research is on reducing time and effort in the offer stage, which allows a company to properly manage a greater number of offers in less time. Therefore, it is necessary to consider both technical and cost parameters during the early design phases.

The proposed approach is suitable for products having a good degree of modularity. Hölttä-Otto specifies that a module is an independent building block of a larger system with a specific function and well-defined interfaces (Hölttä-Otto, 2006). Modular products have been defined as machines,

assemblies or components that fulfil various overall functions through the combination of distinct function units (building blocks) or modules (Pahl *et al.*, 2007).

The architecture of a product is the scheme by which the functional elements of the product are arranged into physical blocks and by which the blocks interact. Mostly, products belong to a family of products, i.e. product variants based on a common platform. Product family can be defined as a group of related products that share common features, components, subsystems and yet satisfy a variety of market niches (Simpson, 2017). Product platforms allow to manage product families using shared assets to enable cost-effectiveness. Otto *et al.* (2016) review the main activities for product platform design and examine a set of product platform development processes used at several different companies. Modularity is a crucial part of platform thinking.

The research aims at defining a framework to support the knowledge repository, which is the Knowledge Based used to design new products and estimate their costs. This repository can also support the user in searching new solutions for products analysing the customer requirements. Regarding the cost estimation, the aim is to extend the evaluation to the entire product life-cycle (manufacturing, maintenance, energy consumption, etc.)

2 METHOD AND FRAMEWORK

An approach for reuse company knowledge in order to estimate the costs of new products is here presented for ETO products. Synthetically, it comprises the following 3 steps (Figure 1):

1. Knowledge formalization and representation
2. Support towards a design solution
3. Cost estimation

The first step represents a preparatory phase in which the company knowledge is formalized and represented in order to be reused. Past project data and product knowledge are embedded in a database of product variants and the product architecture is represented by a meta-model in terms of blocks and dependencies. By combining in different ways blocks and dependencies, it is possible to obtain different product variants, aiming at satisfying product requirements.

The second part of the method aims to support the user in finding a technical solution that meets the product requirements. A DSM is proposed for representing and managing the dependencies between each attribute. Therefore, the resulting problem is divided into several sub-problems. Each sub-problem has a reduced size and concerns the assignment of a limited number of attributes. A parameter-based cost estimation follows the attribute assignment. Finally, the cost evaluation is based on cost models which are retrieved by past project data.

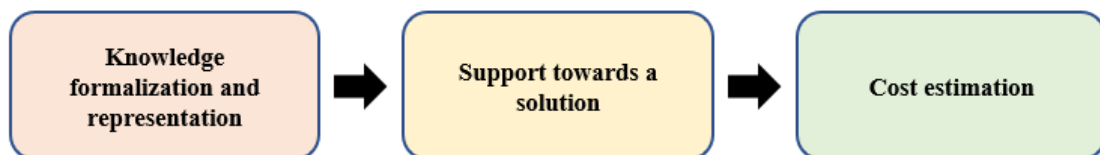

Figure 1 - The method: general scheme

2.1 Knowledge formalization and representation

The functional analysis is the first phase for enhancing the formalization and representation of a Knowledge Base related to a product or a system. This approach is compliant with the principles of Design-To-Cost.

Company knowledge can be formalized in different software tools such as CAD, CAE, PLM, and ERP systems, as highlighted in Figure 2. However, this level of knowledge it is mostly related to its explicit side. Tacit and implicit knowledge, which is the most difficult to be elicited and represented, can be represented in rules and algorithm which are usually implemented in customized Knowledge-Bases Systems.

The proposed framework, described in Figure 2, interacts with different software tools following these functionalities: acquire and manage the product requirements; support the user towards the product configuration; support the user in defining a simplified 3D layout; and define cost models for an early cost estimation.

The proposed framework is to be intended as a part of an integrated environment, which links product knowledge coming from design, manufacturing, marketing, maintenance gathered from the company departments: technical, production, service, commercial and purchasing departments. Managed knowledge extends to the product life cycle, enhancing standardized interfaces to acquire information. Moreover, the proposed framework needs many information from other tools. For instance, PLM systems provide product structure and product variants classification. ERP systems give information about materials and resources used in the past projects, that is necessary to estimate the new product cost. Indeed, vendor catalogues and standard parts databases contain technical and economic information that are useful to build cost models.

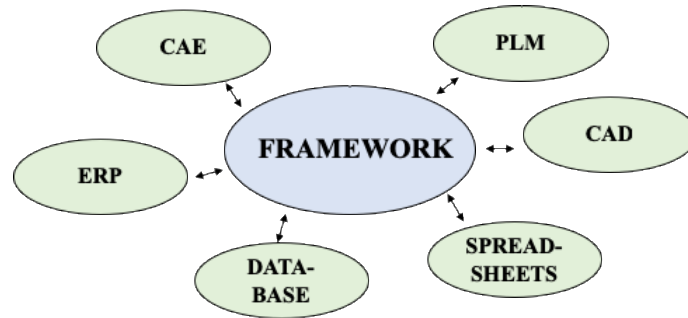

Figure 2 - Framework integration

The framework shares geometrical data with CAD tools, to provide a preliminary 3D layout. Geometrical attributes of the product are used to generate parametric CAD models having a simplified geometry. The simplified 3D layout, which is the output of the conceptual design phase, becomes the starting point of the embodiment design phase. CAE tools receive information from the framework such as product attributes or a preliminary 3D layout while they give results coming from preliminary design optimization and performance verification analysis.

Finally, using API libraries, the integration can be extended to a large variety of customized company tools, such as performance models or simulation software, including existing spreadsheets for component dimensioning and evaluating possible scenarios.

2.2 Support towards a solution

The aim of this section is to describe how the proposed framework can support the user for searching one or more optimal solutions moving from product requirements, tentative product architectures, parts dependencies. Optimization can be based on one or more parameters, e.g. the product cost. Five steps have been identified and show in Figure 3: Instantiation of the DSM; Clustering of the DSM; Partitioning of each cluster; Clusters resolution; Checking for constraints satisfaction and global DSM.

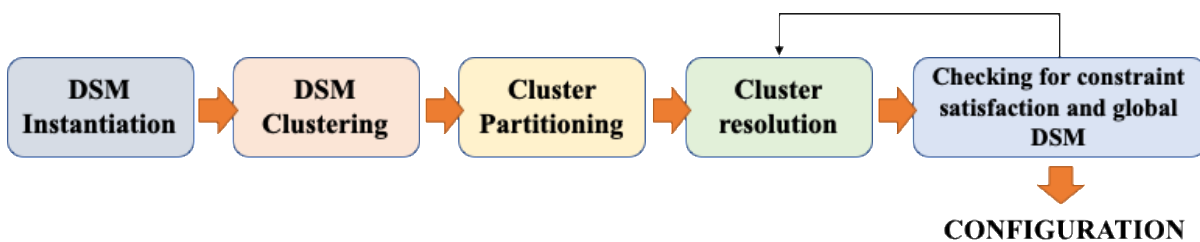

Figure 3 - Method: support towards the solution

A design structure matrix (DSM) provides a simple, compact, and visual representation of a complex decisional system that supports innovative solutions to decomposition and integration problem (Tang *et al.*, 2017). Therefore, a DSM approach has been considered in this paper. In particular, DSM is a square matrix $N \times N$ used to represent the dependencies between N elements of a system. While the instantiation of the parameter-based DSM (step 1) has been thought as automatic, the user defines dependencies in the product architecture. The introduced dependencies generally constitute an intricate and complex network with an elevate degree of coupling between elements. Such complexity can be identified as the main difficulty a designer is facing when trying to figure out a preliminary solution in the early phases.

Clustering the DSM allows to divide the problem into simpler sub-problems of reduced size, which are expected to be much more manageable. This approach is close to the designer perspective, which is used to dealing with problems of limited size. Relationships between the sub-systems as well as input and output data flow are highlighted and monitored.

Clusterization is based on a simulated annealing optimization procedure derived from the one proposed by Thebeau (2001). The advance of such approach lies on the capability of controlling the number, size and composition of the clusters based on custom algorithm parameters and functions.

Once the problem has been divided into sub-problems, i.e. clusters of parameters, each of these can be solved separately. However, clusters maintain couplings between them and should be solved respecting the order in which they appear in the clustered DSM. In order to solve each sub-problem, a partitioning algorithm is applied to each cluster (step 3). The partitioned DSM shows all the product parameters sequenced according to their dependencies, thus it is possible to know when a parameter must be defined in order to proceed with the design process. The partitioning algorithm groups around the diagonal those attributes that need to be defined in the same design step, as highly coupled. Thus, the obtained parameters sequence allows minimizing the iterations during the phase of the determination of the parameters.

In general, the partitioned DSM shows several blocks of coupled parameters, i.e. the parameters that are affected by mutual dependencies. In order to determine these parameters and proceed with the design process, a priori choices are needed. A priori choices are properly characteristics of the design process, e. g. the material selection of a part. Usually assumptions must be verified after an iteration. For example, a constraint on the weight of a part can be verified only after several choices have been made, i.e. the material selection. In order to assess what parameters are the best candidates for a priori choices, an algorithm has been proposed. The algorithm aims to minimize the number of parameters to make assumptions and suggests the parameters to the user. In addition, the method serves to identify the steps in which human choices are needed.

The algorithm tries to remove dependencies from each one of the coupled parameters and, after new partitioning, verifies if triangularization condition is satisfied. Triangularization condition of the DSM means the possibility of determining all the parameters of the block without other parameter assumptions. If only one parameter is not enough to reach the condition, algorithm searches for pairs of parameters, triplets, and so on. Cluster solution, i.e. variable assignment, can be done in different ways, mostly using external tools to be integrated to the framework (e.g., CAD, constraint satisfaction problems (CSP), spreadsheets, CAE) but the overall process is controlled and managed by the proposed framework in a semi-automatic manner. For example, if the problem to be solved consists only of dependencies of math rules type, a CSP solver or an optimization tool can be used for a variable assignment. A CSP can be defined on a finite set of variables whose values belong to the definition of finite domains and a set of constraints. A constraint on a set of variables is a restriction on the values that those variables can take simultaneously. Design process can therefore be considered as a CSP under a set of requirements, assumptions and design limits (Münzer, 2014). On the contrary, if dependencies among the coupled parameters include geometric relations, the problem cannot be solved by a CSP solver and needs the human intervention. In this case, the user should define a plan of experiments to explore the solution space and return the parameter values that the system cannot calculate.

The searching of solutions ends when a valid solution is found, i.e. variable assignment complies with all dependencies within the block. However, it is possible to proceed with the exploration of the solution space in order to find other valid solutions, with the aim of minimizing or maximizing an objective function, e.g. the product cost. In this article, cost optimization has been applied in order to make an offer more competitive, but other parameters can be used for optimization, e.g. the product weight, performance or environmental impact.

Although variable assignment is mostly done manually, the framework monitors the compatibility of each assignment with the set of dependencies. When all the parameters have been assigned and verified, a solution for the entire problem has been found.

2.3 Cost estimation

The cost estimation method is based on past projects data to evaluate the cost of new ETO solutions. Because the costs are attributes of the product, depending on blocks attributes and relationships, they are stored for a possible future reuse. For these reasons, the building of a cost database must precede

the cost estimation activities. The database building consists in the acquisition and classification of past data from previous projects.

Since the aim of the framework is to perform an early cost estimation, a parametric method has been applied for a rapid evaluation along the configuration process. In fact, since a block is described by a set of attributes, the cost of each block can be expressed as a function of its attributes (such as weight, length, area, etc...). These “blocks” can be produced within the company or purchased by a supplier. In the former, cost structure is known, while in the latter, only the total cost is known. For this reason, cost estimation follows two main paths distinguishing purchased materials from produced parts. The proposed cost estimation method for purchased parts is based on regression models, which can be derived by fitting the costs of past purchased codes using one or more relevant parameters (e.g. the power of an electric motor and the output torque for a gearbox). Cost estimation for produced parts are deducted by more complex cost models based on cost structure, allowing a better management of the company resources involved in the manufacturing and life cycle processes.

3 CASE STUDY AND RESULTS

The case study is focused on the design of overhead cranes which are typical engineer to order (ETO) products. Overhead cranes have a good degree of modularity and consist of several sub-systems with different functions. An overhead crane consists of mechanical parts, structural parts and electrical and automation systems. Moreover, some parts are fabricated within the company while others are purchased.

The several specifications and customer requirements make the design of overhead cranes always different. In order to consider all possible combinations of relations and customer requirements, a general functional model has been defined by combining all the customer requirements. In the functional structure the material, energy and signal flows have been reported. Functions have been grouped in order to identify the product modules, which are linked to the physical components, i.e. the blocks of the product architecture. ModuLor (Raffaelli *et al.*, 2011) has been used as a tool for representing the functional and modular structure of an overhead crane. The company knowledge has been ordered and functionally structured, so that it became easier and more efficient to visualize the product architecture.

In the first level of the functional decomposition four different key functions have been identified:

- Hoist the load allows moving the load in the vertical direction, by lifting and lowering it according to the human signal.
- Move the load along the x direction allows moving the load along the transverse direction of the plant
- Move the load along the y direction allows moving the load along the longitudinal direction of the plant
- Transmit the signal allows to transmit the human signal to the crane unit control in order to move the load

As regards the hoist functions, the following building blocks have been identified:

- Drum is responsible for converting the force into a torque
- Drum support allows the transmission of a part of the force to the trolley chassis
- Equalizer system is responsible for transmitting a part of the force to the trolley chassis
- Upper block allows both the transmission of the load force to the hoist driving parts and the transmission of a part of the force to the trolley chassis
- Motor is responsible for converting the electric power into mechanical power, i.e. torque and speed.
- Brake is responsible for dissipating the mechanical energy into thermal energy
- Gearbox allows reducing the needed motor torque
- Drum-Gearbox coupling is responsible for transmitting the torque from the drum to the gearbox
- Inverter allows adjusting the hoist speed at the set speed
- Rope is responsible for transmitting the load force to the hoist driving parts
- Load block allows a safe grip of the load and transmits the load force to the hoist driving parts

The case study concerns a detailed analysis of a representative cluster of the crane hoist system, identifying the functions and the building blocks and then applying the design and the cost estimation

methods above discussed. Once the parameter-based DSM has been instantiated according to the dependencies coming from the product architecture of the crane, the matrix has been reordered by means of clustering algorithms, in order to divide the problem into more sub-problems of reduced size. In fact, because of the highly-coupled problem nature, a partitioning of the entire DSM would lead to just one big cluster. The resulting clustered DSM in Figure 4 shows several blocks of highly coupled parameters, but the dependencies among clusters are much lower. Each matrix cluster has been treated as an individual problem and has been solved independently from the others.

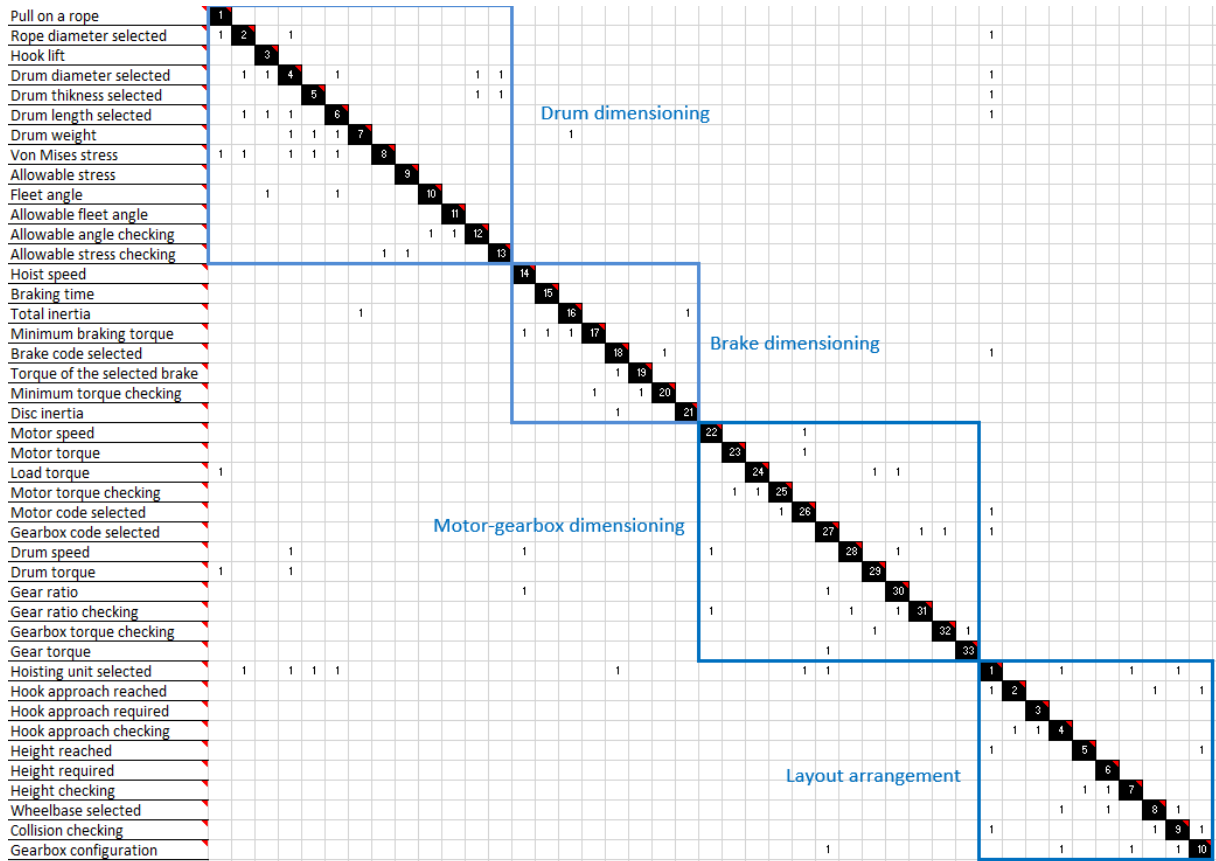

Figure 4 - Clustered DSM

The example regards the resolution of a cluster of 12 coupled parameters resulting from the clustered DSM and is related to the dimensioning of the drum, which is a part of the rope winding module (Figure 5).

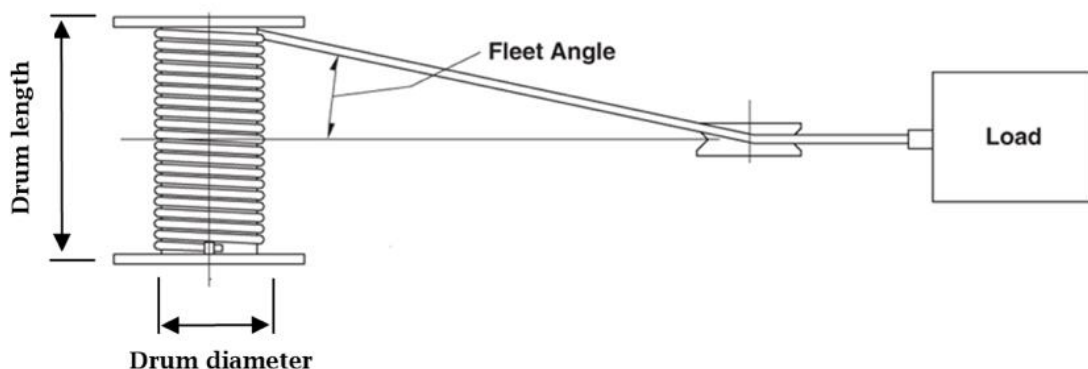

Figure 5 - The hoisting drum

Regarding the related DMS, the parameters of the block include dimensions, weight and stress of the drum due to the pull on the rope. Moreover, they also comprise relations with other clusters, such as the crane requirements: i.e. the rope diameter must ensure the support of the maximum load, and the

drum length must be enough to ensure the hook lift. Checking parameters (True/False values) include the verification of the following inequality constraint:

$$\text{equivalent drum stress} \leq \text{allowable stress} \quad (1)$$

$$\text{fleet angle} \leq \text{allowable fleet angle} \quad (2)$$

The stress state is calculated according to normative and considering the fleet angle. The partitioning of the coupled block has led to the DSM in Figure 4 (a). On the other hand, The Figure 6(b) shows the DSM partitioned after removing dependencies by this specific pair of parameters. Removing the dependencies only for one parameter at a time, the condition of triangularization is not yet satisfied. Instead, searching for pairs of parameters, several alternatives have been found. Discarding the pairs containing verification parameters, the solving iteration has given the Drum Diameter and the Drum Thickness parameters as a possible solution for a priori choices.

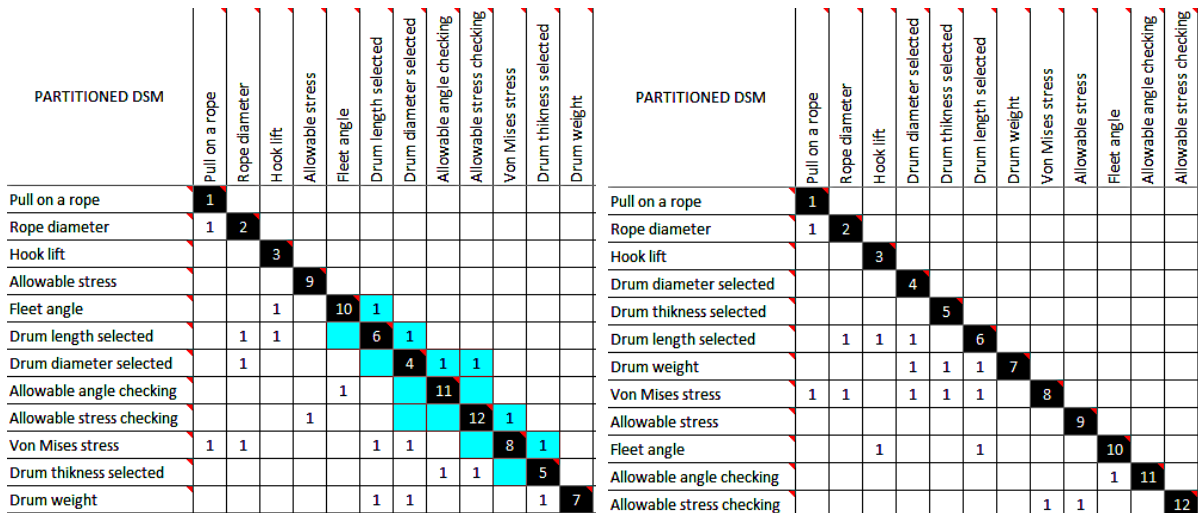

Figure 6 - Partitioned DSM of the hoist drum before (a) and after (b) tearing

In order to solve the problem in a manual manner, i.e. without a CSP solver, a DOE plan has been assigned, which provides the drum diameter and thickness variation in 5 levels. Consequently, the DOE plan consists of $5^2 = 25$ experiments. A company spreadsheet has been used to calculate the other parameters of the DSM and check the dependencies.

Since (3) must be always verified, where k is a coefficient given in the FEM standards which depends on the hoist FEM class, the minimum drum diameter follows the rope diameter choice. A rope diameter of 24 mm descends from the pull on a rope value. Because k is 20 according to M6 FEM class, the drum diameter must be at least 480 mm.

$$\text{Drum diameter} \geq k * \text{Rope diameter} \quad (3)$$

By choosing an arbitrary maximum for the drum diameter of 800 mm and a range for the drum thickness from 30 to 70, the DOE plan, which reports also the results for the other parameters of the cluster, is shown in Table 6. Allowable fleet angle is 2° and allowable stress is 110 MPa according to the FEM standards, hook lift is 16 m by customer specifications. Although the weight can be retrieved from the CAD environment, it can be also calculated by Eq. (4), where D, t and L are respectively the drum diameter, thickness and length and ρ is the density of the drum material.

$$\text{weight} = \rho \pi L \frac{D^2 - (D-2t)^2}{4} \quad (4)$$

Table 1 – DOE plan for drum dimensioning

Nr	Drum diameter	Drum thickness	Drum length	Drum weight	VM stress	Fleet angle	Angle checking	Stress checking
1	480	30	2860	952	197	2,7	False	False
2	480	40	2860	1241	135	2,7	False	False
3	480	50	2860	1516	104	2,7	False	False
4	480	60	2860	1777	84	2,7	False	True

5	480	70	2860	2024	71	2,7	False	True
6	560	30	2530	992	190	2,3	False	False
7	560	40	2530	1298	130	2,3	False	False
8	560	50	2530	1591	99	2,3	False	True
9	560	60	2530	1872	80	2,3	False	True
10	560	70	2530	2140	67	2,3	False	True
11	640	30	2320	1047	186	2,1	False	False
12	640	40	2320	1373	127	2,1	False	False
13	640	50	2320	1688	96	2,1	False	True
14	640	60	2320	1991	78	2,1	False	True
15	640	70	2320	2283	65	2,1	False	True
16	720	30	2100	1072	183	1,8	True	False
17	720	40	2100	1409	125	1,8	True	False
18	720	50	2100	1735	95	1,8	True	True
19	720	60	2100	2051	76	1,8	True	True
20	720	70	2100	2356	64	1,8	True	True
21	800	30	1940	1105	181	1,6	True	False
22	800	40	1940	1454	123	1,6	True	False
23	800	50	1940	1794	94	1,6	True	True
24	800	60	1940	2124	75	1,6	True	True
25	800	70	1940	2445	63	1,6	True	True

Table 1 shows in the rows highlighted in green the six valid solutions that have been found in this test case. Due to the presence of several solutions that satisfy the dependencies of the DSM matrix, an objective function to decide the best alternative has been defined (5). This condition allows to select one of the best alternatives in terms of cost among the space of solutions, because it was found that the drum cost is approximately dependent from the weight. According to the objective function, experiment 8 is the best alternative. However, a new DOE plan can be performed for further investigations within the solutions domain that has been found, with the aim to find other valid solutions and eventually a new optimum.

$$f_{obj} = \text{Min}(\text{Weight}) \quad (5)$$

4 CONCLUSIONS AND DISCUSSION

This paper confirms the necessity to apply knowledge-based methodologies in the design of complex ETO products. A methodology has been proposed to face a complex problem analysing different sub-problems reduced in size in order to achieve priori choices during the offer stage. This methodology can support the user during the conceptual phase towards a solution of the design problem considering life cycle parameters. The cost estimation is parameter-based and therefore it is related to the attributes that have been calculated in the conceptual design stage. The application of this method has shown a good estimation of the final cost.

The application is focused on ETO products which can also include non-mechanical systems, i.e. electrical, hydraulic, electronic, software and automation. Unlike make to order or assemble to order products, ETO products require a considerable effort during the configuration stage, which must precede the cost estimation.

The preliminary results have shown that the methodologies give a valid support to the offer stage of ETO products such as overhead cranes. However, the final tool implementation is still ongoing. Future research can be oriented to include solver tools for variable assignment within the framework that allow to find design solutions in an automatic manner. The final goal is let the users introduce rules and constraints in an unstructured manner, and the system to autonomously manage the dependencies and seek for the solution without predefined strategies. This would also provide flexibility in the IT tool, easy updating of the knowledge base and, then, its maintenance.

REFERENCES

Anon (2007), "Factors that influence Manufacturing Costs and Procedures for Cost Reduction", *Cost-Efficient Design*, pp.143–384. Available at: http://dx.doi.org/10.1007/978-3-540-34648-7_7.

- Anon (2016), “Artificial Intelligence Techniques”. *Advanced Solutions in Power Systems: HVDC, FACTS, and Artificial Intelligence*, pp.719–720. Available at: <http://dx.doi.org/10.1002/9781119175391.part3>.
- Cicconi, P. et al. (2018), “A model-based simulation approach to support the product configuration and optimization of gas turbine ducts”, *Computer-Aided Design and Applications*, Vol. 15 No. 6, pp. 807–818. Available at: <http://dx.doi.org/10.1080/16864360.2018.1462564>.
- Höltkä-Otto, K. and Otto, K. (2006), “Platform Concept Evaluation”, *Product Platform and Product Family Design*, pp. 49–72. Available at: http://dx.doi.org/10.1007/0-387-29197-0_4.
- Kristianto, Y., Helo, P. and Jiao, R.J. (2015), “A system level product configurator for engineer-to-order supply chains”, *Computers in Industry*, Vol. 72, pp. 82–91. Available at: <http://dx.doi.org/10.1016/j.compind.2015.04.004>.
- La Rocca, G. (2012), “Knowledge based engineering: Between AI and CAD. Review of a language based technology to support engineering design”, *Advanced Engineering Informatics*, Vol. 26 No. 2, pp. 159–179. Available at: <http://dx.doi.org/10.1016/j.aei.2012.02.002>.
- Lewis, G. (2015), “Product Design for Manufacturing and Assembly. Mechanical Engineers”, *Handbook*, pp. 1–19. Available at: <http://dx.doi.org/10.1002/9781118985960.meh202>.
- McMahon, C., Lowe, A. & Culley, S., 2004. Knowledge management in engineering design: personalization and codification”, *Journal of Engineering Design*, Vol. 15 No 4, pp. 307–325. Available at: <http://dx.doi.org/10.1080/09544820410001697154>.
- Münzer, C. H. (2014). “Constraint-Based Methods for Automated Computational Design Synthesis of Solution Spaces”, Ph.D. Thesis, Technische Universität München, Zurich.
- Opiyo, E.Z. (2017), “A feature-based approach to conceptualisation, upfront modelling, and planning for the future of complex systems”, *International Journal of Information Technology and Management*, Vol. 16 No. 1, p. 91. Available at: <http://dx.doi.org/10.1504/ijitm.2017.10001055>.
- Otto, K. et al. (2016), “Global Views on Modular Design Research: Linking Alternative Methods to Support Modular Product Family Concept Development”, *Journal of Mechanical Design*, Vol. 138 No. 7, p. 071101. Available at: <http://dx.doi.org/10.1115/1.4033654>.
- Pahl, G. et al. (2007), “Engineering Design”. Available at: <http://dx.doi.org/10.1007/978-1-84628-319-2>.
- Raffaelli, R., Mengoni, M. and Germani, M. (2011), “An Early-Stage Tool to Evaluate the Product Redesign Impact”, Vol 5: *37th Design Automation Conference, Parts A and B*. Available at: <http://dx.doi.org/10.1115/detc2011-47625>.
- Raffaelli, R., Mengoni, M. & Germani, M. (2013), “Improving the link between computer-assisted design and configuration tools for the design of mechanical products”, *Artificial Intelligence for Engineering Design, Analysis and Manufacturing*, Vol. 27 No. 01, pp. 51–64. Available at: <http://dx.doi.org/10.1017/s0890060412000388>.
- Ripperda, S. and Krause, D. (2017), “Cost Effects of Modular Product Family Structures: Methods and Quantification of Impacts to Support Decision Making”, *Journal of Mechanical Design*, Vol. 139 No. 2, p. 021103. Available at: <http://dx.doi.org/10.1115/1.4035430>.
- Simpson, T.W. (2017), “Product Family and Product Platform Benchmarking With Commonality and Variety Indices”, Vol. 2B: *43rd Design Automation Conference*. Available at: <http://dx.doi.org/10.1115/detc2017-67500>.
- Tang, D., Yin, L. and Ullah, I. (2017), “Product Design as Integration of Axiomatic Design and Design Structure Matrix”, *Matrix-based Product Design and Change Management*, pp. 1–20. Available at: http://dx.doi.org/10.1007/978-981-10-5077-0_1.
- Thebeau, R. E. (2001), “Knowledge management of system interface and interactions for product development processes”, PhD Thesis, *Massachusetts Institute of Technology*.
- Verhagen, W.J.C. et al. (2012), “A critical review of Knowledge-Based Engineering: An identification of research challenges”, *Advanced Engineering Informatics*, Vol. 26 No. 1, pp. 5–15. Available at: <http://dx.doi.org/10.1016/j.aei.2011.06.004>.
- Wang, L. et al. (2002), “Collaborative conceptual design—state of the art and future trends”, *Computer-Aided Design*, Vol. 34 No. 13, pp. 981–996. Available at: [http://dx.doi.org/10.1016/s0010-4485\(01\)00157-9](http://dx.doi.org/10.1016/s0010-4485(01)00157-9).
- Windheim, M., Greve, E. and Krause, D. (2017), “Decisive economies and opportunity cost of modular product structure alternatives: An empirical case study”, *2017 IEEE International Conference on Industrial Engineering and Engineering Management (IEEM)*. Available at: <http://dx.doi.org/10.1109/ieem.2017.8290170>.
- Zhu, Z., La Rocca, G. and van Tooren, M.J.L. (2017), “A methodology to enable automatic 3D routing of aircraft Electrical Wiring Interconnection System”, *CEAS Aeronautical Journal*, Vol. 8 No. 2, pp. 287–302. Available at: <http://dx.doi.org/10.1007/s13272-017-0238-3>.