

PAPER • OPEN ACCESS

Ventilated pitched roof with forced ventilation and flow homogenizer device: testing and performance assessment

To cite this article: C Ferrari and A Muscio 2019 *J. Phys.: Conf. Ser.* **1224** 012027

View the [article online](#) for updates and enhancements.



IOP | ebooks™

Bringing together innovative digital publishing with leading authors from the global scientific community.

Start exploring the collection—download the first chapter of every title for free.

Ventilated pitched roof with forced ventilation and flow homogenizer device: testing and performance assessment

C Ferrari, A Muscio

EELab – Dip. di Ingegneria “Enzo Ferrari” – Univ. di Modena e Reggio E., Italy

Corresponding author: alberto.muscio@unimore.it

Abstract. Ventilated tile roofs are common objects in the construction sector of Italy. A preferred type is characterized by a ventilated air space between the upper tile layer and the roof structure below. The air enters through openings at the gutters level, flows up below sheathing in the air space along the pitch and is finally discharged through openings along the ridge. This setup, which leaves the room below the roof sealed and habitable, allows removing the heat brought by the absorbed solar radiation thanks to the flow that is established by natural ventilation in the air space. However, its actual performance is often weak and also unpredictable due to continuously changing buoyancy forces. Nonetheless, a permanent and adequate flow can be ensured even through a relatively thin air space and for whichever irradiance and wind conditions by forced ventilation: a properly designed fan can provide the desired flow rate by extracting the air after this is collected along the ridge by a manifold. A thorough design and manufacturing of the manifold is needed, however, to avoid a highly inhomogeneous flow, which would follow the easiest path and leave most of the pitch practically unventilated. As an alternative, a throttling shutter parallel to the ridge has been proposed to progressively choke the flow entering the manifold through parallel climbing ducts as the fan is approached, possibly allowing onsite adjustment after installation. In this work the solution, developed by means of a small scale test bed, is illustrated in details and some methods to assess the performance are presented.

1. Introduction

Ventilated tile roofs are common objects in the construction sector of Italy. A common type seems that characterized by a ventilated air space between the upper tile layer above, which rests on a waterproofing membrane and a wooden slab, and the lower remaining layers of the roof structure. The air enters through openings at the gutters level, flows up along the pitch in the airspace below sheathing and is finally discharged through openings along the ridge (Figure 1). This setup, which leaves the room below the roof sealed and habitable, allows removing heat brought by the absorbed



Content from this work may be used under the terms of the [Creative Commons Attribution 3.0 licence](https://creativecommons.org/licenses/by/3.0/). Any further distribution of this work must maintain attribution to the author(s) and the title of the work, journal citation and DOI.

solar radiation thanks to the natural airflow that is established in the ventilated air space. Moreover, moisture that may condense in the roof can be evaporated and removed by the flowing air. An airspace as thick as 7-10 cm is needed, however, to allow an adequate airflow, but this is seldom the case. Generally speaking, buoyancy forces that induce the airflow depend on warming up of the flowing air as resulting from the complex and continuously changing thermal balance of solar absorption and other heat transfer processes, and such forces can also be countered by wind counter-pressure, so that the actual performance of such type of ventilated roof is often unpredictable.

An extensive analysis of parameters affecting the performance of ventilated roofs can be found in [1-5] and, with regard also to the roof dynamic behavior, in [6-9], considering both above and below sheathing ventilation. Studies have been aimed to improve natural flow in pitched roofs, for example by using novel tile geometries [10], proper design of the insulation layer [11], radiant barrier inside the gap [12], thermal breaker to prevents heat conduction through the air space [13], combination with cool roofs [9,14]. See also [15,16] for reviews of double skin building elements.

Forced ventilation can ensure an adequate airflow for whichever irradiance and wind conditions and even through a relatively thin air space: a properly designed fan can provide the desired flow rate by extracting the air after this collected along the ridge by a manifold (Figures 2-3). Compared to a conventional ventilated roof with natural circulation (Figure 1), the main advantage of the investigated approach based on forced circulation consists of the accurate control of the airflow, which can be given a flow rate always adequate and independent of the surrounding environmental conditions. Moreover, the airflow can be easily modulated by controlling the fan speed and possibly suppressed when it is not desired, for example at night or during the winter season. Electrical energy could also be supplied by a small photovoltaic panel installed on the roof, which will ensure the maximum power under the maximum solar irradiance (*i.e.* when ventilation is mostly needed) and for which an inverter may not be needed if a DC fan is used. A solar chimney like in [12] or a solar turbine could also be used.

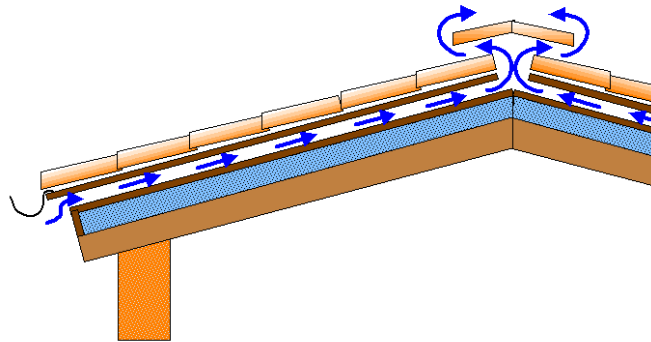

Figure 1. Pitched roof with natural ventilation: cross section and ridge outlet.

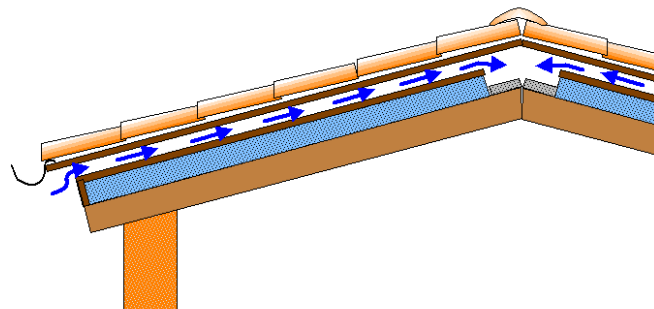

Figure 2. Pitched roof with forced ventilation: cross section with climbing ventilation ducts and ridge manifold.

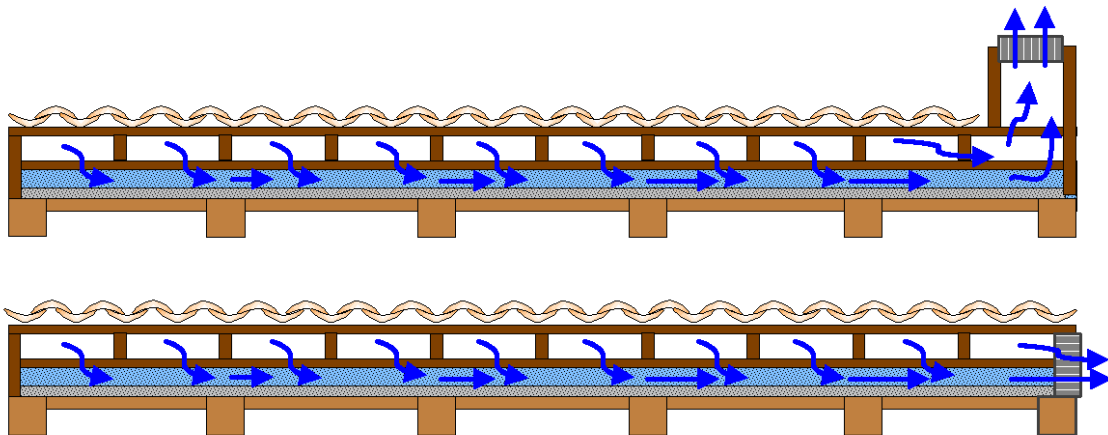

Figure 3. Ridge manifold for a pitched roof with forced ventilation: cross section along the duct outlets, layouts with chimney (top) or side (bottom) extraction fan.

A thorough design and manufacturing is needed for the ventilation system and, above all, for the manifold that collects the air along the ridge and passes it to the fan to avoid a strong non-homogeneity of the airflow, which would follow the easiest path and leave most of the pitch practically unventilated. Therefore, a throttling shutter parallel to the ridge has been proposed [17-19] to progressively choke the flow through the outlets of the parallel climbing ducts as the fan is approached (Figure 4). This approach to forced ventilation of pitched roofs, which can allow onsite adjustment after installation and, in principle, can be applied also with flat horizontal roofs [12], was already experimented through a small scale test bed, with positive results [17-19]. In this work, the concept is illustrated in details and the experimental procedure to assess the airflow distribution and adjust the throttling shutters is tested by the small scale test bed.

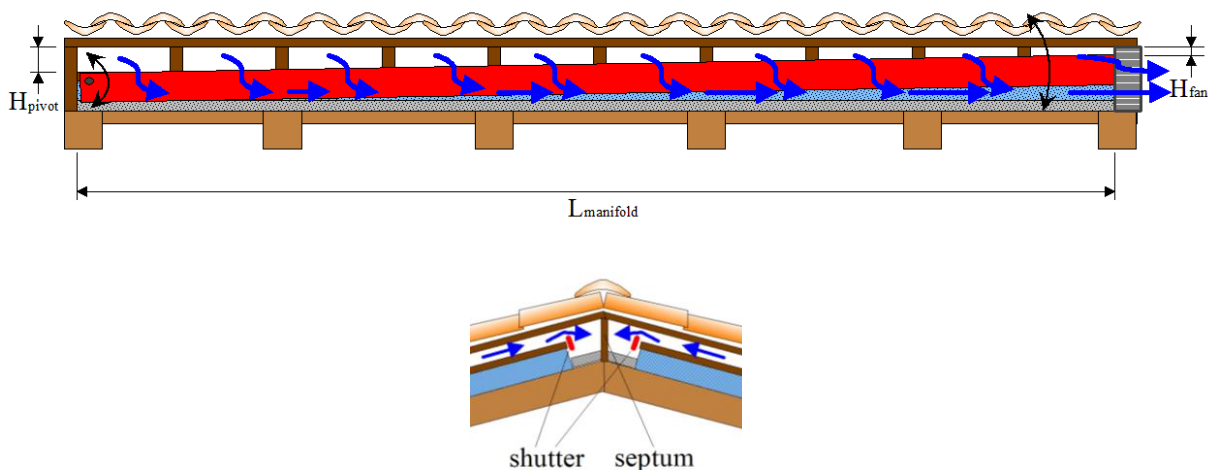

Figure 4. Ridge manifold for pitched roof with forced ventilation: cross section along the duct outlets and pivoted throttling shutters (in red).

2. Pitched roof with forced ventilation

The proposed layout of pitched roof with forced ventilation has been sketched in Figures 2-4, where a single pitch is considered for sake of simplicity. The air is sucked through openings at the gutters level, which can be made according to current practice for ventilated roofs with natural circulation; thereafter it flows along the roof pitch through a series of side-by-side ascending ducts. These ducts are built below sheathing, between the upper wooden slab that supports the tile mantle and a lower

wooden slab that protects the thermal insulation layer below, the latter represented in Figures 2-4 by the pale blue layer. The side walls of the climbing ducts can be made by parallel joists that connect the upper and lower slabs; this is needed to make the flow in each duct independent of that in the others. The air flowing in the ducts subtracts and carries away heat from the tile mantle and the wooden slab above, thus limiting overheating when the roof is subjected to direct insolation. Rather than being directly discharged into the atmosphere, as it occurs in naturally ventilated roofs (Figure 1), the air is collected at the outlets of the ducts by a manifold that follows the ridge and eventually discharges the warm air into the external environment thanks to an extraction fan (Figures 2-3). The fan can be installed in a chimney close to the ridge or in an outlet hole at one end of the ridge, in the side wall, and it may serve parallel manifolds for opposite pitches of a two-pitched roof. In this case, a separation septum may be appropriate between the parallel manifolds (Figure 4) to avoid wind-induced cross air circulation. The fan can also be installed in a chimney at the midpoint of the ridge and serve symmetrical manifolds, to limit the manifold length. In order to allow a continuous tile mantle from the gutters to the ridge, the manifold can be incorporated in the roof thickness at the expense of the insulation layer, for which a lower thickness of a high performance yet expensive materials such as aerogel (represented in grey in Figures 2-4) could be afforded in view of the low quantity of material to be used.

A main issue of a forced ventilation system as outlined above is to obtain a homogeneous distribution of air: the airflow would generally follow the easiest path, which is that through the ducts closest to the fan, and it would thus leave the farthest ducts practically unventilated. Of course, the situation would be even worse without joists that divide the ventilated air space in parallel ducts. Such issue can be avoided by a proper design and manufacturing of the manifold that collects the air along the ridge and brings it to the fan, for example using a continuously varying cross-section of the manifold itself rather than a homogeneous one (as common for manifolds of parallel tube heat exchangers). This may be unpractical, however, since it would require a targeted design for each roof, made by a skilled designer with proper design tools. Moreover, a very accurate manufacturing would be needed for the manifold and the whole ventilation system, something that is not easy to ensure in the construction sector. An alternative and more viable solution can be obtained through a simple and effective regulation mechanism, which can be adjusted after the roof has been built on the basis of simple thermal and/or fluid flow measurements. The mechanism consists of a throttling shutter (showed with red color in Figure 4) that follows the ridge line and progressively chokes the flow through the outlets of the ducts as the fan is approached. It is pivoted at one end of the manifold and adjusted up or down at the other end, with a chopping motion, in order to reduce the outlet height from a maximum value H_{pivot} close to the pivot down to a minimum value H_{fan} at the end of the manifold length L_{manifold} .

The verification of the airflow distribution can be carried out by infrared thermography, measuring the temperature distribution of the covering surface (tiles, shingles, etc.) when this is subjected to solar radiation [17-19]: areas affected by inadequate ventilation will tend to overheat, while areas affected by an excessive flow rate will show a temperature closer to that of the cooling air. The throttling shutter can thus be adjusted, and the outlet cross section of the ducts increasingly reduced close to the fan, until an adequate homogeneousness of the surface temperature is achieved. However, time could be needed to let the temperature to reach a new steady state distribution after each adjustment, moreover changing solar irradiance may disturb the process.

An alternative and much less time consuming approach to verify the flow distribution consists of measuring the air velocity along the gutters, at the center of the duct inlets, by means of an anemometer. A hot wire or hot sphere anemometer could be used to have a small probe size and not interfere significantly with the airflow, which would also reach a new steady state distribution very quickly after each adjustment.

3. Adjustment of flow distribution

The flow distribution was tested on a small scale test bench representing a single pitch of a two-pitched roof with about 1:10 scale. The length of the manifold L_{manifold} is 958 mm, the length of the pitch and the climbing ducts is 520 mm, the height of the duct cross section is 11 mm, the width is 40 mm gross and 35 mm net of spacer joists. A DC axial fan with 60 mm x 60 mm size is installed in a vertical chimney and extracts the air at one end of the manifold. A flat rod pivoted at the opposite end is used as a throttling device, with the pivot positioned in order to leave the local height H_{pivot} of the duct cross-section at the maximum value of 11 mm. The rod movement allows to change the height H_{fan} of the duct cross-section below the fan from the maximum value of 11 mm, equivalent to absence of the throttling device, down to almost 0. The air velocity is measured at each duct inlet by means of a Testo hot bulb thermal anemometer integrated in a flow, temperature and humidity probe, connected to Testo 400 portable data acquisition device with accuracy $\pm(0.03 \text{ m/s} + 5\%$ of the measured value).

Some laboratory experiments aimed at validating further the effectiveness of the throttling device and verifying the usefulness of the approach to assess and optimize the airflow distribution were carried out by means of the above described test bench. More specifically, the air velocity distribution was thus determined for different settings of the throttling device, as shown in Figure 5.

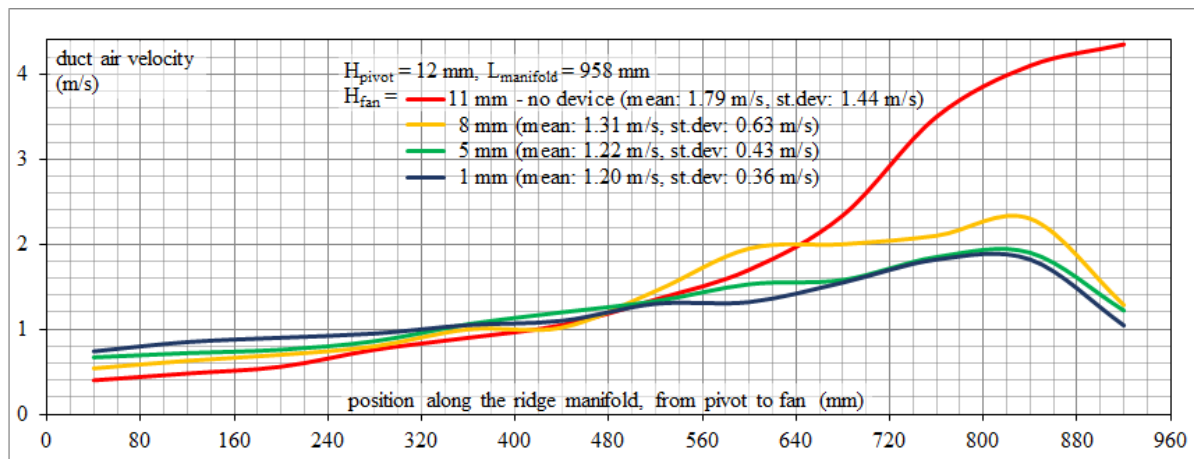

Figure 5. Air velocity distribution for different settings of the throttling device, measured at the duct inlets from pivot (left side) to fan (right side).

As expected, without the throttling device the distribution is completely non-homogeneous, with most of the air flowing in the ducts close to the fan, and a very low air velocity occurring on the opposite side. Lowering the cross-section height below the fan, H_{fan} , progressively improves the homogeneity of the airflow, as shown by the relatively flat distribution of air velocity and the lower value of its standard deviation shown in Figure 4, with a relatively low penalization in terms of average velocity and, consequently, of total flow rate. The air velocity in the ducts farthest from the fan is almost doubled. At one point, decreasing further H_{fan} does not seem to yield significant improvements.

4. Assessment of performance of the ventilated roof

The efficiency of roof ventilation can be assessed in different ways. A parameter that will be analysed in future work is the efficiency of removal of absorbed solar heat, that is the ratio η_A (%) of the heat rate removed by the airflow and the heat rate brought by the absorbed solar radiation:

$$\eta_A = \frac{\dot{Q}_{\text{removed}}}{\dot{Q}_{\text{absorbed}}} \quad (1)$$

The heat rate removed by the airflow, \dot{Q}_{removed} (W), can be calculated by the relationship:

$$\dot{Q}_{\text{removed}} = \rho_{\text{out}} \cdot c_{p,\text{out}} \cdot w_{\text{out}} \cdot A_{\text{out}} \cdot (T_{\text{out}} - T_e) \quad (2)$$

where

- ρ_{out} density of the extracted air (kg/m^3)
- $c_{p,\text{out}}$ specific heat at constant pressure of the extracted air ($\text{J}/(\text{kg}\cdot^\circ\text{C})$)
- w_{out} average velocity of the extracted air (m/s)
- A_{out} outlet cross section area (m^2)
- T_{out} temperature of the extracted air ($^\circ\text{C}$)
- $T_e = T_{\text{in}}$ temperature of the external ambient air/entering air ($^\circ\text{C}$)

The heat rate brought by the absorbed solar radiation, $\dot{Q}_{\text{absorbed}}$ (W), can be calculated as follows:

$$\dot{Q}_{\text{absorbed}} = A_e \cdot \alpha \cdot I_{\text{sol}} \quad (3)$$

where

- A_e external/insolated surface area of the roof pitch (m^2)
- α solar absorptance ($0 < \alpha < 1$)
- I_{sol} solar irradiance (W/m^2)

Some outdoor experiments were carried out by the small scale test bed to verify the approach. A constant volume flow rate of $3.6 \text{ m}^3/\text{h}$ was measured by a fan anemometer with probe installed in the chimney duct, downstream of the extraction fan. The temperatures of the ambient air and the extracted air were measured by type T thermocouples with 1 mm shielded probe, connected to a PicoLog TC-08 USB data acquisition system with cold junction compensation. The solar irradiance was measured by a Delta Ohm pyranometer model LP 471-PYRA-02-10 operating in the $305\div 2800 \text{ nm}$ range, with probe placed coplanar with the insolated surface. A solar absorptance $\alpha = 0.69 \pm 0.05$ was measured by a solar reflectometer D&S SR1 v6 according to the ASTM C1549 test method [20] with beam normal solar spectrum as reported in ASTM E891 [21]. Sample data for this analysis approach are shown in Figure 6.

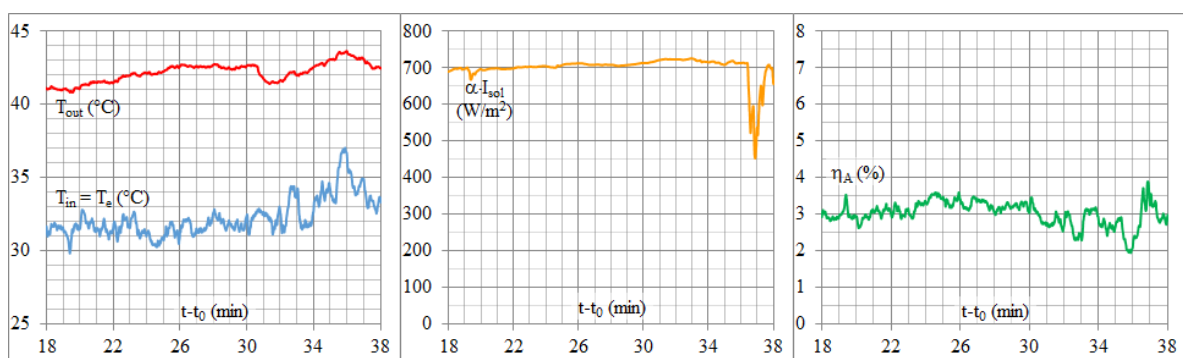

Figure 6. Inlet/external temperatures, $T_{\text{in}}=T_e$, and outlet temperatures, T_{out} (left); absorbed solar irradiance, $\alpha \cdot I_{\text{sol}}$ (middle); efficiency of removal of the absorbed solar heat, η_A (right).

An alternative and more used approach, analogous to that considered in [1], is to evaluate the reduction of transmitted heat rate η_B (%) allowed by roof ventilation with respect to absence of ventilation:

$$\eta_B = \frac{\dot{Q}_{\text{removed}}}{\dot{Q}_{\text{transmitted}}} \quad (4)$$

For a lightweight roof structure with negligible inertia and thermal transmittance U ($\text{W}/(\text{m}^2\text{°C})$), the transmitted heat rate without ventilation can be estimated as

$$\dot{Q}_{\text{transmitted}} = U \cdot A_e \cdot (T_e + R_{se} \cdot \alpha \cdot I_{\text{sol}} - T_i) \quad (5)$$

where

R_{se} external surface resistance ($\text{m}^2\text{°C}/\text{W}$)

T_i indoor temperature (e.g. 27°C in summer)

R_{se} can be evaluated from the wind velocity v_{wind} (m/s) and the mean external temperature T_{me} (°C), i.e. the mean of external ambient temperature and external surface temperature. With typical summer values of T_{me} between 35°C and 45°C , the following semi-empirical formula can be obtained [22]:

$$R_{se} \approx 1/(10 + 4 \cdot v_{\text{wind}}) \quad (6)$$

In the considered test case, in which $T_e = T_i$, $v_{\text{wind}} \approx 1.5$ m/s, and $U \approx 1/(2 \cdot R_{se})$, the percent reduction of transmitted heat rate η_B is shown in Fig. 7.

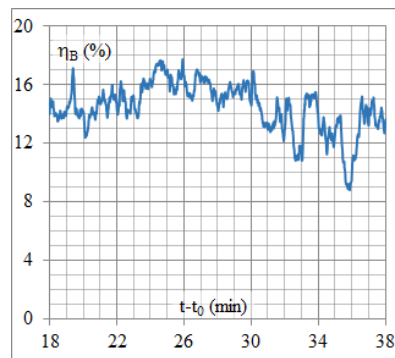

Figure 7. Percent reduction of transmitted heat allowed by roof ventilation with respect to absence of ventilation.

Generally speaking, rather than instantaneous values, averages over a given time period could be considered to take care of fluctuations of ambient conditions coupled with the thermal inertia of the roof layers, whatever low this is.

It must be underlined that the results obtained through the small scale bed are only qualitatively representative of a full scale roof system since some fluid dynamic phenomena don't linearly depend on size, yet they clearly show the effectiveness of the proposed throttling device. On the other hand, the experimental approach can be easily scaled up to a full size roof system.

5. Conclusive remarks

A novel approach to roof ventilation that relies upon forced flow rather than buoyancy force was investigated. In fact, exploiting a fan makes the airflow independent of the randomly varying environmental conditions and may limit the efforts to design and build the roof system. The considered layout is partially based on components of conventional naturally ventilated roofs (gutter inlets, ventilation cavity) and it may even permit to simplify the remaining components, consisting of a simple extraction manifold with fan instead of extraction outlets along the ridge, and also allow a continuous tile cover from gutters to ridge. Complexity of roof design and building is limited by an original regulation device, which improves flow homogeneousness in the ventilated air space and can

be adjusted on site by simple thermographic or fluid velocity measurements. The effectiveness of the device was demonstrated by small scale experiments.

The fan extracting the airflow from the roof air space requires electrical energy, nevertheless a passive scheme can be obtained by adopting a small PV system installed on the roof, or a solar chimney, or a solar turbine. Moreover, the air ventilation can be easily reduced or even stopped when it is not desired, for example during the nighttime to allow radiative cooling of the tile mantle, or in winter to limit heat loss.

Approaches to assess the performance of the ventilation system are enabled by its conceptual simplicity and can be based on simple temperature and fluid velocity measurements. Such approaches were eventually tested on the small scale test bed, resulting easy to implement. In order to scale up to a full scale roof system, the test bed will be exploited to validate a CFD model, which will then be adapted to full scale simulation.

Acknowledgements

The authors wish to thank student Giorgia Paltrinieri for her support work.

References

- [1] Ciampi M, Leccese F, Tuoni G 2005 *Sol. Energy* **79** 183
- [2] D'Orazio M, Di Perna C, Principi P, Stazi A 2008 *Energ. Buildings* **40** 911
- [3] D'Orazio M, Di Perna C, Di Giuseppe E 2010 *Energ. Buildings* **42** 1619
- [4] Susanti L, Homma H, Matsumoto H 2011 *Energ. Buildings* **42** 1337
- [5] Tong S, Li H 2014 *Build. Environ.* **81** 296
- [6] Li D, Zheng Y, Liu C, Qi H, Liu X 2016 *Sust. Cities Soc.* **22** 8
- [7] Villi G, Pasut W, De Carli M 2009 *Build. Simul.* **2** 215
- [8] Zingre KT, Yang E-H, Wan MP 2017 *Energy* **133** 900
- [9] Zingre KT, Wan MP, Wong KW, Toh WBT, Lee IYL 2015 *Energy* **82** 813
- [10] Bottarelli M, Bortoloni M, Zannoni G, Allen R, Cherry N 2017 *Energy* **137** 391
- [11] Gagliano A, Patania F, Nocera F, Ferlito A, Galesi A 2012 *Energ. Buildings* **49** 611
- [12] Dimoudi A, Androusoopoulos A, Lycoudis S 2006 *Energ. Buildings* **38** 610
- [13] Lee S, Park SH, Yeo MS, Kim KW 2009 *Build. Environ.* **44** 1431
- [14] Di Giuseppe E, Sabbatini S, Cozzolino N, Stipa P, D'Orazio M 2018 *J. Bldg. Phys.*, in press
- [15] Ascione F 2017 *Solar Energy* **154** 34
- [16] Zhang T, Tan Y, Yang H, Zhang X 2016 *Applied Energy* **165** 707
- [17] Tarozzi L, Caffagni E, Muscio A 2007 *Proc. 9th AITA* 373
- [18] Caffagni E, Libbra A, Muscio A, Tarozzi L 2008 *Proc. Terza giornata di studio UIT su "Tecniche ottiche e termografiche in termofluidodinamica"*
- [19] Caffagni E, Libbra A, Muscio A, Tarozzi L 2018 *Adv. Civil Engineering Technology* **1**
- [20] ASTM 2016 *ASTM C1549-16*
- [21] ASTM 1995 *E901-82(1995)e1*
- [22] CEN 2018 *EN ISO 6946:18*