

Article

# The Systematic Design of Industrial Products through Design Archetypes: An Application on Mechanical Transmissions

Alberto Vergnano, Francesco Gherardini \*  and Francesco Leali

Department of Engineering “Enzo Ferrari”, University of Modena and Reggio Emilia, Via Vivarelli 10, 41125 Modena, Italy; alberto.vergnano@unimore.it (A.V.); francesco.leali@unimore.it (F.L.)

\* Correspondence: francesco.gherardini@unimore.it

Received: 20 December 2019; Accepted: 16 March 2020; Published: 27 March 2020



**Featured Application:** This paper presents how to develop a top-down design tool, namely a design archetype that stores knowledge and supports a designer in the selection and dimensions of the most suitable working principles to address the requirements of a project. Thanks to the integration between a knowledge-based approach and parametric three-dimensional (3D) computer-aided design (CAD) modeling, the design tool automatically generates CAD models of the mechanical components and the final assembly. The usability of the design tool is improved by a Graphical User Interface which is able to support designers during input data entry and output data management.

**Abstract:** Engineering design is a knowledge intensive activity for both new and mature technical systems, such as mechanical transmissions. However, design knowledge is often transferred with conservative and unstructured approaches, although knowledge management would be of the utmost importance for modern industries. In this work, we introduce a design tool, called design archetype, for collecting and managing knowledge in systematic design processes. The design archetype addresses input design requirements for different design concepts, therefore, improving awareness of the design process by interactively modifying the design solution due to different input requirements. Finally, the design archetype updates the parameters of a first embodiment computer-aided design model of the concept. A method for the development of design archetypes is presented and applied to two case studies of mechanical transmission subassemblies. The results demonstrate the effectiveness of a systematic design method based on design archetypes stored in the company database.

**Keywords:** design archetype; systematic design method; knowledge-based engineering; CAD-based tool; mechanical transmissions

---

## 1. Introduction

The design of industrial products exploits novel approaches for material selection, manufacturing and assembly processes, simulation, and life cycle management, however, the design is still heavily based on the experience of designers. Knowledge transfer from experts to young designers is pursued with conservative approaches and unstructured communication, with many limitations even within the same company. On the one hand, the lack of formal design knowledge limits access to prior experience and knowledge by designers. On the other hand, knowledge management is critical in industry, since it is highly expensive nevertheless ephemeral due to staff turnover and the increasing use of outsourcing. Therefore, knowledge management methods have been developed by researchers to better exploit individual and collective knowledge [1–5].

Engineering design is described in the systematic approach of Pahl and Beitz [6] as a sequence of the following four phases: (1) task Clarification, (2) conceptual design, (3) embodiment design, and (4) detail design. Following a top-down approach, the system is broken down into its compositional subsystems and, similarly, the knowledge of the whole design problem is refined into more detailed subproblems. Therefore, in the design archetype (DA) implementation, the design knowledge management approach follows the same systematic structure to capture, store, and reuse knowledge models of products, processes, and manufacturing resources.

In order to save costs and time, most industrial products are designed by adapting existing ones to meet new requirements [7–9]. In the embodiment design phase of automotive subsystems, for instance, designers have to reuse the already available computer-aided design (CAD) models, by simply adapting the parameters of their features to new requirements [7]. As a result, the same parametric models are used in different product variants, with the collateral effect of increasing the complexity of the models themselves in the case of specific adjustments. Therefore, design knowledge management needs to specifically consider the variant design process. In variant design, not all the design phases have to be carried out again. The constraints of costs, carry over, reuse, and supply chain policies force the implementation of specific design solutions. In variant design, the designers have to enter the top-down design process in the embodiment or even the detail design phases. Moreover, the adaptation to existing subsystems can cause many bottom-up issues, so that problems of optimization are likely to arise.

Designers often are required to deal with products with similar structures, with only minor differences related to specific requirements [2,10–12]. Therefore, most knowledge-based engineering (KBE) applications for mechanical design follow three main approaches, i.e., the automation of complex design tasks, the reuse of design solutions, and knowledge-based tools [13–15]. The feature design can be automated, also taking into account technology specific data. Many case studies can be retrieved from the literature such as, describing a tool for designing hot forging dies [16], a tool for developing virtual prototypes of multifunctional agricultural machines based on real component behavior [17], a web-based tool for identifying the undercut feature of molds for injection molding and for the automatic design of parting surface [18], a configuration tool for the generation of conceptual train geometry for design automation and reuse [19], an agent-based model representing product development as the learning and application of knowledge coming from product and development process data [20], an ontology representing the information and design knowledge in product design process [21], or a library of components for the automatic definition of the finite element model of an automotive structure [22]. Other works have focused on manufacturing the following: an ontology-based product design framework for manufacturability verification and knowledge reuse to support the sharing and reuse of design and manufacturing knowledge [23], a failure-assessment based design revision of manufacturing equipment based on the lessons learned from forensic metallurgical analysis [24], and an approach to capturing systematic knowledge for manufacturing process innovation [25].

These multiple approaches achieve the KBE application with very specific tools. However, the complex products we are dealing with would require an effective integration. In particular, they require an integrated approach to retrieve and reuse existing CAD models and technical documentation. Furthermore, many mechanical products have been developed with the systematic design approach [6]. Therefore, it is very effective to adopt the same approach for their knowledge management.

In many companies, designers frequently face projects with the same design phases for products with similar structure but just small variants for specific requirements. Therefore, designers could benefit from the support of a knowledge tool that aids the execution of design tasks. A possible solution could be the application of archetypes of systems, defined as solutions for facilitating sharing knowledge and system interoperability [26]. Therefore, we introduce the design archetype (DA), a design tool that stores the knowledge on a subsystem design in its algorithms and supports the designer in selecting and dimensioning the most suitable working principles to address the project

requirements [4,27–29]. Following the systematic approach, a specific contribution is the organization of the tool on the following two levels: the first is the layout and the second consists of the linked parametric models. With the aim of discussing the method for the DA implementation, we report its application in two case studies, selected since they are complex assemblies requiring an integrated approach to retrieve and reuse existing CAD models and technical product documentation.

In particular, we focus on mechanical transmissions, which are widespread systems in industry, from vehicles to renewable energy, and from machine tools to automation and robotics [30–33]. Many studies focus on transmission machines from multiple perspectives, such as manufacturing and finishing [34–38], or metrology and tolerances [30,39–41], but only a few of them deal with their design knowledge management. The studied subsystems for mechanical transmissions are both designed and manufactured by a leader multinational corporation and are definitely defined mature products with stable technologies. As mature technical products, they are particularly suitable to be addressed by a DA application because of the following:

- The designer quite often faces design problems that have been previously solved by someone else for different requirements;
- The company had and has a complete view over their whole lifecycle;
- The applications of the method use the PTC Creo® package integrated with MathWorks Matlab® environment.

This paper is organized as follows: First, the two-level systematic method used for the development of machine DAs is introduced in Section 2; Section 3 reports the two case studies for the definition of a DA for mechanical transmissions; in Section 4, the results of the DA implementation are discussed; and the conclusions are summarized in Section 5.

## 2. Method for Design Archetype Development

A DA is intended as a tool to support the systematic design process with specific design knowledge embedded in its rules [42].

The selection of the subsystem to develop must be based on a careful assessment of the required effort and the expected benefits. The convenience in a design process is greater for DAs addressing basic functions in the system, rather than DAs for auxiliary functions [6]. Function maturity is another factor to be evaluated for assessing the DA usefulness. In fact, experience on the lifecycle of the subsystem, including design tasks, production, maintenance services, and disposal increases the knowledge in the DA development. The number of design variants of the subsystem for performing the same function could highlight a bad formalization of knowledge. Finally, the task complexity determines the number of rules to be implemented to describe the design task.

The DA workflow is shown in Figure 1, with a top-down approach to the design problem. The new subsystem requirements are the inputs. The design task clarification is performed using a spreadsheet with a Graphical User Interface (GUI) where the user must enter the input requirements in a suitable, and therefore properly analyzed format. Then, the first layer, i.e., the layout, processes the input requirements and addresses the solution of the design problem for a specific design concept. In the second layer, the CAD models, the DA updates the feature parameters of the best candidate model, producing the first CAD model draft. The DA delivers the tentative CAD model, and, if needed, also provides the technical documentation for design dimensioning and further verification.

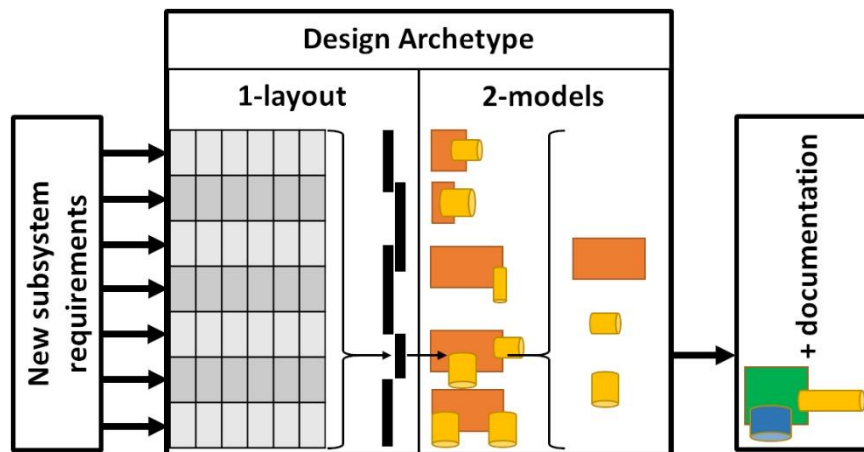

Figure 1. Design archetype as a top-down design tool.

A DA stores the design knowledge of a specific subsystem. A repository of DAs supports designers in the integration of the subsystems. A DA must be developed by experts, but it can be widely used thanks to its GUI, which needs to be clear and user friendly.

The development of a DA follows three main phases, as shown in Figure 2, in accordance with the systematic design approach. The development of a DA should start from the analysis of an existing and well-functioning system. Then, a reverse engineering approach leads to model the archetype of the solution. In particular, the DA catches the best design experience about the subsystems and stores all the information needed for their dimensioning and modeling.

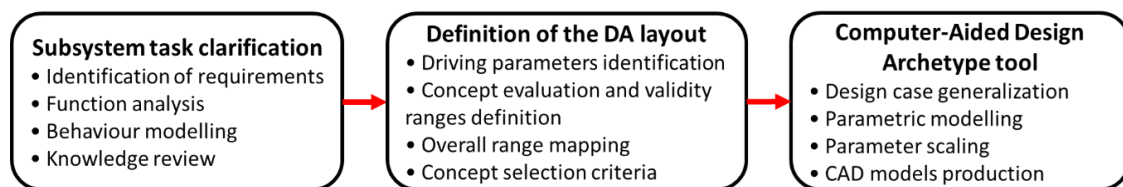

Figure 2. Method phases for the development of a design archetype.

### 2.1. Subsystem Task Clarification

The knowledge retrieved in the company must be organized in order to be useful for DA development. Generally, the complexity of a system is so high that we need to divide it in simpler subsystems, each one delivering a clear function. Then, each design variant must be analyzed for the following:

1. Identification of the quantitative and qualitative requirements for the subsystem as follows:

- Guiding parameters for the system, from design statements and requirement lists;
- Layout constraints, from kinematic schemes of the whole system;
- General rules and constraints, from international and internal standards and best practices.

2. Function analysis of the subsystem, from top to bottom levels, and connection of each subfunction to the requirements as follows:

- Design criteria retrieved from the knowledge of senior designers, datasheets, and reports;
- Charts with function boxes, transformation of material, energy, and information, as in [6];
- Function boxes connected by flows of material, energy, and information, in order to determine the interfaces of the boxes in the system and analyze rules for compatibility between subsystems;
- Failure modes and effects analysis (FMEA) for critical functions.

3. Behavior modeling through mathematical models, formulae, theories, and ranges for parameter validity as follows:

- Boundary conditions, general assumptions, and reference results, from design reports;
- Fundamental features of the system, from two-dimensional (2D) drawings and 3D CAD models.

4. Review of the gathered knowledge as follows:

- Concepts refinement through interviews with senior engineers;
- Improvements of concepts in light of researches and developments.

### 2.2. Definition of the Design Archetype Layout

The layout is the top layer of a DA, conceived to process the input requirements from the designer and resulting in the selection of one possible design concept. Each predefined concept is valid for a subrange of the possible input requirements. The method for the definition of the DA layout requires the following steps:

- (1) **Driving parameters identification** Analysis of design specifications, mathematical models, and checklists to identify the driving parameters that mainly describe the difference between the different design concepts;
- (2) **Concept evaluation and validity ranges definition** Evaluation of the limits for the driving parameters in the subranges for each design concept and definition of the possible selection range;
- (3) **Overall range mapping** The union of all the subranges of validity is the range of input requirements for the whole DA. Overlaps between validity ranges and subranges can occur since the concepts are not assumed as mutually exclusive. This requires a decision by the designer;
- (4) **Concept selection criteria** Definition of an algorithm to link the set of input parameters to a set of parameter subranges in order to select a specific design concept.

### 2.3. Computer-Aided Design Archetype Tool

The DA is implemented as linked with a CAD software. According to the guidelines described in [43–45], CAD systems represent state-of-the-art tools for lowering the accessibility level and enhancing KBE in industry. Again, the development of the CAD-based approach to machine design has proven to be effective in many industrial fields for the analysis and simulation of complex machines [46–52]. Therefore, a DA can integrate parametric CAD modeling in order to support the selection and design of a machine subsystem. The steps in this last phase are the following:

- (1) **Design case generalization** Each design concept is embodied in the parametric CAD model of a verified design case.
- (2) **Parametric modeling** Effective rules must be defined for feature updates. Most CAD software support the link of the variables of models of parts and assemblies to the formulae in the cells of a spreadsheet. Other software enables the automatic update of the variables thanks to specific software languages, or by using the equation environment or an Application Programming Interface (API). It is easier to enter the design requirements as input in the spreadsheet cells, automatically processing them with a formula in other cells that accordingly update the CAD models.
- (3) **Parameter scaling** A pantograph construction consists in simply scaling all the dimensions, but it rarely works for mechanical subsystems. The similarity criterion consists in scaling some parameters while at least one physical relationship (e.g., kinematics, Hooke, Newton, Froude, Reynolds, Biot ones) is kept constant [6]. For the parameters that cannot be regulated by maths, such as fits and tolerances, cast wall thickness, chemical and heat treatments, prevailing company or international standards, the values from two or more design cases can be simply used as data points for a value interpolation.

- (4) **CAD model production** The features of the models are updated in such a way to satisfy the input requirements. The DA is conceived to be widely used in design departments and not merely a prerogative of expert developers, and therefore the DA is made user-friendly by adopting a graphic interface for setting input and analyzing output data.

### 3. Case Studies

This section reports two case study applications of the method on the definition of a DA for the subsystems of mechanical transmissions. The selected case studies are a clutch and a final gear reduction for agricultural tractor transmissions. They are proposed as DA applications since they present the full implementation of all the DA steps. They are widespread industrial applications, not only in the agricultural field. Since they are renowned and mature products, the designers have a comprehensive knowledge over the whole lifecycle of these products. Therefore, starting from the analysis of these existing and well-functioning systems, we applied the proposed steps, leading to modeling the DA. With the selection and adaptation of relatively few types of transmission elements, the tractor manufacturer can design a wide variety of transmissions for its new tractors or other vehicles [53].

#### 3.1. Transmission Clutch

##### 3.1.1. Task Clarification and Function Analysis

The power train generally includes a transmission clutch or other means for interrupting the flow of power to the drive wheels. A clutch provides a means for the tractor operator to start a smooth delivery of power to the transmission, to interrupt power while the transmission gear ratio is being changed, and to interrupt power when the tractor is to be stopped [53]. Moreover, one (or more) separate clutch(es) can also be provided to interrupt the flow of power to the power take-off drive [53]. A transmission clutch is a knowledge intensive subsystem, with a complexity high enough for requiring a deep functional analysis, but manageable enough to be a feasible application for the DA development.

First, the clutch design variants are analyzed by reviewing datasheets and transmission schemes for their function in the system, CAD models and drawings for dimensions and parts, design reports for simulations, dimensioning, company Product Lifecycle Management (PLM) on materials, manufacturing, and standards. The clutches are grouped as follows:

- (1) **Power take-off (PTO)** Operation assisted by the control system, thus not prone to uneven and stressed actuation;
- (2) **Continuously variable transmission ranges (CVTR)** Comfort application with little disc slips, thus subject to low thermal stresses;
- (3) **Gear box (GB)** Used for gear shift but not for moving the tractor from standstill, thus with medium stresses;
- (4) **Power shift ranges (PSR)** Used to select ranges and start the tractor from standstill, thus very high load and heat stresses.

A tractor transmission requires several clutches with specific functions and requirements:

##### 1. Geometry:

- Layout, including shaft configuration;
- Nominal dimensions, including overall size, input and output shaft diameters, housing diameter.

##### 2. Kinematics:

- Displacement of springs and piston;
- Gaps between discs and shafts.



3. Loads:

- Torque passed from input to output shafts;
- Safety factor as a dimensioning criterion;
- Maximum pressure on the discs;
- Engagement smoothness.

4. Duration:

- Dissipation of energy through friction.

Therefore, due to a high number of parameters it was not possible to define a few concept models with continuously variable parameters. The design problem could be simplified by fixing a number of main parameters levels. This produced 54 possible solution concepts, with further possible adjustments in the detail design phase. An example of the clutch structure is shown in Figure 3.

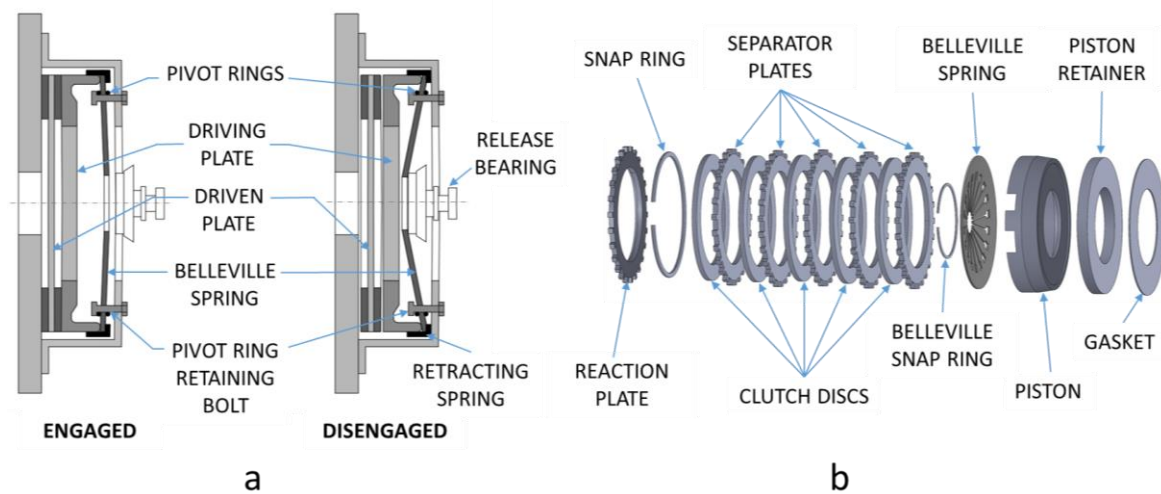

**Figure 3.** Parts of a transmission clutch with Belleville (diaphragm) spring and its functioning. (a) Single; (b) 5 clutch discs version.

The functional FMEAs are fundamental tools for linking the subfunctions of each clutch component to the transmission requirements, as shown in Table 1.

**Table 1.** Clutch parts linked to the requirements through the subfunctions they deliver (extract).

Part	Subfunction	Requirement
Reaction Plate	Transfer torque	Transmissible torque
	Transform energy	Transmissible torque
		Lining pressure
	Lubricate/Cool	Dissipated energy
Housing	Transfer torque	Transmissible torque
	Connect	Geometry
	Lubricate/cool	Life
Piston	Transform energy	Transmissible torque
	Seal	Transmissible torque
	Lubricate/cool	Life
Belleville spring	Store energy	Transmissible torque
		Life

The main function of the subsystem is to engage or disengage two shafts, to transmit or not transmit the torque between them, as encased by the dotted box in Figure 4. Inside the box, all the subfunctions are drawn in relation to the structure of the subsystem. The subfunctions are connected by flows of material (double line), energy (solid), and information (dashed, but not used here). Then, these flows are described by equations between the fundamental parameters, or at least by a regression analysis model. These parameters are continuously variable numbers or tabulated in the catalogues of suppliers.

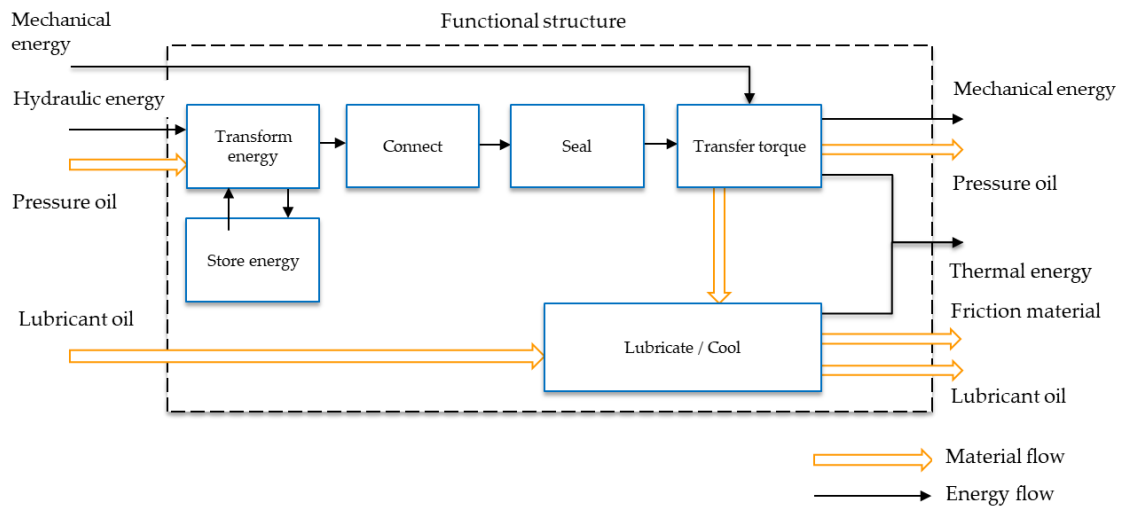

Figure 4. Function structure of a transmission clutch.

### 3.1.2. Concepts Layout of the Clutch Design Archetype

The layout level of the DA is conceived to address the selection of a design concept for the specific requirements, even if each design problem usually has more than one possible solution, both good and weak. Therefore, the design problem is simplified by splitting the range of possible input requirements into subranges, which lead to a few fixed levels of the main parameters. Three configurations address the design problem, as reported in Table 2, fixing different values for the following:

- Maximum rotation speed without risk of accidental engagement or failure in disengagement;
- Maximum allowable speed difference between rotor and stator discs during engagement.

Table 2. The three configurations for the design archetype (DA) layout.

Parameters	Configurations		
	1	2	3
Max rotation speed (rpm)	6000	4500	6000
Max relative speed during engagement (rpm)	600	1000	2500

The three configurations are defined according to the physical limits resulting from the task clarification and functional analysis. Configuration 1 is conceived for the working conditions of CVTRs, with high rotation speed but with easy engagement between shifts already accelerated to the same speed or with little slip at most. Configuration 2 is an intermediate one, suitable for relatively low speed but with significant slip. Configuration 3 is conceived for the GB working conditions, also suitable for fast ranges, working at high speed with high slips.

Thereafter, in order to comply with money saving policies, the DA results in just three clutch sizes, D1, D2, and D3, varying the outer diameter of the housing. Figure 5 shows the torque capacity of the



clutch as a function of the number of its discs, determined by the equation model in the DA layout. Beyond a certain number of discs,  $N^* = 10$ , the percentage variations are so limited that it does not justify the complexity of the model. Therefore, this design variable is restricted in the range from  $N_1 = 5$  to  $N_6 = 10$ . Finally, other dimensions for standard and commercial clutch parts are fixed to comply with cost reduction policies.

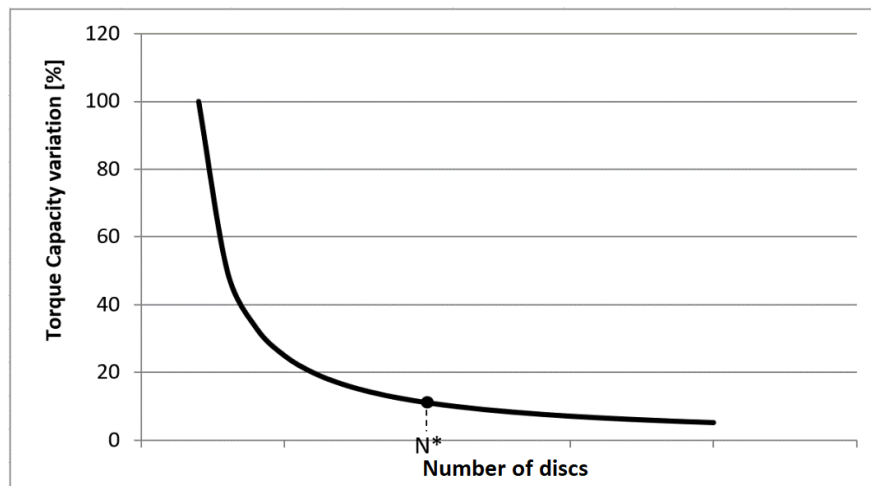

Figure 5. Variation of the torque capacity by increasing the number of friction discs.

The DA of the clutch is able to meet all the requirement ranges of the transmissions designed in the company. The torque capacity is addressed by different combinations of parameters, such as configuration, number of discs, and their outer diameters, as shown in Figure 6. The DA is conceived to give certainty to the design problem, without making the decision rigid. Thus, there is quite a large overlap between the requirement ranges, in order to choose the optimal dimensions once the function requirements are met.

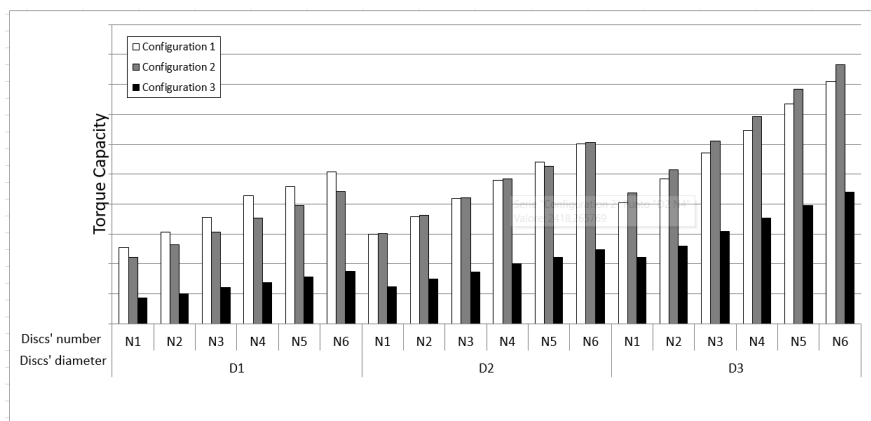

Figure 6. Torque capacity requirement addressed by the clutch DA.

### 3.1.3. Integration of CAD Models with Knowledge Stored in Spreadsheets

Once the main design problem has been addressed by the previous layout, the clutch DA delivers a CAD model, the parameters of which are linked together by the physical laws complying with mechanical and thermal constraints. The designer must enter the following parameters in a GUI window, linked to a datasheet (e.g., Microsoft Excel):

- Dynamic and thermal requirements;

- Lubrication oil properties and friction material;
- Reused components as constraints;
- Safety factor;
- Main dimensions.

And it returns:

- Dimensions of the parts;
- Clutch torque capacity;
- Maximum transmissible torque;
- Maximum disc pressure;
- Specific dissipated energy to transmit the maximum torque;
- Verification of the fatigue life.

A design concept is quickly generated from the datasheet so that the designer can evaluate performances and feasibility. If the concept is rejected, a new concept is generated with slight parameter variations. The datasheet is used to produce the CAD models of the clutch assembly and parts. Thus, the characteristic dimensions are automatically updated, as shown in Figure 7.

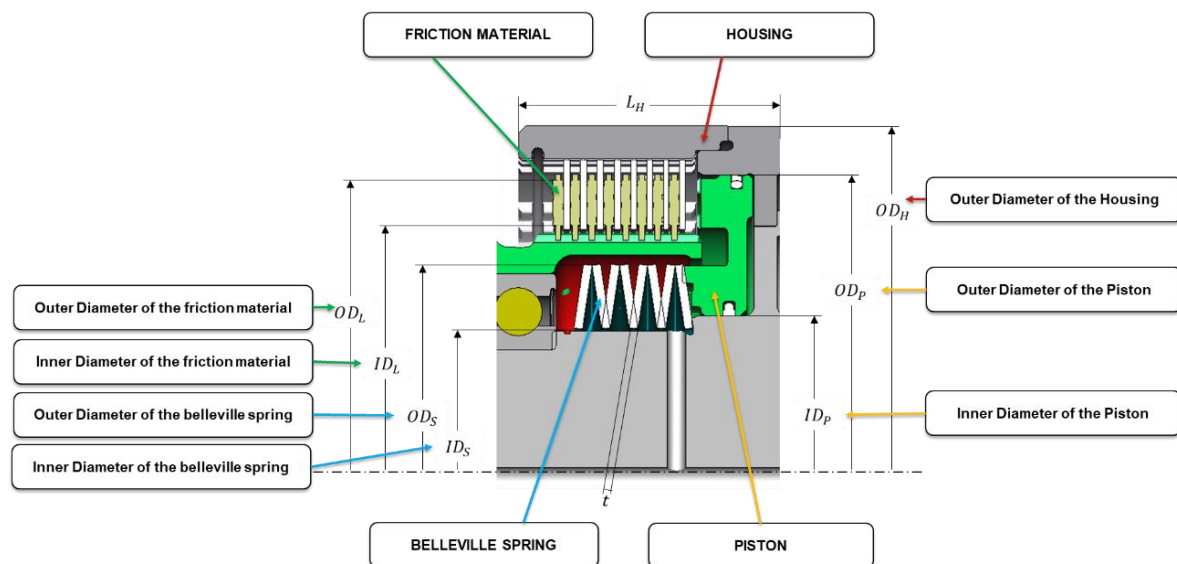
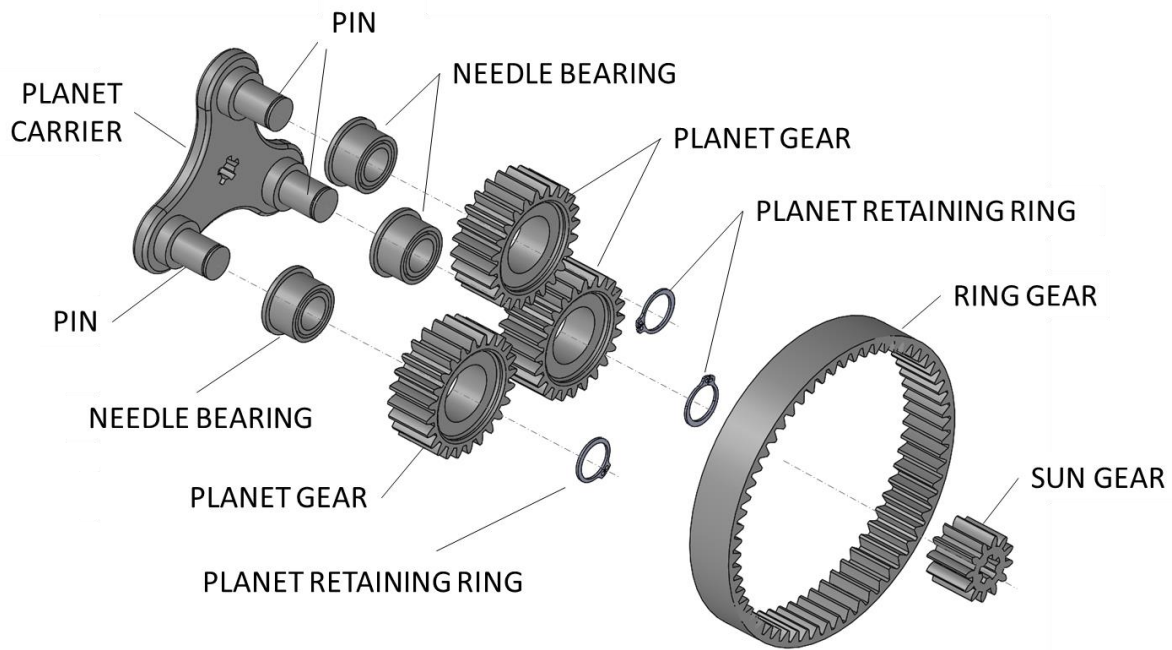

**Figure 7.** CAD model of the clutch produced on the basis of the DA datasheet.

### 3.2. Final Gear Reduction

#### 3.2.1. Task Clarification and Functional Analysis

The tractor transmission ends at the wheel axles with a final planetary reduction. The final drive lets the drive wheels run at a much slower speed and with a much higher torque than the earlier parts of the drive train [53]. A planetary gear set (Figure 8) is built into the axle of each drive wheel. The final drive shaft is attached to the sun gear on one end and it is spline connected on the other end to one of the side gears in the differential. The ring gear is held stationary in the axle housing, and the rear axle shaft is driven by the planet carrier. The rear axle shaft extends well beyond the axle housing. The drive wheels can be attached at different points along the rear axles to change the drive wheel spacing [53].



**Figure 8.** Exploded view of the main components of the planetary gear set as a part of the final reduction.

High strength, fatigue resistance, and low noise are required for this demanding application [54]. All the actual final reductions are analyzed with the method described in Section 2. The component subfunctions are analyzed and linked to the transmission requirements, as shown in Table 3. The input requirements to the DA can be grouped as follows:

**Table 3.** Parts of the final reduction linked to the requirements through their subfunctions (extract).

Part	Subfunction	Requirement
Planetary gear set	transfer torque	transmissible torque
	vary speed	output speed
Planet carrier	transfer torque	transmissible torque
	support/connect	geometry
Pin	transfer torque	transmissible torque
	support/connect	geometry
	lubricate/cool	life
Needle bearing	support/connect	geometry
		life

1. Geometry:

- Overall size;
- Meshing conditions for gears.

2. Kinematics:

- Speed reduction to deliver the expected final speed.

3. Loads:

- Torque capacity;
- Bending moment capacity.

#### 4. Duration:

- Friction condition.
- Heat dissipation.

The main function of the subsystem is to reduce the angular speed from an input shaft to the output one, as encased by the dotted box in Figure 9. Inside the box, all the subfunctions are investigated and connected in a functional analysis structure. The functional analysis flows are formalized with formulae, transforming the inputs into outputs. Fundamental relations are the gear transmission ratio, and the safety factors for the contact stress and for the bending moment.

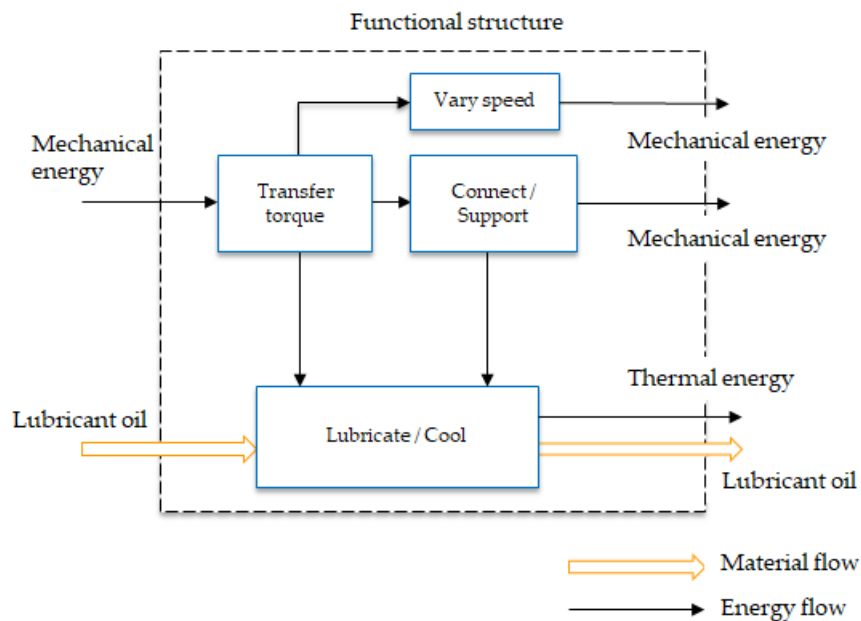

**Figure 9.** Function analysis of the final reduction of a tractor transmission.

Because of the complexity of the system (Figure 10), the number of possible solutions was limited by fixing some of the driving parameters based on the company's best practices. The archetype suggests a preliminary solution that respects the company standards and that can be further optimized and detailed.

After analyzing the design variants, reference values for the main parameters are defined. The experience of senior designers is fundamental for reviewing those parameter values in order to avoid conflicting effects and bias for maintaining those functions that somehow already worked.

#### 3.2.2. Concept Layout of the Design Archetype of the Final Gear Reduction

The analysis of the design variants reveals that the definition of the final drive model is an under defined problem. As already explained for the clutch, there are countless possible design variants for the final reduction from the input requirements. Again, the certainty of this systematic design tool is pursued by fixing simple constraints between the parameters governing the dimensioning of the final reduction. The most important parameters are the gear normal modulus  $m_n$ , the ratio  $\lambda$  between the teeth width and their module, and finally the pressure angle  $\alpha$ . Figure 11 reports the gear modules as varying with the DA rules according to the power to be transmitted, the dashed lines as compared with the values in the design variants, the point values. The dimensionless  $m_n$  is reported as divided by the specific  $m_n$  dimensioned for the subsystem when transmitting 100HP, to avoid disclosing company data.

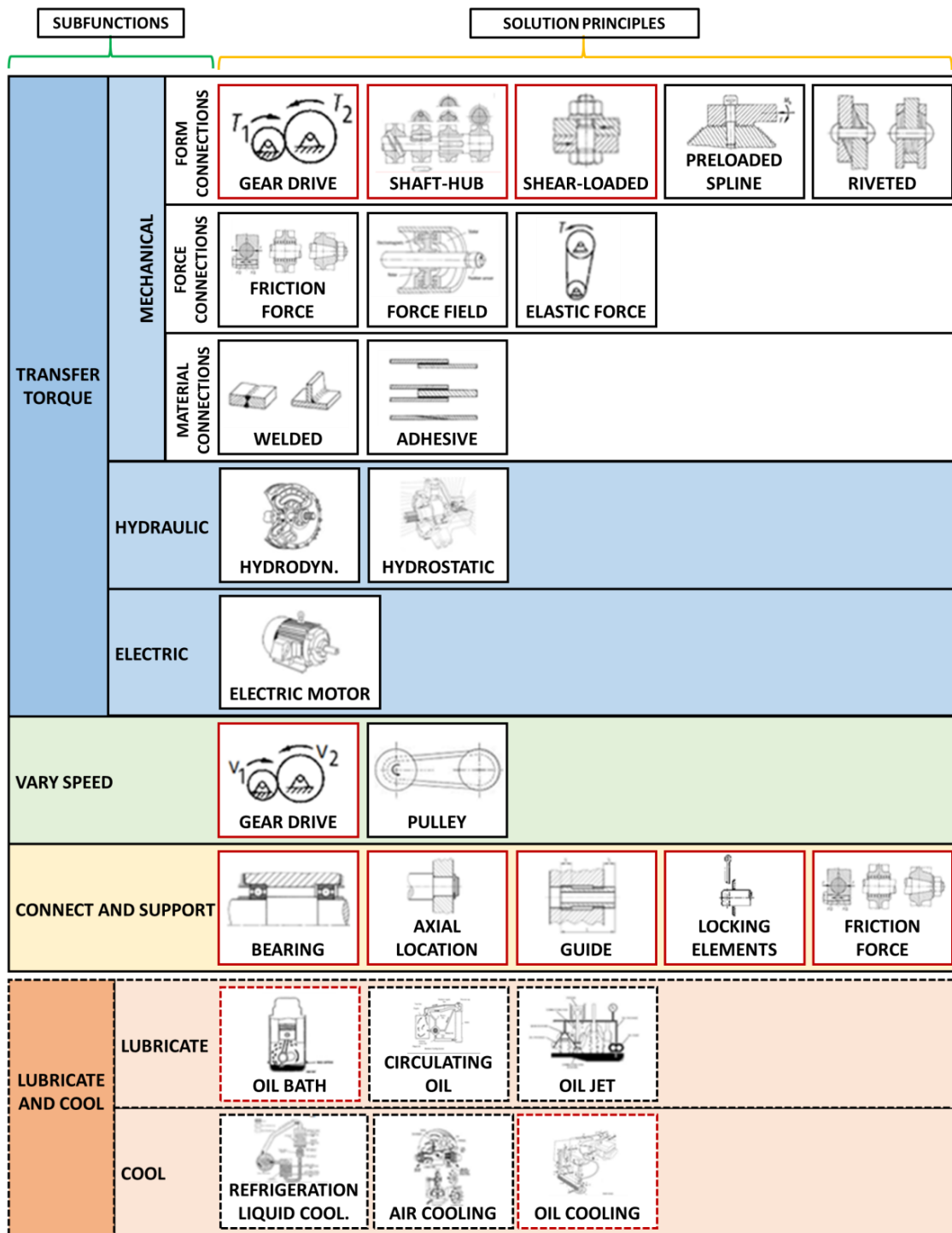

Figure 10. Classification of subfunctions and possible solution principles.

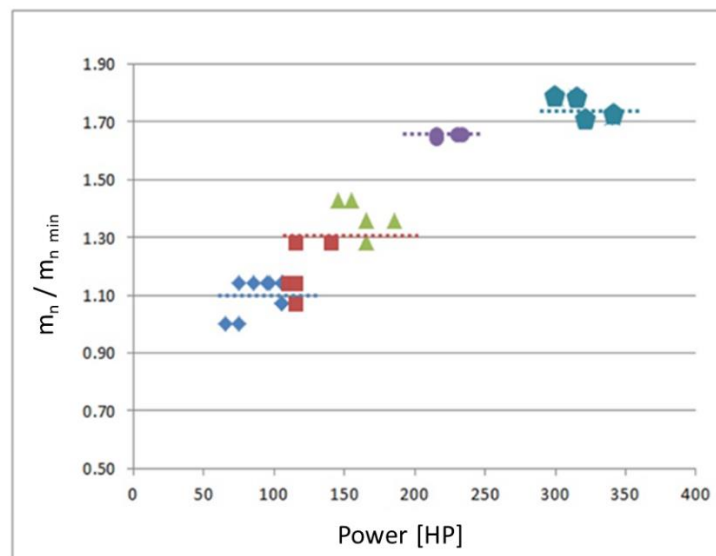

Figure 11. Gear modules for the final reduction DA.

In addition to the formulae between inputs and outputs for the flows in the functional analysis, the DA resorts to design best practices for the following:

- (1) **Assemblability** Linking the number of planet gears in the gear set and the number of their teeth;
- (2) **Vibrations** Very reduced in the gear set if the planets have an odd number of teeth;
- (3) **Interference** Minimum value of teeth of the sun gear to avoid interference between gears;
- (4) **Company experience and costs** Number of planets, simple or compound planetary gear set, cantilever or simply supported pins.

### 3.2.3. CAD Models Driven by Knowledge Base

The knowledge retrieved for the final gear reduction is implemented in formulae in the spreadsheet cells. The requirements are entered which include kinematic conditions (input power, torque, and speed), minimum safety factor and life, transmission ratio, interface dimensions (center distance), material, and lubricant oil features. The knowledge model outputs the dimensions of all the part features, up to gear diameter and teeth geometry. The outcome is automatically generated by the DA by updating the parameter values of a 3D CAD model in accordance with the knowledge base rules contained into the spreadsheet, as shown in Figure 12. Each component of the system, as well as the entire assembly, is updated in accordance to the values of the spreadsheet cells (e.g., increasing the number of teeth of the planet or the ring, the number of planets, the facewidth, etc.). The outcome consists of a first draft embodiment of the design concept. The design process continues with detailed optimizations with simulation tools and design for manufacturing issues.



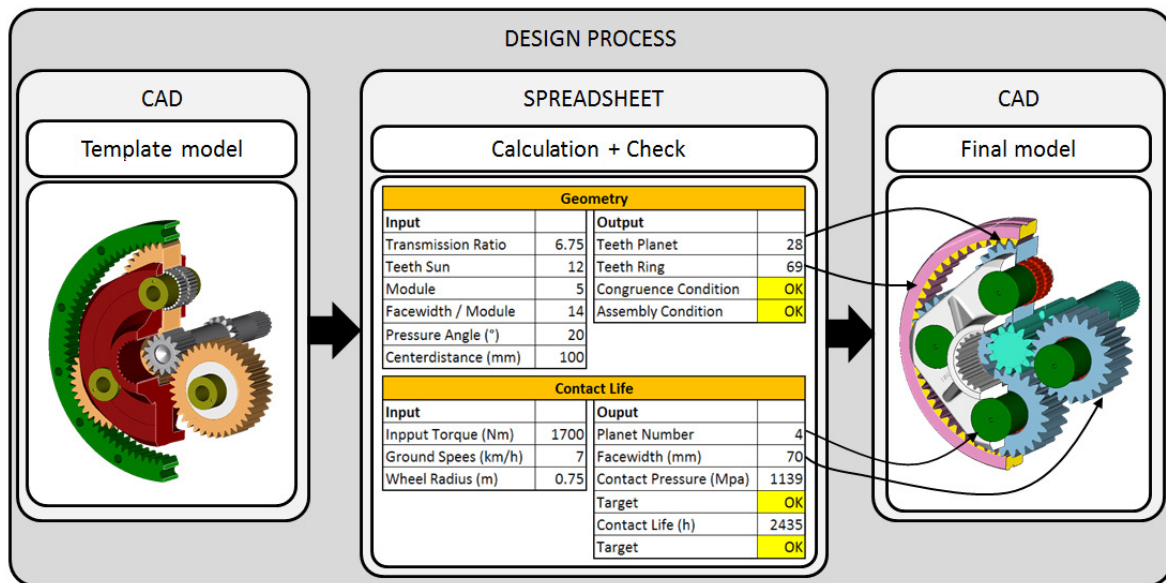

**Figure 12.** Design process (inputs, outputs) for the generation of the computer-aided design (CAD) model.

#### 4. Results and Discussion

The case studies present the development, application, and evaluation of two DAs, following the introduced systematic approach. The knowledge from the designers' experience is formalized in an application (i.e., the DA tool and its interface) that supports the solution of the design problems in a transparent and traceable process. The developed interface was tested by the company designers and finally judged as easy to use, based on well-known tools (e.g., CAD software, spreadsheet, etc.).

Thanks to the DA graphical interface, the designer is able to interactively modify the requirements and again examine their effect on the machine model. Therefore, on the one hand, the DA user has clear control over the design choices, since the DA layout splits the requirement domains into different solution concepts, improving the design process awareness. In particular, the DA avoids impossible fields of application and leaves the possibility to move with operational certainty and without constraints within established ranges.

On the other hand, the DA does not hinder the designer's creativity, since it is open to modifications, if new research leads to an innovation. The implementation of changes and the creation of functional variants is guaranteed by the structure of the DA.

On the highest level (first layer), the DA can be updated with new technical solution thanks to its functional deployment, substituting working principle solutions, and therefore generating new variants.

On the lowest level (second layer), the DA allows dimensional and geometric changes thanks to the use of parametric modeling and tools, since most CAD software support the configuration of parts and subsystems through changing the parameters in linked spreadsheets, as well as by means of equations or specific programming interfaces.

Concerning creativity in design, fixation is a risk. Design fixation can occur due to the involvement of expert designers, who can show blind adherence to a set of already known ideas [55]; the designer consideration of the original functional structure of the product (e.g., functional decomposition, and morphology) [56,57]; the use of CAD tools; and related CAD facilitated design [58]. If these factors represent a general limit to design creativity, they only partially affect the DA for two main reasons. The first one is due to the selected target of systems and products for the DA development. In fact, the DA approach originates from the need for knowledge management of mature products, with stable technologies, which the company has a complete view over their whole lifecycle. We cannot exclude

innovation in these fields of application, but this is not be the main goal of design efforts. Designers, as well as companies, aim to finely tune and optimize these mature products instead of completely upsetting their structures [59]. The second reason is due to the two layers structure of the DA, Starting from the first layer, the designer can question the entire structure of the DA, modifying the systems or subsystems, as well as generating simpler morphological variants in the second layer.

Finally, some remarks about the two case studies. A DA is developed and applied for designing clutches in tractor transmissions, as a first case study. The clutch DA is assessed and proves to be a suitable KBE application, while the knowledge retrieved was found to be sufficient for the DA definition. However, the high number of clutch parameters limits the definition of a few concept models with continuously variable parameters. Therefore, the design problem is simplified by fixing a number of main parameter levels. Accordingly, 54 possible solution concepts are produced, with further possible adjustments in the detail design phase. As a final result, this simplification enables the automatic modeling of such a complex system, and a CAD model is embodied and updated in accordance with a datasheet, which is a common tool in the design process. Future works should deal with the assessment of the impact of the DA application in relation to conventional design processes. Again, verification criteria could be added to the DA, such as the thermal fluid dynamics analyzes, and even provide updated models in third party simulation environments. A second DA is developed for the planetary gear set for tractor transmissions. The systematic methodology for knowledge capture results effective. Starting from the analysis of the actual machine and its design documentation, the fundamental parameters are identified, linked to the functions and subfunctions of the system. Since the design of the planetary gear set can generate countless solution variants for the same initial requirements, the development of the DA requires the simplification of the design problem with the following assumptions:

- Reference values are defined as targets for dimensioning the solution;
- As few architectures of working principles as possible are adopted according to design best practices;
- Simple rules are fixed for the kinematics and dynamics parameters that strongly influence the dimensioning process.

The knowledge is formalized in spreadsheets, which originates the DA tool that processes the requirements, delivering the dimensions of all the components. A CAD model is automatically generated by these parameters as a design concept, which can be further detailed by the designer. As future works, verification criteria should be added to the DA (e.g., dynamics analyses), to provide updated black box models to be used in model-based simulation environments for interactive design verification.

The proposed case studies give us the chance to draw some final remarks about the development of a DA. The aim of a DA is to collect and synthesize the knowledge about a product/system (as owned by the designers within a company) and then to reuse it for the development of variants. During the product/system analysis, we propose its functional decomposition since the definition of the working principles is based on this functional analysis. By changing the working principles, we create a new product/system variant or configuration. The examples of function analysis shown in Figure 4 as well as Figure 9 are respectively based on the traditional concepts of the transmission clutch and final gear reduction. However, generally speaking, the designer is free to modify the product concept during the conceptual stage (according to Pahl and Beitz [6]) and so to propose alternative functions or alternative sources of energy, material, and information to perform a task in a different way.

## 5. Conclusions

This paper presents the DA as a methodological support to retrieve, store, and reuse design knowledge. The DA development is evaluated by defining a design tool for complex products, in particular subsystems for mechanical transmissions. Concerning the two case studies, the systematic

approach for knowledge capture and formalization proves to be effective, and capable of managing systematic design issues. DAs support the designer in the selection or the design of the most suitable machine, based on the formalization of prior knowledge.

A DA enables the preservation of design knowledge as a core value for a company, overcoming the knowledge loss resulting from staff turnover and outsourcing. The use of a DA in the design process also reduces the problems due to knowledge disorganization and limits the number of design loops. All the developed DAs are currently used in the company to automate the design tasks for machine variants.

Finally, the proposed DA based approach can easily be extended to other mechanical machines, such as pumps and other hydraulic components, compressors, vehicle components, as well as electric motors and machines.

**Author Contributions:** Conceptualization, A.V., F.G. and F.L.; methodology, A.V. and F.G.; validation, A.V., F.G. and F.L.; writing—original draft preparation, A.V. and F.G.; writing—review and editing, A.V. and F.G.; supervision, F.L. All authors have read and agreed to the published version of the manuscript.

**Funding:** This research received no external funding.

**Acknowledgments:** The authors gratefully acknowledge Mariele Peroni, Michele Forte and Monica Morelli for their valuable technical support and contribution.

**Conflicts of Interest:** The authors declare no conflict of interest.

## References

1. Ahmed, S. Encouraging reuse of design knowledge: A method to index knowledge. *Des. Stud.* **2005**, *26*, 565–592. [[CrossRef](#)]
2. Lovett, P.J.; Ingram, A.; Bancroft, C.N. Knowledge-based engineering for SMEs—A methodology. *J. Mater. Process. Technol.* **2000**, *107*, 384–389. [[CrossRef](#)]
3. Probst, G.J.B. *Practical Knowledge Management: A Model That Works*; Prism: Cambridge, MA, USA, 1998; pp. 17–29.
4. Dani, S.; Harding, J.; Case, K.; Young, R.; Cochrane, S.; Gao, J.; Baxter, D. A methodology for best practice knowledge management. *Proc. Inst. Mech. Eng. Part B: J. Eng. Manuf.* **2006**, *220*, 1717–1728. [[CrossRef](#)]
5. Do, N.V.; Nguyen, H.D.; Mai, T.T. A Method of Ontology Integration for Designing Intelligent Problem Solvers. *Appl. Sci.* **2019**, *9*, 3793. [[CrossRef](#)]
6. Pahl, G.; Beitz, W.; Feldhusen, J.; Grote, K.H. *Engineering Design: A Systematic Approach*; Springer: London, UK, 2007.
7. Schubert, S.; Nagarajah, A.; Feldhusen, J. An Approach for More Efficient Variant Design Processes. In Proceedings of the International Conference on Engineering Design, ICED11, Technical University of Denmark, Lyngby/Copenhagen, Denmark, 15–18 August 2011.
8. Nurcahya, E. Configuration instead of New Design using Reference Product structures. In *The Future of Product Development: Proceedings of the 17th CIRP Design Conference, Berlin, Germany, 26–28 March 2007*; Springer: Berlin, Germany, 2007; pp. 1–10.
9. Feldhusen, J.; Nagarajah, A.; Schubert, S.A. Data Mining Method for selecting the suitable existing product variant as a development base for a new order. In *Proceedings of DESIGN 2010, the 11th International Design Conference, Dubrovnik, Croatia, 17–20 May 2010*; Faculty of Mechanical Engineering and Naval Architecture, University of Zagreb: Zagreb, Croatia, 2010; Volume 2, pp. 895–903.
10. Sandberg, M.; Tyapin, I.; Kokkolaras, M.; Lundbladh, A.; Isaksson, O. A knowledge-based master model approach exemplified with jet engine structural design. *Comput. Ind.* **2017**, *85*, 31–38. [[CrossRef](#)]
11. Demoly, F.; Roth, S. Knowledge-based parametric CAD models of configurable biomechanical structures using geometric skeletons. *Comput. Ind.* **2017**, *92–93*, 104–117. [[CrossRef](#)]
12. Volpe, Y.; Governì, L.; Furferi, R. A computational model for early assessment of padded furniture comfort performance. *Hum. Factors Ergon. Manuf.* **2015**, *25*, 90–105. [[CrossRef](#)]
13. Colombo, G.; Pugliese, D.; Rizzi, C. Developing DA applications in SMEs industrial context. *IFIP Int. Fed. Inf. Process.* **2008**, *277*, 69–82.

14. Han, Y.-H.; Lee, K. A case-based framework for reuse of previous design concepts in conceptual synthesis of mechanisms. *Comput. Ind.* **2006**, *57*, 305–318. [[CrossRef](#)]
15. La Rocca, G.; van Tooren, M.J.L. Enabling distributed multi-disciplinary design of complex products: A knowledge based engineering approach. *J. Des. Res.* **2007**, *5*, 333–352. [[CrossRef](#)]
16. Kulon, J.; Mynors, D.J.; Broomhead, P. A knowledge-based engineering design tool for metal forging. *J. Mater. Process. Technol.* **2006**, *177*, 331–335. [[CrossRef](#)]
17. Raffaelli, R.; Mandolini, M.; Germani, M. Automation of flexible components virtual prototyping: Methodology, tools and validation. *J. Des. Res.* **2010**, *8*, 272–297. [[CrossRef](#)]
18. Jong, W.-R.; Ting, Y.-H.; Li, T.-C. Application of knowledge-based engineering for automated slide design. *Int. J. Adv. Manuf. Technol.* **2014**, *74*, 637–651. [[CrossRef](#)]
19. Gopinath, V.; Tarkian, M.; Ölvander, J.; Gaziza, W. Template driven conceptual design of high speed trains. In *Proceedings of the ASME International Design Engineering Technical Conference and Computers and Information in Engineering Conference, Buffalo, NY, USA, 17–20 August 2014*; Paper No: DETC2014-34045, V02AT03A050; American Society of Mechanical Engineers: New York, NY, USA, 2014; Volume 2A.
20. Zhang, X.; Thomson, V. Modelling the development of complex products using a knowledge perspective. *Res. Eng. Des.* **2019**, *30*, 203–226. [[CrossRef](#)]
21. Yu, C.; Zhang, F.-P.; Butt, S.I.; Yan, Y.; Lv, W. OntoIMM: An ontology for product intelligent master model. *Appl. Sci.* **2019**, *9*, 2553. [[CrossRef](#)]
22. Chapman, C.B.; Pinfold, M. The application of a knowledge based engineering approach to the rapid design and analysis of an automotive structure. *Adv. Eng. Softw.* **2001**, *32*, 903–912. [[CrossRef](#)]
23. Li, Z.; Zhou, X.; Wang, W.M.; Huang, G.; Tian, Z.; Huang, S. An ontology-based product design framework for manufacturability verification and knowledge reuse. *Int. J. Adv. Manuf. Technol.* **2018**, *99*, 2121–2135. [[CrossRef](#)]
24. González-Ciordia, B.; Fernández, B.; Artola, G.; Muro, M.; Sanz, Á.; de Lacalle, L.N.L. Failure-Analysis Based Redesign of Furnace Conveyor System Components: A Case Study. *Metals* **2019**, *9*, 816. [[CrossRef](#)]
25. Wang, G.; Hu, Y.; Tian, X.; Geng, J.; Hu, G.; Zhang, M. An integrated open approach to capturing systematic knowledge for manufacturing process innovation based on collective intelligence. *Appl. Sci.* **2018**, *8*, 340. [[CrossRef](#)]
26. Martínez-Costa, C.; Menárguez-Tortosa, M.; Fernández-Breis, J.T. Ontology-based Archetype Interoperability and Management. In *Proceedings of the First Spanish OpenHealth Symposium, Alcal de Henares, Spain, 29–30 April 2009*; pp. 22–27.
27. Chandu, K.M. Concurrent program archetypes. In *Proceedings of the Scalable Parallel Libraries Conference, Mississippi State, MS, USA, 12–14 October 1994*; pp. 1–9.
28. Eilouti, B.H. Design knowledge recycling using precedent-based analysis and synthesis models. *Des. Stud.* **2009**, *30*, 340–368. [[CrossRef](#)]
29. Ward, T. Design archetypes from group processes. *Des. Stud.* **1987**, *8*, 157–169. [[CrossRef](#)]
30. Xu, X.; Dong, P.; Liu, Y.; Zhang, H. Progress in Automotive Transmission Technology. *Automot. Innov.* **2018**, *1*, 187–210. [[CrossRef](#)]
31. Bansal, R.C.; Bhatti, T.S.; Kothari, D.P. On some of the design aspects of wind energy conversion systems. *Energy Convers. Manag.* **2002**, *43*, 2175–2187. [[CrossRef](#)]
32. Oliva, E.; Berselli, G.; Pini, F. Dynamic identification of industrial robots from low-sampled data. *Appl. Mech. Mater.* **2013**, *328*, 644–650. [[CrossRef](#)]
33. Leali, F.; Pellicciari, M.; Pini, F.; Vergnano, A.; Berselli, G. A calibration method for the integrated design of finishing robotic workcells in the aerospace industry. *Commun. Comput. Inf. Sci.* **2013**, *371*, 37–48.
34. Fuentes, A.; Nagamoto, H.; Litvin, F.L.; Gonzalez-Perez, I.; Hayasaka, K. Computerized design of modified helical gears finished by plunge shaving. *Comput. Methods Appl. Mech. Eng.* **2010**, *199*, 1677–1690. [[CrossRef](#)]
35. Álvarez, A.; Calleja, A.; Ortega, N.; de Lacalle, L.N.L. Five-Axis Milling of Large Spiral Bevel Gears: Toolpath Definition, Finishing, and Shape Errors. *Metals* **2018**, *8*, 353. [[CrossRef](#)]
36. Bo, P.; González, H.; Calleja, A.; de Lacalle, L.N.L.; Bartoň, M. 5-axis double-flank CNC machining of spiral bevel gears via custom-shaped milling tools—Part I: Modeling and simulation. *Precis. Eng.* **2020**, *62*, 204–212. [[CrossRef](#)]
37. Guo, H.; Gonzalez-Perez, I.; Fuentes-Aznar, A. Computerized generation and meshing simulation of face gear drives manufactured by circular cutters. *Mech. Mach. Theory* **2019**, *133*, 44–63. [[CrossRef](#)]

38. Jain, N.K.; Petare, A.C. Review of gear finishing processes. In *Comprehensive Materials Finishing*; Hashmi, M.S.J., Ed.; Elsevier: Oxford, UK, 2016; Volume 1, pp. 93–120.
39. Qin, Z.; Wu, Y.-T.; Lyu, S.-K. A Review of Recent Advances in Design Optimization of Gearbox. *Int. J. Precis. Eng. Manuf.* **2018**, *19*, 1753–1762. [[CrossRef](#)]
40. Gherardini, F.; Panari, D.; Leali, F. Identification of the main contributors in the 3D tolerances assessment in mechanical transmissions. In *Advances on Mechanics, Design Engineering and Manufacturing II. Lecture Notes in Mechanical Engineering*; Cavas-Martínez, F., Eynard, B., Fernández Cañavate, F., Fernández-Pacheco, D., Morer, P., Nigrelli, V., Eds.; Springer: Cham, Switzerland, 2019; pp. 152–161.
41. Fuentes-Aznar, A.; Gonzalez-Perez, I. Integrating non-contact metrology in the process of analysis and simulation of gear drives. Presented at the AGMA 2018 Fall Technical Meeting, Oakbrook, IL, USA, 24–26 September 2018; p. 18FTM21.
42. Studer, R.; Benjamins, V.R.; Fensel, D. Knowledge Engineering: Principles and methods. *Data Knowl. Eng.* **1998**, *25*, 161–197. [[CrossRef](#)]
43. La Rocca, G. Knowledge based engineering: Between AI and CAD. Review of a language based technology to support engineering design. *Adv. Eng. Inform.* **2012**, *26*, 159–179. [[CrossRef](#)]
44. Verhagen, W.J.C.; Bermell-Garcia, P.; Van Dijk, R.E.C.; Curran, R. A critical review of Knowledge-Based Engineering: An identification of research challenges. *Adv. Eng. Inform.* **2012**, *26*, 5–15. [[CrossRef](#)]
45. Fang, Y.; Liu, E.; Jin, J.; Gua, L. Domain knowledge driving in intelligent design of series mechanical product. In Proceedings of the 11th IEEE International Conference on Computer-Aided Design and Computer Graphics, Huangshan, China, 19–21 August 2009; pp. 422–428.
46. Leu, M.; Elmaraghy, H.; Nee, A.; Ong, S.K.; Lanzetta, M.; Putz, M.; Zhu, W.; Bernard, A. CAD model based virtual assembly simulation, planning and training. *CIRP Ann. Manuf. Technol.* **2013**, *62*, 799–822. [[CrossRef](#)]
47. Mansour, G.; Tsagaris, A.; Sagris, D. CNC machining optimization by genetic algorithms using CAD based system. *Int. J. Mod. Manuf. Technol.* **2013**, *5*, 75–80.
48. Vergnano, A.; Berselli, G.; Pellicciari, M. Parametric virtual concepts in the early design of mechanical systems: A case study application. *Int. J. Interact. Des. Manuf.* **2017**, *11*, 331–340. [[CrossRef](#)]
49. Gherardini, F.; Zardin, B.; Leali, F. A parametric CAD-based method for modelling and simulation of positive displacement machines. *J. Mech. Sci. Technol.* **2016**, *30*, 3253–3263. [[CrossRef](#)]
50. Zardin, B.; Borghi, M.; Gherardini, F.; Zanasi, N. Modelling and simulation of a hydrostatic steering system for agricultural tractors. *Energies* **2018**, *11*, 230. [[CrossRef](#)]
51. Neto, P.; Mendes, N. Direct off-line robot programming via a common CAD package. *Robot. Auton. Syst.* **2013**, *61*, 896–910. [[CrossRef](#)]
52. Rotondella, V.; Merulla, A.; Baldini, A.; Mantovani, S. Dynamic Modal Correlation of an Automotive Rear Subframe, with Particular Reference to the Modelling of Welded Joints. *Adv. Acoust. Vib.* **2017**, *2017*, 8572674. [[CrossRef](#)]
53. Goering, C.E.; Hansen, A.C. *Introduction. Chapter 1 in Engine and Tractor Power*, 4th ed.; ASAE: St. Joseph, MI, USA, 2004.
54. Peroni, M.; Vergnano, A.; Leali, F.; Brentegani, A. Design Archetype of Gears for Knowledge Based Engineering. In *Advances on Mechanics, Design Engineering and Manufacturing*; Springer: Cham, Switzerland, 2017; pp. 1131–1140.
55. Jansson, D.G.; Smith, S.M. Design fixation. *Des. Stud.* **1991**, *12*, 3–11. [[CrossRef](#)]
56. Chakrabarti, A.; Bligh, T.P. A scheme for functional reasoning in conceptual design. *Des. Stud.* **2001**, *22*, 493–517. [[CrossRef](#)]
57. Fiorineschi, L.; Rotini, F.; Rissone, P. A new conceptual design approach for overcoming the flaws of functional decomposition and morphology. *J. Eng. Des.* **2016**, *27*, 438–468. [[CrossRef](#)]
58. Robertson, B.F.; Radcliffe, D.F. Impact of CAD tools on creative problem solving in engineering design. *Comput. Aided Des.* **2009**, *41*, 136–146. [[CrossRef](#)]
59. Gofman, A.; Moskowitz, H. Steps towards a consumer-driven innovation machine for ‘ordinary’ product categories in their later lifecycle stages. *Int. J. Technol. Manag.* **2009**, *45*, 349–363. [[CrossRef](#)]

