

This is a pre print version of the following article:

A geometric statement of the Harnack inequality for a degenerate Kolmogorov equation with rough coefficients / Anceschi, Francesca; Eleuteri, Michela; Polidoro, Sergio. - In: COMMUNICATIONS IN CONTEMPORARY MATHEMATICS. - ISSN 0219-1997. - 21:7(2019), pp. 1-17.  
[10.1142/S0219199718500578]

*Terms of use:*

The terms and conditions for the reuse of this version of the manuscript are specified in the publishing policy. For all terms of use and more information see the publisher's website.

27/07/2024 15:27

# A geometric statement of the Harnack inequality for a degenerate Kolmogorov equation with rough coefficients

FRANCESCA ANCESCHI \*MICHELA ELEUTERI †SERGIO POLIDORO ‡

January 9, 2018

## Abstract

We consider weak solutions of second order partial differential equations of Kolmogorov-Fokker-Planck type with measurable coefficients in the form

$$\partial_t u + \langle v, \nabla_x u \rangle = \operatorname{div}_v (A(v, x, t) \nabla_v u) + \langle b(v, x, t), \nabla_v u \rangle + f, \quad (v, x, t) \in \mathbb{R}^{2n+1},$$

where  $A$  is an uniformly positive symmetric matrix with bounded measurable coefficients,  $f$  and the components of the vector  $b$  are bounded and measurable functions. We give a geometric statement of the Harnack inequality recently proven by Golse, Imbert, Mouhot and Vasseur. As a corollary we obtain a strong maximum principle.

## 1 Introduction

We consider second order partial differential equations of Kolmogorov-Fokker-Planck type in the form

$$\begin{aligned} \partial_t u(v, x, t) + \sum_{j=1}^n v_j \partial_{x_j} u(v, x, t) &= \sum_{j,k=1}^n \partial_{v_j} (a_{jk}(v, x, t) \partial_{v_k} u(v, x, t)) \\ &+ \sum_{j=1}^n b_j(v, x, t) \partial_{v_j} u(v, x, t) + f(v, x, t), \quad (v, x, t) \in \Omega, \end{aligned} \tag{1.1}$$

where:

*i)*  $\Omega$  is an open subset of  $\mathbb{R}^{2n+1}$ ;

*ii)*  $A = (a_{jk})_{j,k=1,\dots,n}$  is a symmetric matrix with real measurable entries. Moreover, there exist two positive constants  $\lambda, \Lambda$  such that

$$\lambda |\xi|^2 \leq \langle A(v, x, t) \xi, \xi \rangle \leq \Lambda |\xi|^2, \quad \forall (v, x, t) \in \Omega, \quad \forall \xi \in \mathbb{R}^n;$$

---

\*Dipartimento di Scienze Fisiche, Informatiche e Matematiche, Università di Modena e Reggio Emilia, Via Campi 213/b, 41125 Modena (Italy). E-mail: francesca.anceschi@unimore.it

†Dipartimento di Scienze Fisiche, Informatiche e Matematiche, Università di Modena e Reggio Emilia, Via Campi 213/b, 41125 Modena (Italy). E-mail: michela.eleuteri@unimore.it

‡Dipartimento di Scienze Fisiche, Informatiche e Matematiche, Università di Modena e Reggio Emilia, Via Campi 213/b, 41125 Modena (Italy). E-mail: sergio.polidoro@unimore.it

iii)  $b = (b_1, \dots, b_n)$  is a vector of  $\mathbb{R}^n$  with bounded measurable coefficients;

iv)  $f \in L^\infty(\Omega)$ .

As the coefficients of the operator  $\mathcal{L}$  are measurable, we need to consider *weak solutions* of  $\mathcal{L}u = f$  in the following sense. Consider any open subset  $\Omega$  of  $\mathbb{R}^{2n+1}$ . A weak solution to (1.1) is a function  $u \in L^2_{\text{loc}}(\Omega)$  such that  $\partial_{v_1}u, \dots, \partial_{v_n}u$  and the directional derivative  $\partial_t u + \langle v, \nabla_x u \rangle$  belong to  $L^2_{\text{loc}}(\Omega)$ , and moreover

$$\int_{\Omega} (\partial_t u + \langle v, \nabla_x u \rangle - \langle b, \nabla_v u \rangle) \varphi \, dv \, dx \, dt + \int_{\Omega} \langle A \nabla_v u, \nabla_v \varphi \rangle \, dv \, dx \, dt = \int_{\Omega} f \varphi \, dv \, dx \, dt,$$

for every  $\forall \varphi \in C_0^\infty(\Omega)$ . In the sequel of this note the equation (1.1) will be understood in the weak sense and will be written in the short form,  $\mathcal{L}u = f$ , where

$$\mathcal{L}u := \partial_t u + \langle v, \nabla_x u \rangle - \text{div}_v(A \nabla_v u) - \langle b, \nabla_v u \rangle, \quad (v, x, t) \in \Omega. \quad (1.2)$$

The motivation for studying equation (1.2) comes from the Stochastic theory and from its applications to several research fields. Indeed, the operator  $\mathcal{L}_0$  defined as

$$\mathcal{L}_0 u := \partial_t u + \langle v, \nabla_x u \rangle - \frac{1}{2} \text{div}_v(\nabla_v u), \quad (1.3)$$

was considered by Kolmogorov in [23] to describe the probability density of a system with  $2n$  degrees of freedom. Precisely, the fundamental solution  $\Gamma = \Gamma(v, x, t; v_0, x_0, t_0)$  of (1.3) is the density of the stochastic process

$$\begin{cases} V_t = v_0 + W_{t-t_0}, \\ X_t = x_0 + \int_{t_0}^t V_s \, ds, \quad t > t_0, \end{cases} \quad (1.4)$$

which is a solution to the Langevin equation  $dV_t = dW_t, dX_t = V_t dt$ . Here  $(W_t)_{t>0}$  denotes a Wiener process. Note that  $\mathcal{L}_0$  is a particular case of the differential operator appearing in (1.2), as we choose  $A$  equal to the  $n \times n$  identity matrix  $I_n$ , multiplied by  $\frac{1}{2}$ , and  $b = 0$ .

Other applications of the operator in (1.3) arise in the kinetic theory of gases. In this setting  $\mathcal{L}$  takes the following general form

$$Y u = \mathcal{Q}[u], \quad (1.5)$$

where  $Y$  denotes the *total derivative* with respect to the time in the phase space  $(v, x) \in \mathbb{R}^n \times \mathbb{R}^n$

$$Y u := \partial_t u + \langle v, \nabla_x u \rangle, \quad (1.6)$$

while  $\mathcal{Q}$  is a collision operator, which can occur in the form of a second order differential operator, acting on the velocity variable  $v$ , that can appear either in linear or in nonlinear form. In the Fokker-Planck-Landau model  $\mathcal{Q}$  depends on the variable  $v$  and on the unknown solution  $u$  through some integral expressions. For the description of the stochastic processes and kinetic models leading to equations of the type (1.2), we refer to the classical monographs [7], [16] and [8].

We also mention that equations similar to (1.2) appear in Finance. For instance the equation

$$\partial_t + \frac{1}{2} \sigma^2 S^2 \partial_S^2 V + S \partial_A V + r(S \partial_S V - V) = 0 \quad (1.7)$$

occurs in the Black & Scholes framework when considering the problem of pricing Asian options. We refer to [1, 3, 4], and [34] for a more detailed discussion of this topic.

The main theoretical interest in the operator  $\mathcal{L}_0$  relies on its regularity properties, first noticed by Kolmogorov. Indeed, Kolmogorov writes in [23] the explicit expression of the fundamental solution  $\Gamma$  of (1.3), and points out the remarkable fact that it is a  $C^\infty$  smooth function, despite the strong degeneracy of its characteristic form. Later, Hörmander in [20] considers  $\mathcal{L}_0$  as the prototype of a wide family of *degenerate hypoelliptic operators*, with the following meaning.

Let  $\Omega$  be an open subset of  $\mathbb{R}^{2n+1}$ . We say that  $\mathcal{L}_0$  is HYPOELLIPTIC in  $\Omega$  if, for every measurable function  $u : \Omega \rightarrow \mathbb{R}$  which solves the equation  $\mathcal{L}_0 u = f$  in the distributional sense, we have

$$f \in C^\infty(\Omega) \quad \Rightarrow \quad u \in C^\infty(\Omega). \quad (1.8)$$

In Section 2 we recall some known results about  $\mathcal{L}_0$  and about more general linear second order differential operators, that in the sequel will be denoted by  $K_0$  (see (2.1) below), satisfying the Hörmander's hypoellipticity condition introduced in [20]. Since the works by Folland [18], Rothschild and Stein [38], Nagel, Stein and Wainger [33] concerning operators satisfying the Hörmander's condition, it is known that the natural framework for the regularity of that operators is the analysis on Lie groups. The first study of the *non-Euclidean* translation group related to the degenerate Kolmogorov operators  $K_0$  has been performed by Lanconelli and one of the authors in [26]. This non-commutative structure underlying  $\mathcal{L}_0$  has replaced the usual *Euclidean translations* and the *parabolic dilations* in the study of operators  $\mathcal{L}$  with variable coefficients  $a_{jk}$ 's and  $b_j$ 's. The development of the regularity theory for operators  $\mathcal{L}$  has been achieved in several steps, paralleling the history of the uniformly parabolic equations.

In particular, several interesting results have been obtained as the definition of *Hölder continuous functions* is given in terms of the Lie group relevant to  $\mathcal{L}_0$ . We refer to Weber [42], Il'in [21], Eidelman et al. [17], Polidoro [36], Delarue and Menozzi [13] for the construction of a fundamental solution based on the *parametrix method*. We quote [36], [37] for the proof of the upper and lower bounds for the fundamental solution, of mean value formulas and Harnack inequalities for the non-negative solutions  $u$  of  $\mathcal{L}u = 0$ . Schauder type estimates have been proved by Satyro [39], Lunardi [28], Manfredini [29]. Analogous results have been proven in a more general context by Morbidelli [30], Di Francesco and Pascucci [14], and Di Francesco and Polidoro [15].

The study of the operator  $\mathcal{L}$  with *measurable coefficients* has required some tools for the construction of a functional analysis on the Lie group relevant to  $\mathcal{L}_0$ . In the work by Pascucci and Polidoro [35], the classical iterative method introduced by Moser ([31], [32]), which in turn relies on the combination of a Caccioppoli inequality with a Sobolev inequality, have been used to obtain a  $L^\infty$  upper bound for the weak solutions of  $\mathcal{L}u = 0$ . The Sobolev inequality has been obtained in [35] by using the fundamental solution  $\Gamma$  of  $\mathcal{L}_0$  and its invariance with respect to the Lie group related to  $\mathcal{L}_0$ . The methods and the results of [35] have been then extended to Kolmogorov type operators on non-homogeneous Lie groups by Cinti, Pascucci and Polidoro [11]; we also recall [12] and [24] where similar techniques have been adapted to the non-Euclidean setting to prove  $L^\infty$  local estimates for the solutions.

A further important step in the functional analysis for operators  $\mathcal{L}$  and for its regularity theory has been done by Wang and Zhang [40, 41], who have proven a weak form of the Poincaré

inequality and the Hölder continuity of the weak solutions  $u$  of  $\mathcal{L}u = 0$ . More recently, Golse, Imbert, Mouhot and Vasseur [19] provide us with an alternative proof of the Hölder continuity of the solutions and prove an invariant Harnack inequality for the positive solutions of  $\mathcal{L}u = 0$ . Based on the Harnack inequality of [19], Lanconelli, Pascucci and Polidoro prove in [25] Gaussian upper and lower bounds for the fundamental solution of  $\mathcal{L}$  (see also [24]).

In this note we prove a geometric version of the Harnack inequality proved in [19], whose statement is recalled in Theorem 3.1 below, after some preliminary notation. In the unit box of  $\mathbb{R}^{2n+1}$ :

$$Q = ]-1, 1[^n \times ]-1, 1[^n \times ]-1, 0[, \quad (1.9)$$

it reads as the usual parabolic Harnack inequality: there exist two *small* boxes  $Q^+$  and  $Q^-$  contained in  $Q$ , with  $Q^+$  located *above*  $Q^-$  with respect to the time variable, and a positive constant  $M$ , such that

$$\sup_{Q^-} u \leq M(\inf_{Q^+} u + \|f\|_{L^\infty(Q)})$$

for every non-negative solution  $u$  of  $\mathcal{L}u = f$  in  $Q$ , with  $f \in L^\infty(Q)$ .

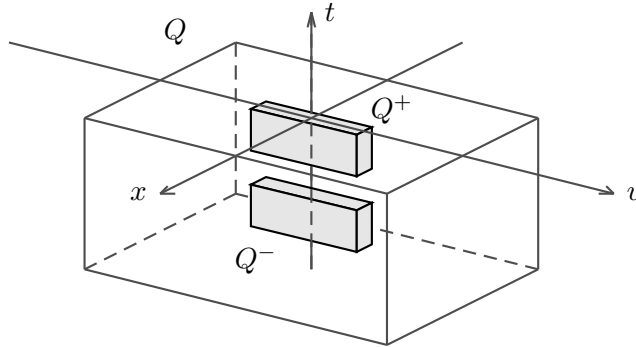

FIG. 1 - HARNACK INEQUALITY.

We recall that, in the classical statement of the Harnack inequality for uniformly parabolic operators with measurable coefficients, the size of the boxes  $Q^+$  and  $Q^-$ , and the gap between the lower basis of  $Q^+$  and upper basis of  $Q^-$  can be arbitrarily chosen (see Theorem of [31]). On the contrary, in the statement of the Harnack inequality for the operator  $\mathcal{L}$  given in [19], neither the size of the boxes  $Q^+$  and  $Q^-$ , nor their *position* in  $Q$  is characterized. Actually, as we will see in the sequel, it is known that the Harnack inequality does not hold for any choice of the boxes  $Q^+$  and  $Q^-$ . This fact was previously noticed by Cinti, Nyström and Polidoro in [10], where classical solutions of  $\mathcal{L}_0u = 0$  are considered, and by Kogoj and Polidoro in [22]. We give here a sufficient condition for the validity of the Harnack inequality. For its precise statement we refer to the notion of *attainable set*  $\mathcal{A}_{(v_0, x_0, t_0)}$  given in Definition 2.2 below. In the sequel  $\text{int}(\mathcal{A}_{(v_0, x_0, t_0)})$  denotes the interior of  $\mathcal{A}_{(v_0, x_0, t_0)}$ .

**Theorem 1.1** *Let  $\Omega$  be an open subset of  $\mathbb{R}^{2n+1}$  and let  $f \in L^\infty(\Omega)$ . For every  $(v_0, x_0, t_0) \in \Omega$ , and for any compact set  $K \subseteq \text{int}(\mathcal{A}_{(v_0, x_0, t_0)})$ , there exists a positive constant  $C_K$ , only dependent on  $\Omega$ ,  $(v_0, x_0, t_0)$ ,  $K$  and on the operator  $\mathcal{L}$ , such that*

$$\sup_K u \leq C_K (u(v_0, x_0, t_0) + \|f\|_{L^\infty(\Omega)}),$$

for every non-negative solution to  $\mathcal{L}u = f$ .

We note that any weak solution  $u$  of  $\mathcal{L}u = f$  is Hölder continuous (see [40, 41] for the equation  $\mathcal{L}u = 0$ , and Theorem 2 in [19] for  $\mathcal{L}u = f$  with  $f \in L^\infty$ ), then  $u(v_0, x_0, t_0)$  is well defined. As we will see in the Definition 2.2, the attainable set  $\mathcal{A}_{(v_0, x_0, t_0)}$  depends on the geometry of  $\Omega$ , and it can be easily described. For instance, when it agrees with the unit box  $Q$  in (1.9) we have that

$$\mathcal{A}_{(0,0,0)} = \{(v, x, t) \in Q \mid |x_j| \leq |t|, j = 1, \dots, n\}. \quad (1.10)$$

The proof of this fact can be seen in [10], Proposition 4.5, p.353.

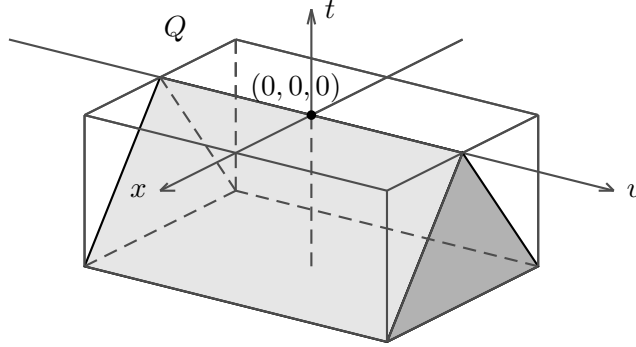

FIG. 2 -  $\mathcal{A}_{(0,0,0)}(Q)$ .

A direct consequence of our main result inequality is the following strong maximum principle.

**Theorem 1.2** *Let  $\Omega$  be an open subset of  $\mathbb{R}^{2n+1}$ , and let  $u$  be a non-negative solution to  $\mathcal{L}u = 0$ . If  $u(v_0, x_0, t_0) = 0$  for some  $(v_0, x_0, t_0) \in \Omega$ , then  $u(v, x, t) = 0$  for every  $(v, x, t) \in \overline{\mathcal{A}_{(v_0, x_0, t_0)}}$ .*

Note that the Theorem 1.2 extends to weak solution to  $\mathcal{L}u = 0$  the well known Bony's strong maximum principle [5] for classical solutions of degenerate hypoelliptic Partial Differential Equations with smooth coefficients. We also recall the work of Amano [2], where differential operators with continuous coefficients are considered.

We also note that the Theorem 1.2 is somehow optimal. Indeed, in Proposition 4.5 of [10] it is shown that there exists a non-negative solution  $u$  to  $\mathcal{L}_0 u = 0$  in  $Q$  such that  $u(v, x, t) = 0$  for every  $(v, x, t) \in \overline{\mathcal{A}_{(0,0,0)}}$ , and  $u(v, x, t) > 0$  for every  $(v, x, t) \in Q \setminus \overline{\mathcal{A}_{(0,0,0)}}$ .

This article is organized as follows. Section 2 contains some preliminary results and known facts about the regularity properties of the operator  $\mathcal{L}_0$  and on its invariance with respect to a non-Euclidean group structure on  $\mathbb{R}^{2n+1}$ . It also contains a short discussion of the controllability problem related to  $\mathcal{L}_0$  and the Definition of the Attainable set. In Section 3 we recall the Harnack inequality given in [19] and we prove a dilation-invariant version of it. In Section 4 we prove our main results.

## 2 Preliminaries

In this Section we recall some known facts on the equation (1.2), and on its prototype (1.3), that will play an important role in our study. We first recall that (1.3) belongs to the more general class of differential operators considered in [26]. Specifically, in [26] have been studied operators in the following form

$$K_0 u := \sum_{i,j=1}^N a_{i,j} \partial_{y_i y_j} u + \sum_{i,j=1}^N b_{i,j} y_j \partial_{y_i} u + \partial_t u, \quad (y, t) \in \mathbb{R}^{N+1}, \quad (2.1)$$

where  $\tilde{A} = (a_{i,j})_{i,j=1,\dots,N}$  and  $B = (b_{i,j})_{i,j=1,\dots,N}$  are constant matrices, with  $\tilde{A}$  symmetric and non-negative. We can choose, as it is not restrictive, a basis of  $\mathbb{R}^N$  such that  $\tilde{A}$  takes the following form

$$\tilde{A} = \begin{pmatrix} A & 0 \\ 0 & 0 \end{pmatrix},$$

with the constant matrix  $A = (a_{i,j})_{i,j=1,\dots,m_0}$  strictly positive.

Clearly, as  $m_0 < N$  the operator  $K_0$  is strongly degenerate. The regularity properties of  $K_0$  depend on its first order part

$$Y = \langle B y, \nabla \rangle + \partial_t. \quad (2.2)$$

In order to clarify this assertion, we introduce some further notation. Let  $C = (c_{i,j})_{i,j=1,\dots,N}$  denote the *square root* of  $\tilde{A}$ , that is the unique positive symmetric matrix such that  $C^2 = \tilde{A}$ . Then  $K_0$  can be written as

$$K_0 = \sum_{j=1}^{m_0} X_j^2 + Y, \quad (2.3)$$

with

$$X_i = \sum_{j=1}^N c_{ij} \partial_{y_j}, \quad i = 1, \dots, m_0. \quad (2.4)$$

With the above notation, the following statements are equivalent:

( $H_1$ ) there exists a basis of  $\mathbb{R}^N$  such that  $B$  has the form

$$\begin{pmatrix} * & * & \dots & * & * \\ B_1 & * & \dots & * & * \\ 0 & B_2 & \dots & * & * \\ \vdots & \vdots & \ddots & \vdots & \vdots \\ 0 & 0 & \dots & B_\kappa & * \end{pmatrix}, \quad (2.5)$$

where  $B_j$  is a matrix  $m_j \times m_{j-1}$  of rank  $m_j$ , with

$$m_0 \geq m_1 \geq \dots \geq m_\kappa \geq 1, \quad m_0 + m_1 + \dots + m_\kappa = N,$$

while  $*$  are constant and arbitrary blocks;

( $H_2$ ) Hörmander's condition:

$$\text{rank Lie}(X_1, \dots, X_{m_0}, Y) = N + 1, \quad \text{at every point of } \mathbb{R}^{N+1}; \quad (2.6)$$

( $H_3$ ) Kalman's controllability condition:

$$\text{rank}(C, BC, \dots, B^{N-1}C) = N, \quad (2.7)$$

(see [27], Theorem 5, p. 81).

For the equivalence of the above conditions we refer to [26]. In the sequel, we assume that the basis of  $\mathbb{R}^N$  is as in ( $H_1$ ).

We note that the regularity properties of the differential operator  $K_0$  are related to some differential properties of the vector fields  $X_1, \dots, X_{m_0}, Y$ . As we said in the Introduction, this fact was the starting point of the regularity theory for degenerate Hörmander operators developed in [20, 18, 38, 33]. For this reason we will recall some basic facts about the Lie groups related to  $K_0$ .

It is known that every operator  $K_0$  is invariant with respect to a *non-Euclidean* translation defined as follows. For every  $(y_0, t_0), (y, t) \in \mathbb{R}^{N+1}$  we set

$$(y_0, t_0) \circ (y, t) := (y + \exp(tB)y_0, t + t_0). \quad (2.8)$$

If  $u$  is a solution of the equation  $K_0 u = f$  in some open set  $\Omega \subset \mathbb{R}^{N+1}$ , then the function  $v(y, t) := u((y_0, t_0) \circ (y, t))$  is solution to  $K_0 v = g$ , where  $g(y, t) := f((y_0, t_0) \circ (y, t))$  in the set  $\{(y, t) \in \mathbb{R}^{N+1} \mid (y_0, t_0) \circ (y, t) \in \Omega\}$ . It is known that  $\mathbb{R}^{N+1}$  with the operation “ $\circ$ ” is a non commutative group, with identity  $(0, 0)$ . The inverse of  $(y, t)$  is

$$(y, t)^{-1} = (-\exp(-tB)y, -t). \quad (2.9)$$

Moreover, if (and only if) all the  $*$ -block in (2.5) are null, then  $K_0$  is homogeneous of degree two with respect to the family of the following dilatations,

$$d_r := \text{diag}(rI_{m_0}, r^3I_{m_1}, \dots, r^{2\kappa+1}I_{m_\kappa}, r^2), \quad (2.10)$$

( $I_{m_j}$  denotes the  $m_j \times m_j$  identity matrix). In this case the following *distributive property* of the dilation holds

$$(d_r(y_0, t_0)) \circ (d_r(y, t)) = d_r((y_0, t_0) \circ (y, t)),$$

for every  $(y_0, t_0), (y, t) \in \mathbb{R}^{N+1}$  and for every  $r > 0$ . In literature the structure

$$\mathbb{L} := (\mathbb{R}^{N+1}, \circ, (d_r)_{r>0}), \quad (2.11)$$

is usually referred to as *homogeneous Lie group*. We quote [26] for the main properties of the Lie group  $\mathbb{L}$  defined by (2.8), (2.10).



We now introduce some basic notions of the Control Theory in order to describe the set where the Harnack inequality holds for the non-negative solutions of  $\mathcal{L}u = f$ . As noticed above, the link between the Regularity Theory for linear PDEs and the Control Theory is not surprising, as the hypoellipticity of  $K_0$  is equivalent to the controllability condition  $(H_3)$ . The first notion we need is the  $\mathcal{L}$ -ADMISSIBLE CURVE, the second one is that of ATTAINABLE SET. For the precise statement of them we first consider the operator  $K_0$  in (2.1) and we recall the relevant notation (2.3). We say that a curve  $\gamma : [0, T] \rightarrow \mathbb{R}^{N+1}$  is  $K_0$ -ADMISSIBLE if:

- it is absolutely continuous;
- $\dot{\gamma}(s) = \sum_{k=1}^{m_0} \omega_k(s) X_k(\gamma(s)) + Y(\gamma(s))$  a.e. in  $[0, T]$ , with  $\omega_1, \omega_2, \dots, \omega_{m_0} \in L^1[0, T]$ .

Moreover we say that  $\gamma$  steers  $(y_0, t_0)$  to  $(y, t)$ , for  $t_0 > t$ , if  $\gamma(0) = (y_0, t_0)$  and  $\gamma(T) = (y, t)$ . Note that  $t(s) = t_0 - s$ , then  $T = t_0 - t$  and  $t_0 > t$ . We denote by  $\mathcal{A}_{(y_0, t_0)}(\Omega)$  the following set:

$$\mathcal{A}_{(y_0, t_0)}(\Omega) = \left\{ (y, t) \in \Omega \mid \begin{array}{l} \text{there exists a } K_0 \text{ - admissible curve } \gamma : [0, T] \rightarrow \Omega \\ \text{such that } \gamma(0) = (y_0, t_0) \text{ and } \gamma(T) = (y, t). \end{array} \right\}.$$

We will refer to  $\mathcal{A}_{(y_0, t_0)}(\Omega)$  as ATTAINABLE SET.

In the sequel of this Section we focus on the equation (1.3), which writes in the form (2.1) if we choose  $N = 2n, y = (v, x)$ ,

$$A = I_n, \quad \text{and} \quad B = \begin{pmatrix} 0_n & 0_n \\ I_n & 0_n \end{pmatrix}.$$

Here  $0_n$  and  $I_n$  denote the zero and the identity  $n \times n$  matrices, respectively. In particular,  $\mathcal{L}_0$  satisfies the condition  $(H_1)$  and is invariant with respect to a dilation of the form (2.10). Moreover, if we identify any vector field  $X = \sum_{j=1}^{2n} c_j \partial_{y_j}$  with the vector  $\sum_{j=1}^{2n} c_j e_j$ , being  $e_j$  the the  $j^{\text{th}}$  vector of the canonical basis of  $\mathbb{R}^N$ , then  $\mathcal{L}_0$  writes in the form (2.3) provided that we set

$$Y = \langle v, \nabla_x \rangle + \partial_t \sim \begin{pmatrix} 0 \\ \vdots \\ 0 \\ v_1 \\ \vdots \\ v_n \\ 1 \end{pmatrix}, \quad X_j = \partial_{v_j} \sim e_j = \begin{pmatrix} 0 \\ \vdots \\ 1 \\ 0 \\ \vdots \\ 0 \end{pmatrix} \leftarrow j^{\text{th}} \quad \text{for } j = 1, \dots, n.$$

In this setting the Lie group  $\mathbb{L}$  in (2.11) is defined in terms of the following *Galilean change of coordinate* in the Phase Space,

$$(v_0, x_0, t_0) \circ (v, x, t) := (v + v_0, x_0 + x + tv_0, t_0 + t), \quad (v_0, x_0, t_0), (v, x, t) \in \mathbb{R}^{2n+1}. \quad (2.12)$$

Moreover,  $\mathcal{L}_0$  is invariant with respect to the following

$$d_r(v, x, t) = (rv, r^3x, r^2t), \quad (v, x, t) \in \mathbb{R}^{2n+1}, r > 0. \quad (2.13)$$

In the sequel we will denote by  $\mathbb{G}$  the group defined in terms of (2.12) and (2.13)

$$\mathbb{G} := (\mathbb{R}^{2n+1}, \circ, (d_r)_{r>0}), \quad (2.14)$$

When we consider the operator  $K_0 = \mathcal{L}_0$ , the  $K_0$ -admissible curves can be easily described. Indeed, if we denote

$$\gamma(s) = (v(s), x(s), t(s)), \quad s \in [0, T],$$

then the problem

$$\dot{\gamma}(s) = \sum_{k=1}^{m_0} \omega_k(s) X_k(\gamma(s)) + Y(\gamma(s)), \quad \gamma(0) = (y, t), \quad \gamma(T) = (\eta, \tau),$$

becomes

$$\dot{v}(s) = \omega(s), \quad \dot{x}(s) = v(s), \quad \dot{t}(s) = -1, \quad (2.15)$$

and its solution is

$$v(s) = v_0 + \int_0^s \omega(\tau) d\tau, \quad x(s) = x_0 + \int_0^s v(\tau) d\tau, \quad t(s) = t_0 - s,$$

The controllability condition  $(H_3)$  guarantees that, for every  $(v, x, t) \in \mathbb{R}^{2n+1}$ , with  $t < t_0$ , there is at least a *control*  $\omega = (\omega_1, \omega_2, \dots, \omega_n) \in (\mathcal{L}^1[0, T])^n$  such that the solution to (2.15) satisfies  $(v(T), x(T), t(T)) = (v, x, t)$ . In the sequel we will use the following notation

**Definition 2.1** A curve  $\gamma = (v, x, t) : [0, T] \rightarrow \mathbb{R}^{2n+1}$  is said to be  $\mathcal{L}$ -ADMISSIBLE if it is absolutely continuous, and solves the equation (2.15) for almost every  $s \in [0, T]$ , with  $\omega_1, \omega_2, \dots, \omega_n \in L^1[0, T]$ . Moreover we say that  $\gamma$  steers  $(v_0, x_0, t_0)$  to  $(v, x, t)$ , with  $t_0 > t$ , if  $\gamma(0) = (v_0, x_0, t_0)$  and  $\gamma(T) = (v, x, t)$ .

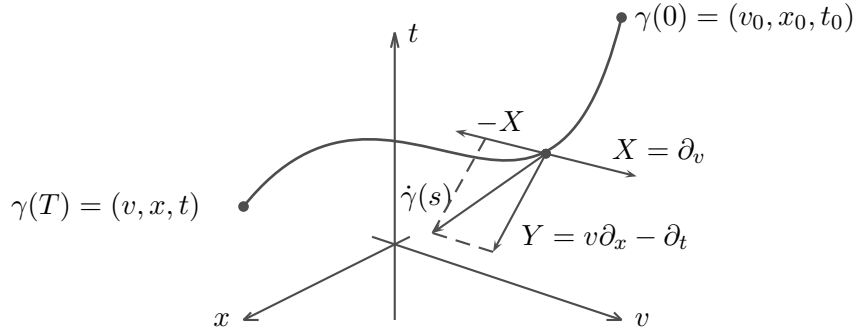

FIG. 3 - AN  $\mathcal{L}$ -ADMISSIBLE CURVE STEERING  $(v_0, x_0, t_0)$  TO  $(v, x, t)$ .

**Definition 2.2** Let  $\Omega$  be any open subset of  $\mathbb{R}^{2n+1}$ , and let  $(v_0, x_0, t_0) \in \Omega$ . We denote by  $\mathcal{A}_{(v_0, x_0, t_0)}(\Omega)$  the following set:

$$\mathcal{A}_{(v_0, x_0, t_0)}(\Omega) = \left\{ (v, x, t) \in \Omega \mid \text{there exists an } \mathcal{L} \text{ - admissible curve } \gamma : [0, T] \rightarrow \Omega \right. \\ \left. \text{such that } \gamma(0) = (v_0, x_0, t_0) \text{ and } \gamma(T) = (v, x, t). \right\}.$$

We will refer to  $\mathcal{A}_{(v_0, x_0, t_0)}(\Omega)$  as ATTAINABLE SET. We will use the notation  $\mathcal{A}_{(v_0, x_0, t_0)} = \mathcal{A}_{(v_0, x_0, t_0)}(\Omega)$  whenever there is no ambiguity on the choice of the set  $\Omega$ .

### 3 Harnack inequalities

In this Section we recall the Harnack inequality for equation  $\mathcal{L}u = f$  due to Golse, Imbert, Mouhot and Vasseur (see Theorem 3 in [19]), then we prove some preliminary results useful for the proof of our Theorem 1.1.

Let  $Q = ]-1, 1[^{2n} \times ]-1, 0[$  be the *unit box* introduced in (1.9). Based on the dilation (2.13) and on the Galilean translation (2.12), for every positive  $r$  and for every  $(v_0, x_0, t_0)$  we define the sets

$$\begin{aligned} Q_r &:= d_r Q = \{d_r(v, x, t) \mid (v, x, t) \in Q\}, \\ Q_r(v_0, x_0, t_0) &:= (v_0, x_0, t_0) \circ d_r Q = \\ &\quad \{(v_0, x_0, t_0) \circ d_r(v, x, t) \mid (v, x, t) \in Q\}. \end{aligned}$$

A direct computation shows that

$$\begin{aligned} Q_r &= ]-r, r[^{n} \times ]-r^3, r^3[^{n} \times ]-r^2, 0[, \\ Q_r(v_0, x_0, t_0) &= \left\{ (v, x, t) \in \mathbb{R}^{2n+1} \mid \begin{aligned} &|(v - v_0)_j| < r, \\ &|(x - x_0 - (t - t_0)v_0)_j| < r^3, j = 1, \dots, n, \\ &t_0 - r^2 < t < t_0 \end{aligned} \right\}. \end{aligned}$$

With the above notation, the following result holds.

**Theorem 3.1** (Theorem 2 in [19]) *There exist three constants  $M > 1, R > 0, \Delta > 0$ , with  $0 < R^2 < \Delta < \Delta + R^2 < 1$ , such that*

$$\sup_{Q^-} u \leq M(\inf_{Q^+} u + \|f\|_{L^\infty(Q)})$$

for every non-negative weak solution  $u$  to the equation  $\mathcal{L}u = f$  on  $Q$ , with  $f \in L^\infty(Q)$ . The constants  $M, R$  and  $\Delta$  only depend on the dimension  $n$  and on the ellipticity constants  $\lambda$  and  $\Lambda$ . Moreover  $Q^+, Q^-$  are defined as follows

$$Q^+ = Q_R \text{ with } 0 < R^2 < \Delta < \Delta + R^2 < 1, \quad Q^- = Q_R(0, 0, -\Delta).$$

As Golse, Imbert, Mouhot and Vasseur notice in Remark 4 in [19], “using the transformation (2.12), we get a Harnack inequality for cylinders centered at an arbitrary point  $(v_0, x_0, t_0)$ ”. We next give a precise meaning to this assertion and we improve it by also using the dilation (2.13).

**Theorem 3.2** *Let  $(v_0, x_0, t_0)$  be any point of  $\mathbb{R}^{2n+1}$  and let  $r$  be a positive number. There exist three constants  $M > 1, R > 0, \Delta > 0$ , with  $0 < R^2 < \Delta < \Delta + R^2 < 1$ , such that*

$$\sup_{Q_r^-(v_0, x_0, t_0)} u \leq M\left(\inf_{Q_r^+(v_0, x_0, t_0)} u + \|f\|_{L^\infty(Q_r(v_0, x_0, t_0))}\right)$$

for every non-negative weak solution  $u$  to the equation  $\mathcal{L}u = f$  on  $Q_r(v_0, x_0, t_0)$ , with  $f \in L^\infty(Q_r(v_0, x_0, t_0))$ . The constants  $M, R$  and  $\Delta$  only depend on the dimension  $n$  and on the ellipticity constants  $\lambda$  and  $\Lambda$ . Moreover  $Q_r^+(v_0, x_0, t_0), Q_r^-(v_0, x_0, t_0)$  are defined as follows

$$Q_r^+(v_0, x_0, t_0) = (v_0, x_0, t_0) \circ d_r Q^+, \quad Q_r^-(v_0, x_0, t_0) = (v_0, x_0, t_0) \circ d_r Q^-.$$

PROOF. We rely on the invariance of the operator  $\mathcal{L}_0$  with respect to the group (2.14). If  $u$  is a non-negative solution to  $\mathcal{L}u = f$  in  $Q_r(v_0, x_0, t_0)$ , then the function  $\tilde{u}(v, x, t) := u(d_{1/r}((v_0, x_0, t_0)^{-1} \circ (v, x, t)))$  is a solution in the unit box  $Q$  to the following equation

$$\tilde{\mathcal{L}}\tilde{u} =: \partial_t \tilde{u} + \langle v, \nabla_x \tilde{u} \rangle - \operatorname{div}_v(\tilde{A} \nabla_v \tilde{u}) - \langle \tilde{b}, \nabla_v \tilde{u} \rangle = \tilde{f}.$$

Here  $\tilde{A}(v, x, t) := A(d_{1/r}((v_0, x_0, t_0)^{-1} \circ (v, x, t)))$ ,  $\tilde{b}(v, x, t) := b(d_{1/r}((v_0, x_0, t_0)^{-1} \circ (v, x, t)))$  and  $\tilde{f}(v, x, t) := f(d_{1/r}((v_0, x_0, t_0)^{-1} \circ (v, x, t)))$ . Moreover  $(v_0, x_0, t_0)^{-1}$  is defined in (2.9). Even though  $\tilde{\mathcal{L}}$  does not agree with  $\mathcal{L}$ , it satisfies the hypotheses of Theorem 3.1 with the same structural constants  $n$ ,  $\lambda$  and  $\Lambda$ . We then apply Theorem 3.1 to the function  $\tilde{u}$  and we plainly obtain our claim for  $u$ .  $\square$

An useful tool in the proof of our main theorem is the following lemma (Lemma 2.2 in [6]). To give here its statement we introduce a further notation. We choose any  $S \in ]0, R[$  and we set

$$K^- = [-S, S]^n \times [-S^3, S^3]^n \times \{ -(\Delta + R^2/2) \}.$$

Moreover, for every  $(v, x, t) \in \mathbb{R}^{2n+1}$  and  $r > 0$  we let

$$K_r^-(v, x, t) = (v, x, t) \circ d_r(K^-).$$

We have that

**Lemma 3.3** *Let  $\gamma : [0, T] \rightarrow \mathbb{R}^{2n+1}$  be an  $\mathcal{L}$ -admissible path and let  $a, b$  be two constants s.t.  $0 \leq a < b \leq T$ . Then there exists a positive constant  $h$ , only depending on  $\mathcal{L}$ , such that*

$$\int_a^b |\omega(\tau)|^2 \delta\tau \leq h \quad \implies \quad \gamma(b) \in K_r^-(\gamma(a)), \quad \text{with } r = \sqrt{\frac{b-a}{(\Delta + 1/2)}}.$$

**Remark 3.4** *Note that  $K_r^-(v, x, t)$  is a compact subset of  $Q_r^-(v, x, t)$  for every  $(v, x, t) \in \mathbb{R}^{2n+1}$  and for any  $r > 0$ . As a consequence of Lemma 3.3,  $K_r^-(\gamma(a))$  is an open neighborhood of  $\gamma(b)$ .*

## 4 Proof of the main results

An useful notion in the proof of our main result is that of HARNACK CHAIN.

**Definition 4.1** *We say that  $\{z_0, \dots, z_k\} \subseteq \Omega$  is a Harnack chain connecting  $z_0$  to  $z_k$  if there exist  $k$  positive constants  $C_1, \dots, C_k$  such that*

$$u(z_j) \leq C_j u(z_{j-1}) \quad j = 1, \dots, k$$

for every non-negative solution  $u$  of  $\mathcal{L}u = f$  in  $\Omega$ .

Our first result of this Section is a local version of Theorem 1.1.

**Proposition 4.2** *For every  $(v, x, t) \in \operatorname{int}(\mathcal{A}_{(v_0, x_0, t_0)})$  there exist an open neighborhood  $U_{(v, x, t)}$  of  $(v, x, t)$  and a positive constant  $C_{(v, x, t)}$  such that*

$$\sup_{U_{(v, x, t)}} u \leq C_{(v, x, t)} \left( u(v_0, x_0, t_0) + \|f\|_{L^\infty(\Omega)} \right),$$

for every non-negative solution to  $\mathcal{L}u = f$ , with  $f \in L^\infty(\Omega)$ .

PROOF. Let  $(v, x, t)$  be any point of  $\text{int}(\mathcal{A}_{(v_0, x_0, t_0)})$ . We plan to prove our claim by constructing a finite Harnack chain connecting  $(v, x, t)$  to  $(v_0, x_0, t_0)$ . Because of the very definition of  $\mathcal{A}_{(v_0, x_0, t_0)}$ , there exists a  $\mathcal{L}$ -admissible curve  $\gamma : [0, T] \rightarrow \Omega$  steering  $(v_0, x_0, t_0)$  to  $(v, x, t)$ . Our Harnack chain will be a finite subset of  $\gamma([0, T])$ .

In order to construct our Harnack chain, we introduce a further notation. Let  $\tilde{Q} := ]-1, 1[^{2n+1}$  and note that it is an open neighborhood of the origin of  $\mathbb{R}^{2n+1}$ . Because of the continuity of the Galilean change of variable “ $\circ$ ” and of the dilation  $(d_r)_{r>0}$ , for every  $(v', x', t') \in \mathbb{R}^{2n+1}$ , the family

$$\left(\tilde{Q}_r(v', x', t')\right)_{r>0}, \quad \tilde{Q}_r(v', x', t') := (v', x', t') \circ d_r \tilde{Q}, \quad (4.1)$$

is a neighborhood basis of the point  $(v', x', t')$ . Then, again because of the continuity of “ $\circ$ ” and  $(d_r)_{r>0}$ , for every  $s \in [0, T]$  there exists a positive  $r$  such that  $\tilde{Q}_r(\gamma(s)) \subseteq \Omega$ . Thus we can define

$$r(s) := \sup \left\{ r > 0 : \tilde{Q}_r(\gamma(s)) \subseteq \Omega \right\}. \quad (4.2)$$

Note that the function (4.2) is continuous, then it is well defined the positive number

$$r_0 := \min_{s \in [0, T]} r(s). \quad (4.3)$$

As  $Q_r(\gamma(s)) \subset \tilde{Q}_r(\gamma(s))$ , we conclude that

$$Q_r(\gamma(s)) \subseteq \Omega \quad \text{for every } s \in [0, T] \quad \text{and } r \in ]0, r_0]. \quad (4.4)$$

On the other hand, we notice that the function

$$I(s) := \int_0^s |\omega(\tau)|^2 dt, \quad (4.5)$$

is (uniformly) continuous in  $[0, T]$ , then there exists a positive  $\delta_0$  such that  $\delta_0 \leq (\Delta + R^2/2)r_0$  and that

$$\int_a^b |\omega(\tau)|^2 dt \leq h \quad \text{for every } a, b \in [0, T], \quad \text{such that } 0 < a - b \leq \delta_0, \quad (4.6)$$

where  $h$  is constant appearing in Lemma 3.3.

We are now ready to construct our Harnack chain. Let  $k$  be the unique positive integer such that  $(k-1)\delta_0 < T$ , and  $k\delta_0 \geq T$ . We define  $\{s_j\}_{j \in \{0, 1, \dots, k\}} \in [0, T]$  as follows:  $s_j = j\delta_0$  for  $j = 0, 1, \dots, k-1$ , and  $s_k = T$ . As noticed before, the equation (4.6) allows us to apply Lemma 3.3. We then obtain

$$\gamma(s_{j+1}) \in Q_{r_0}^-(\gamma(s_j)) \quad j = 0, \dots, k-2, \quad \gamma(s_k) \in Q_{r_1}^-(\gamma(s_{k-1})), \quad (4.7)$$

for some  $r_1 \in ]0, r_0]$ . We next show that  $(\gamma(s_j))_{j=0, 1, \dots, k}$  is a Harnack chain and we conclude the proof. We proceed by induction. For every  $j = 1, \dots, k-2$  we have that  $\gamma(s_{j+1}) \in Q_{r_0}^-(\gamma(s_j))$ . From (4.4) we know that  $Q_{r_0}(\gamma(s_j)) \subseteq \Omega$ , then we apply Theorem 3.1 and we find

$$\begin{aligned}
u(\gamma(s_{j+1})) &\leq \sup_{Q_{r_0}^-(\gamma(s_j))} u \leq M \left( \inf_{Q_{r_0}^+(\gamma(s_j))} u + \|f\|_{L^\infty(Q(\gamma(s_j)))} \right) \\
&\leq M \left( u(\gamma(s_j)) + \|f\|_{L^\infty(\Omega)} \right).
\end{aligned}$$

Here we rely on the fact that  $u$  is a continuous function. As a consequence we obtain

$$\begin{aligned}
u(\gamma(s_{k-1})) &\leq M(u(\gamma(s_{k-2})) + \|f\|_{L^\infty(\Omega)}) \\
&\leq M(M(u(\gamma(s_{k-3})) + \|f\|_{L^\infty(\Omega)}) + \|f\|_{L^\infty(\Omega)}) \\
&\vdots \\
&\leq M^{k-1}u(\gamma(0)) + \|f\|_{L^\infty(\Omega)} \sum_{i=1}^{k-1} M^i.
\end{aligned}$$

We eventually apply Theorem 3.1 to the set  $Q_{r_1}(\gamma(s_{k-1})) \subseteq \Omega$  and we obtain

$$\sup_{U_{(v,x,t)}} u \leq C_{(v,x,t)} \left( u(v_0, x_0, t_0) + \|f\|_{L^\infty(\Omega)} \right),$$

where  $C_{(v,x,t)} = \sum_{i=1}^k M^i$  and  $U_{(v,x,t)} = Q_{r_1}^-(\gamma(s_{k-1}))$ . As we noticed in Remark 3.4,  $Q_{r_1}^-(\gamma(s_{k-1}))$  is an open neighborhood of  $\gamma(T)$ . This concludes the Proof of Proposition 4.2.  $\square$

PROOF OF THEOREM 1.1. Let  $K$  be any compact subset of  $\text{int}(\mathcal{A}_{(v_0, x_0, t_0)})$ . For every  $(v, x, t) \in K$  we consider the open set  $U_{(v,x,t)}$ . Clearly we have

$$K \subseteq \bigcup_{(v,x,t) \in K} U_{(v,x,t)}.$$

Because of its compactness, there exists a finite covering of  $K$

$$K \subseteq \bigcup_{j=1, \dots, m_K} U_{(v_j, x_j, t_j)},$$

and Proposition 4.2 yields we

$$\sup_{U_{(v_j, x_j, t_j)}} u \leq C_{(v_j, x_j, t_j)} \left( u(v_0, x_0, t_0) + \|f\|_{L^\infty(\Omega)} \right) \quad j = 1, \dots, m_K.$$

This concludes the proof of Theorem 1.1, if we choose

$$C_K = \max_{j=1, \dots, m_K} C_{(v_j, x_j, t_j)}.$$

$\square$

PROOF OF THEOREM 1.2. If  $u$  is a non-negative solution to  $\mathcal{L}u = 0$  in  $\Omega$  and  $K$  is a compact subset of  $\mathcal{A}$ , then  $\sup_K u \leq C_K u(v_0, x_0, t_0)$ . If moreover  $u(v_0, x_0, t_0) = 0$ , we have  $u(v, x, t) = 0$  for every  $(v, x, t) \in K$  and, thus,  $u(v, x, t) = 0$  for every  $(v, x, t) \in \mathcal{A}_{(v_0, x_0, t_0)}$ . The conclusion of the proof then follows from the continuity of  $u$ .  $\square$

## References

- [1] B. ALZIARY, J. P. DÉCAMPS, AND P. F. KOEHL, *A P.D.E. approach to Asian options: analytical and numerical evidence*, J. Banking Finance, 21 (1997), pp. 613–640.
- [2] K. AMANO, *Maximum principles for degenerate elliptic-parabolic operators* Indiana Univ. Math. J., 28,4 (1979), pp. 545–557.
- [3] J. BARRAQUAND AND T. PUDET, *Pricing of American path-dependent contingent claims*, Math. Finance, 6 (1996), pp. 17–51.
- [4] E. BARUCCI, S. POLIDORO, AND V. VESPRI, *Some results on partial differential equations and Asian options*, Math. Models Methods Appl. Sci., 11 (2001), pp. 475–497.
- [5] J.-M. BONY, *Principe du maximum, inégalité de Harnack et unicité du problème de Cauchy pour les opérateurs elliptiques dégénérés*, Ann. Inst. Fourier (Grenoble), 19,1 (1969), pp. 277–304.
- [6] U. BOSCAIN AND S. POLIDORO, *Gaussian estimates for hypoelliptic operators via optimal control*, Rend. Lincei Mat. Appl., 18 (2007), pp. 333–342.
- [7] S. CHANDRESEKHAR, *Stochastic problems in physics and astronomy*, Rev. Modern Phys., 15 (1943), pp. 1–89.
- [8] S. CHAPMAN AND T. G. COWLING, *The mathematical theory of nonuniform gases*, Cambridge University Press, Cambridge, third ed., 1990.
- [9] G. CIBELLI, S. POLIDORO, AND F. ROSSI, *Sharp estimates for Geman-Yor Processes and Application to Arithmetic Average Asian Option*, Submitted.
- [10] C. CINTI, K. NYSTRÖM, AND S. POLIDORO, *A note on Harnack inequalities and propagation sets for a class of hypoelliptic operators*, Potential Anal., 33 (2010), pp. 341–354.
- [11] C. CINTI, A. PASCUCCI AND S. POLIDORO, *Pointwise estimates for a class of nonhomogeneous Kolmogorov equations*, Math. Ann., 340 (2008), pp. 237–264.
- [12] C. CINTI AND S. POLIDORO, *Pointwise local estimates and Gaussian upper bounds for a class of uniformly subelliptic ultraparabolic operators*, J. Math. Anal. Appl., 338 (2008), pp. 946–969.
- [13] F. DELARUE AND S. MENOZZI, *Density estimates for a random noise propagating through a chain of differential equations*, J. Funct. Anal., 259 (2010), pp. 1577–1630.
- [14] M. DI FRANCESCO AND A. PASCUCCI, *On a class of degenerate parabolic equations of Kolmogorov type*, AMRX Appl. Math. Res. Express, (2005), pp. 77–116
- [15] M. DI FRANCESCO AND S. POLIDORO, *Schauder estimates, Harnack inequality and Gaussian lower bound for Kolmogorov-type operators in non-divergence form*, Adv. Differential Equations, 11 (2006), pp. 1261–1320.

- [16] J. J. DUDERSTADT AND W. R. MARTIN, *Transport theory*, John Wiley & Sons, New York-Chichester-Brisbane, 1979. A Wiley-Interscience Publication.
- [17] S. D. EIDELMAN, S. D. IVASYSHEN, AND H. P. MALYTSKA, *A modified Levi method: development and application*, Dopov. Nats. Akad. Nauk Ukr. Mat. Prirodozn. Tekh. Nauki, 5 (1998), pp. 14–19.
- [18] G. B. FOLLAND, *Subelliptic estimates and function spaces on nilpotent Lie groups*, Ark. Mat., 13 (1975), pp. 161–207.
- [19] F. GOLSE, C. IMBERT, C. MOUHOT, A. VASSEUR, *Harnack inequality for kinetic Fokker-Planck equations with rough coefficients and application to the Landau equation*, (to appear on Ann. Sc. Norm. Super. Pisa Cl. Sci. (5), DOI Number: 10.2422/2036-2145.201702\_001 preprint, arXiv.org:1607.08068) (2017).
- [20] L. HÖRMANDER, *Hypoelliptic second order differential equations*, Acta Math., 119 (1967), pp. 147–171.
- [21] A. M. IL'IN, *On a class of ultraparabolic equations*, Dokl. Akad. Nauk SSSR, 159 (1964), pp. 1214–1217.
- [22] A. KOGOJ AND S. POLIDORO, *Harnack Inequality for Hypoelliptic Second Order Partial Differential Operators*, Potential Analysis, 45, 3 (2016), pp 545-555.
- [23] A. KOLMOGOROV, *Zufällige Bewegungen. (Zur Theorie der Brownschen Bewegung.)*”, Ann. of Math., II. Ser., 35 (1934), pp. 116–117.
- [24] A. LANCONELLI AND A. PASCUCCI, *Nash estimates and upper bounds for nonhomogeneous Kolmogorov equations*, to appear in Potential Anal. DOI 10.1007/s11118-017-9622-1, (2017).
- [25] A. LANCONELLI, A. PASCUCCI AND S. POLIDORO, *Gaussian lower bounds for non-homogeneous Kolmogorov equations with measurable coefficients*, Preprint arXiv:1704.07307v1 (2017).
- [26] E. LANCONELLI, S. POLIDORO, *On a class of hypoelliptic evolution operators*, Rend. Sem. Mat. Univ. Politec. Torino, 52 (1994), pp. 29–63.
- [27] E. B. LEE, L. MARKUS, *Foundations of optimal control theory*, John Wiley & Sons Inc., New York, (1967), pp. x+576.
- [28] A. LUNARDI, *Schauder estimates for a class of degenerate elliptic and parabolic operators with unbounded coefficients in  $\mathbb{R}^N$* , Ann. Scuola Norm. Sup. Pisa Cl. Sci. (4), 24 (1997), pp. 133–164.
- [29] M. MANFREDINI, *The Dirichlet problem for a class of ultraparabolic equations*, Adv. Differential Equations, 2 (1997), pp. 831–866.
- [30] D. MORBIDELLI, *Spazi frazionari di tipo Sobolev per campi vettoriali e operatori di evoluzione di tipo Kolmogorov-Fokker-Planck*, Tesi di Dottorato di Ricerca, Università di Bologna, (1998).



- [31] J. MOSER, *A Harnack inequality for parabolic differential equations*, Comm. Pure Appl. Math., 17 (1964), pp. 101–134.
- [32] ———, *Correction to: “A Harnack inequality for parabolic differential equations”*, Comm. Pure Appl. Math., 20 (1967), pp. 231–236.
- [33] A. NAGEL, E. M. STEIN, AND S. WAINGER, *Balls and metrics defined by vector fields. I. Basic properties*, Acta Math., 155 (1985), pp. 103–147.
- [34] A. PASCUCCI, *PDE and martingale methods in option pricing*, Springer-Verlag, Milan, 2011.
- [35] A. PASCUCCI AND S. POLIDORO, *On the Harnack inequality for a class of hypoelliptic evolution equations*, Trans. Amer. Math. Soc., (2004), pp. 4383–4394.
- [36] S. POLIDORO, *On a class of ultraparabolic operators of Kolmogorov-Fokker-Planck type*, Matematiche (Catania), 49 (1994), pp. 53–105.
- [37] ———, *A global lower bound for the fundamental solution of Kolmogorov-Fokker-Planck equations*, Arch. Rational Mech. Anal., 137 (1997), pp. 321–340.
- [38] L. P. ROTHSCHILD AND E. M. STEIN, *Hypoelliptic differential operators and nilpotent groups*, Acta Math., 137 (1976), pp. 247–320.
- [39] J. I. SATYRO, *The smoothness of the solutions of certain degenerate second order equations*, Mat. Zametki, 10 (1971), pp. 101–111.
- [40] W. WANG AND L. ZHANG, *The  $C^\alpha$  regularity of weak solutions of a class of non-homogeneous ultraparabolic equations*, Sci. China Ser. A 52 (2009), pp. 1589–1606.
- [41] W. WANG AND L. ZHANG, *The  $C^\alpha$  regularity of weak solutions of ultraparabolic equations*, Discrete Contin. Dyn. Syst., 29 (2011), pp. 1261–1275.
- [42] M. WEBER, *The fundamental solution of a degenerate partial differential equation of parabolic type*, Trans. Amer. Math. Soc., 71 (1951), pp 24–37.