

**OPEN ACCESS**

Full open access to this and thousands of other papers at <http://www.la-press.com>.

## Lipoprotein Glomerulopathy Associated with a Mutation in Apolipoprotein E

Riccardo Magistroni<sup>1</sup>, Marco Bertolotti<sup>2</sup>, Luciana Furci<sup>1</sup>, Rita Adriana Fano<sup>1</sup>, Marco Leonelli<sup>1</sup>, Livia Pisciotta<sup>3</sup>, Elisa Pellegrini<sup>2</sup>, Laura Calabresi<sup>4</sup>, Stefano Bertolini<sup>3</sup> and Sebastiano Calandra<sup>2</sup>

<sup>1</sup>Department of Surgical, Medical, Dental and Morphological Sciences with Transplant Interest, Oncological and Regenerative Medicine, University of Modena and Reggio Emilia. <sup>2</sup>Department of Biomedical, Metabolic and Neural Sciences, University of Modena and Reggio Emilia. <sup>3</sup>Department of Internal Medicine, University of Genova. <sup>4</sup>Department of Pharmacological and Biomolecular Sciences, University of Milano.

Corresponding author email: [riccardo.magistroni@unimore.it](mailto:riccardo.magistroni@unimore.it)

**Abstract:** Lipoprotein glomerulopathy is a pathological condition characterized by lipid accumulation in the glomerular capillaries that has been associated with the presence of rare mutants of apolipoprotein E (ApoE). We describe a 51-year-old Italian patient presenting Type III hyperlipidemia and proteinuria in whom renal biopsy showed capillary ectasia and intraluminal lipid deposits, suggesting the diagnosis of lipoprotein glomerulopathy. The patient, who had elevated plasma ApoE level, was found to be heterozygous for a mutation in ApoE (Arg150Cys), designated apoE<sub>MODENA</sub>. This mutation induces the formation of ApoE dimers that are detectable under non-reducing conditions. Treatment with hypolipidemic drugs did not result in a complete remission of the proteinuria and was accompanied by a slow but progressive worsening of renal function with the persistence of intracapillary lipid thrombi. The introduction of low-density lipoprotein aphaeresis combined with a more aggressive lipid lowering and antihypertensive therapy resulted in the remission of proteinuria and a substantial improvement of renal function. Switching from low-density lipoprotein aphaeresis to plasma filtration did not result in an equivalent control of renal damage. The patient died of intracranial hemorrhage during an acute episode of malignant hypertension.

**Keywords:** lipoprotein glomerulopathy, APOE gene mutation, mixed hyperlipidemia, kidney, glomerular lipid thrombi, proteinuria

*Clinical Medicine Insights: Case Reports* 2013;6 189–196

doi: [10.4137/CCRep.S12209](https://doi.org/10.4137/CCRep.S12209)

This article is available from <http://www.la-press.com>.

© the author(s), publisher and licensee Libertas Academica Ltd.

This is an open access article published under the Creative Commons CC-BY-NC 3.0 license.

## Introduction

Lipoprotein glomerulopathy (LPG) is a pathological condition characterized by lipid accumulation in the glomerular capillaries and was first described by Saito et al in 1989.<sup>1</sup> The histological hallmark of LPG is the presence of laminated thrombi consisting of lipid droplets within the lumina of dilated glomerular capillaries. Electron microscopy revealed that these lipid deposits show a layered texture resembling fingerprints.<sup>2</sup> These thrombi contain B and E apolipoproteins that can be observed immunohistochemically, suggesting the deposition of plasma lipoprotein particles.<sup>3</sup> The plasma lipid profile of LPG patients is characterized by a variable elevation of very low-density lipoprotein and intermediate-density lipoprotein, resembling that reported in Type III hyperlipidemia associated with homozygosity for apolipoprotein E2 isoform and elevation of plasma ApoE.<sup>2</sup> Occasionally, renal lesions have been reported in the classic type III hyperlipidemia, but in these cases the histological features included glomerulosclerosis associated with foam cells accumulation.<sup>3</sup> LPG has been associated with the presence of rare mutants of apolipoprotein E characterized by amino acid substitutions (mostly located in the LDL binding domain) that predispose the deposition of ApoE/ApoB containing lipoprotein within the glomerular capillaries. These ApoE mutations have been reported mostly in Asian populations.<sup>4</sup> Very few Caucasian cases of LPG patients have been reported.<sup>5,6</sup>

In this report, we extend the previous description<sup>7</sup> of a case of LPG by providing additional details

on the follow-up, genetics, and biochemistry of the patient and her family. We describe an Italian patient with LPG with severe hyperlipidemia associated with an ApoE mutation that induces the formation of ApoE dimers.

## Case Report

A female 51-year-old Italian patient was referred to our outpatient clinic in February 2001 for proteinuria and microhaematuria. She reported a family history positive for intestinal neoplasia, diabetes, dyslipidemia and nephropathy. A deceased first grade cousin (subject III 7 in Fig. 1) had been under dialysis treatment of nephropathy of unknown etiology. Since the age of 45, the patient had been treated with inhibitors of platelet aggregation (lysine acetylsalicylate 160 mg/day) for vestibular symptoms. At 47, she started treatment with atorvastatin 10 mg/day for mixed hyperlipidemia (total cholesterol 375 mg/dL, triglycerides 305 mg/dL). At the first visit to our outpatient clinic, she showed normal renal function and normal fasting blood glucose; TAS, rheumatoid factor, C3 and C4 complement fractions, Venereal Disease Research Laboratory (VDRL), serum immunofixation, plasma immunoglobulins were within the normal values. Markers for hepatitis B virus, hepatitis C virus, and human immunodeficiency virus infections were negative. Routine laboratory parameters are reported in Table 1.

At physical examination, no xantelasma, corneal arcus, or peripheral oedemas were present; BMI was 21.6 kg/m<sup>2</sup>. On ultrasound examination, the kidneys showed regular structure and size. The arterial blood

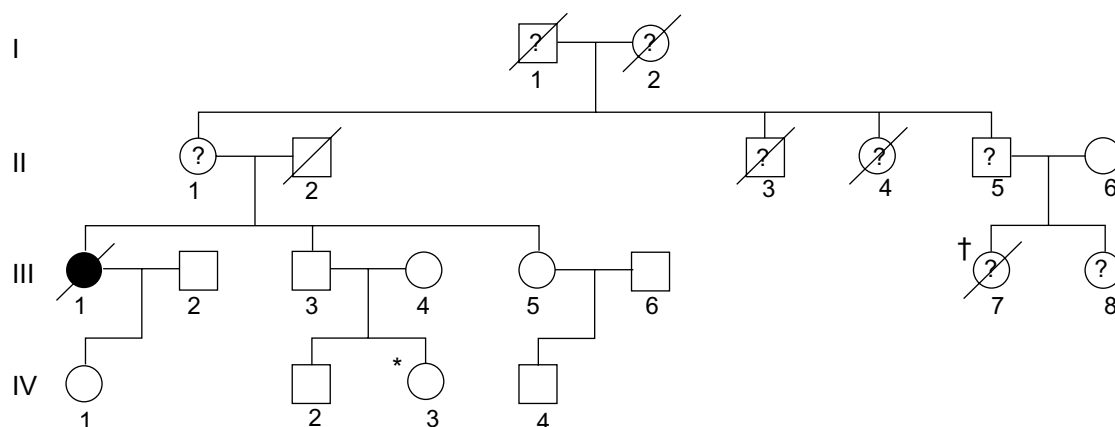

**Figure 1.** Pedigree of the family; the proband described in this case report is indicated by the arrow. A mutation in the ApoE gene was found (ApoE<sub>MODENA</sub>) in this subject. †This subject underwent dialytic treatment; however, clinical, pathological, or molecular data concerning the cause of renal failure are not available; \*this subject developed a nephrotic syndrome; the kidney biopsy showed a minimal change glomerulonephritis, and no endoluminal thrombi were found. This subject was not a carrier of ApoE<sub>MODENA</sub> (see Table 1).

**Table 1.** Annual mean  $\pm$  1 standard deviation for laboratory and clinical data of the patient since presentation (2001) until 2004.

	Normal values	2001	2002	2003	2004
Hemoglobin (g/dL)	12–16	11.9 $\pm$ 0.7	13.2 $\pm$ 0.1	13.3 $\pm$ 0.3	13.7 $\pm$ 0.2
Proteinuria to creatinuria ratio	<0.3	2.86 $\pm$ 1.47	2.41 $\pm$ 0.83	2.75 $\pm$ 0.7	2.3 $\pm$ 0.6
Serum creatinine (mg/dL)	0.6–1.2	0.93 $\pm$ 0.06	1.20 $\pm$ 0.14	1.19 $\pm$ 0.12	1.32 $\pm$ 0.11
GFR according to Cockcroft and Gault (mL/min)	50–90	69.2 $\pm$ 4.5	51.3 $\pm$ 6.0	51.2 $\pm$ 5.1	45.6 $\pm$ 3.8
Total serum protein (g/dL)	6–8	6.05 $\pm$ 0.49	6.40 $\pm$ 0.39	5.90 $\pm$ 0.65	6.10 $\pm$ 0.32
Serum albumin (g/dL)	4.02–4.76	3.14 $\pm$ 0.39	3.85 $\pm$ 0.22	3.44 $\pm$ 0.32	3.72 $\pm$ 0.48
Triglyceride (mg/dL)	<180	342 $\pm$ 190	351 $\pm$ 114	423 $\pm$ 121	231 $\pm$ 99
Cholesterol (mg/dL)	120–200	392 $\pm$ 73	283 $\pm$ 33	340 $\pm$ 15	296 $\pm$ 13
LDL (mg/dL)	<115	270 $\pm$ 48	167 $\pm$ 14	220 $\pm$ 14	180 $\pm$ 27
HDL (mg/dL)	>39	63 $\pm$ 4	59 $\pm$ 1	57 $\pm$ 28	79 $\pm$ 13
Systolic arterial pressure (mmHg)		156 $\pm$ 6	137 $\pm$ 11	162 $\pm$ 10	156 $\pm$ 12
Diastolic arterial pressure (mmHg)		95 $\pm$ 4	92 $\pm$ 3	95 $\pm$ 7	95 $\pm$ 8

pressure was 170/100 mmHg. Hypertension was treated by a combined therapy with ACE-Inhibitor, beta blocker, and calcium blocker (Ramipril 10 mg, Carvedilole 25 mg, and Amlodipine 10 mg/day).

### First biopsy

Renal biopsy showed capillary ectasia accompanied by mesangiolytic. By methenamine silver-Periodic acid-Schiff stain (MPAS) the capillary walls appeared thickened with double contours. Glomerular intraluminal thrombi appeared as weakly periodic acid-Schiff (PAS)-positive deposits or pale blue deposits with Masson-trichrome; the lipid nature of the intraluminal deposits was demonstrated using Black Sudan and oil Red-O staining (Fig. 2 panel A–C;

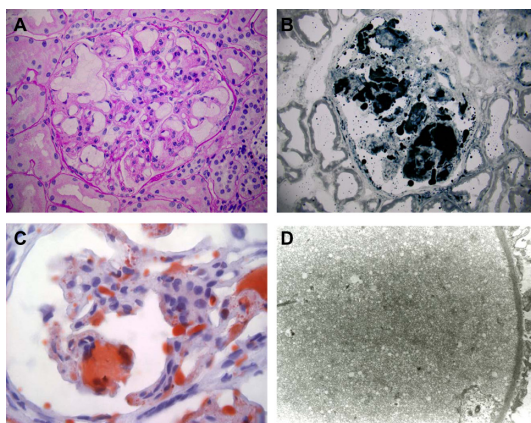

**Figure 2.** (A) capillaries in the glomerulus are distended by lipoprotein thrombi (periodic acid Schiff staining  $\times$ 400); (B) the enlarged capillary lumina contain lipid material stained in black (Sudan Black staining  $\times$ 400); (C) lipid thrombus in a capillary lumen (Red Oil staining  $\times$ 1000); (D) electron micrograph showing finely vacuolated intraluminal electron-dense material ( $\times$ 2500).

Fig. 4—shown in panels A–D). The interstitium was characterized by diffuse fibroedema and tubular atrophy in the areas of fibrosis. Mild infiltration of inflammatory cells was present. The arterioles showed jalin deposits. Immunofluorescence examination showed that some deposits of IgM and C3 were found in the subendothelial space. Ultrastructure analysis confirmed the presence of thrombi in the lumina of the glomerular tufts showing finely vacuolated thrombi (Fig. 2 panel D). These features suggested the diagnosis of LPG. Oil Red O Staining and Black Sudan staining were used for lipid staining on 5- $\mu$ m-thick frozen sections, 10% formalin fixation was applied. Paraffin embedded tissue sections were used for Masson trichrome, periodic acid Schiff, and MPAS staining. The specimen for electron microscopy was fixed with a solution of 4% formalin plus 1% glutaraldehyde in sodium phosphate buffer.

From February 2001 to December 2004, the patient was treated with hypolipemic drugs (atorvastatin 40 mg and omega-3 fatty acids 3000 mg/day) and antihypertensive drugs (carvedilole 25 mg, amlodipine 10 mg, ramipril 10 mg, and irbesartan 300 mg/day). This treatment resulted in a substantial reduction of plasma lipids and arterial blood pressure. Proteinuria to creatinuria ratio was maintained below 3 and renal function improved approaching the lower limits of normal values (Table 1).

### Second biopsy

In early 2005, the patient showed a rapid deterioration of the arterial pressure control, a worsening of

proteinuria and peripheral oedema associated with a deterioration of renal function (Fig. 3). Creatinine was 1.9 mg/dL, albuminemia 2.9 g/dL, and proteinuria 5 g/24 h. Blood pressure was elevated (AP 180/100 mmHg) and difficult to control despite the use of combined therapy with ACE inhibitors, calcium blocker, beta blocker and alpha blocker. The plasma lipid profile was characterized by a further increase in total cholesterol at 445 mg/dL (LDL-C 318 mg/dL, HDL-C 88 mg/dL).

A second renal biopsy confirmed the presence of the lipid thrombi in the capillary lumina (apparently less abundant than in the first biopsy), a significant enlargement and proliferation of the mesangial area, segmental glomerular sclerosis, and expansion of interstitial fibrosis (Fig. 4: panels E–H).

The patient was treated with higher doses of lipid-lowering and antihypertensive drugs, with addition of furosemide and cholestyramine. This treatment was associated with a reduction in arterial blood pressure, proteinuria, and plasma creatinine. However, after

3 months, the levels of proteinuria and creatinine were not normalized. Thus, LDL aphaeresis treatment (heparin mediated extracorporeal low density lipoprotein precipitation, HELP) was started; this treatment regimen has been discussed elsewhere.<sup>7</sup> LDL aphaeresis was performed in three cycles over a period of 30 months (see Fig. 3 and Table 2). This treatment led to an acceptable clinical improvement. Subsequently, as this treatment was not well-tolerated by the patient, so the frequency of LDL aphaeresis sessions was reduced as depicted in Figure 3. However, relapses of proteinuria occurred after the LDL aphaeresis discontinuation. In March 2008, for personal reasons the patient had to be referred to a center where HELP aphaeresis was not available. She was treated by plasma filtration (PF rheofilter, Fresenius AS TEC, Bad Homburg, Germany) until December 2008 (shadowed area in Fig. 3). After this, proteinuria and hypertension worsened, despite medical and aphaeretic treatment. The patient suddenly died of intracranial hemorrhage during an acute episode of malignant hypertension.

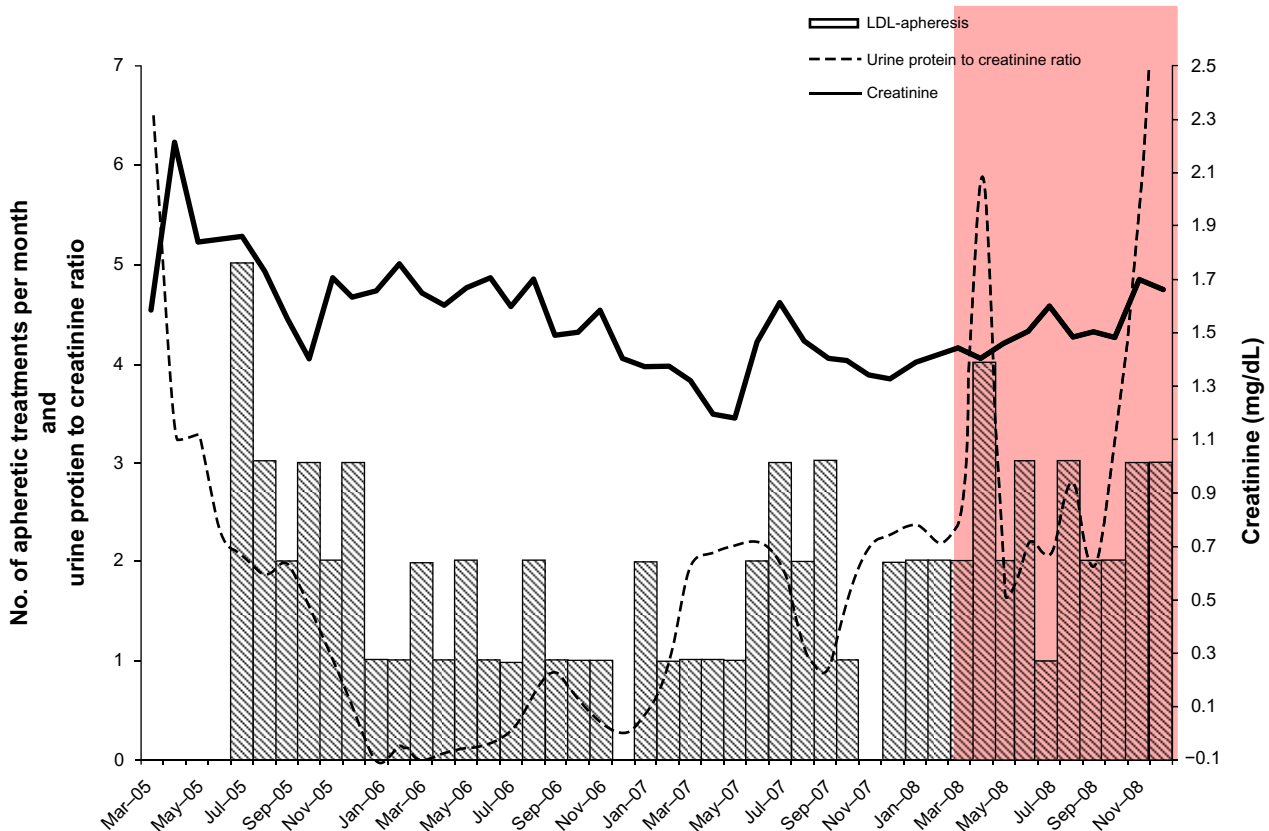

**Figure 3.** The figure shows the frequency of LDL aphaeresis, the creatinine value, and the urine protein to creatinine ratio during treatment. The shadowed region of the panel indicates the period during which the patient switched from HELP aphaeresis to plasma filtration.

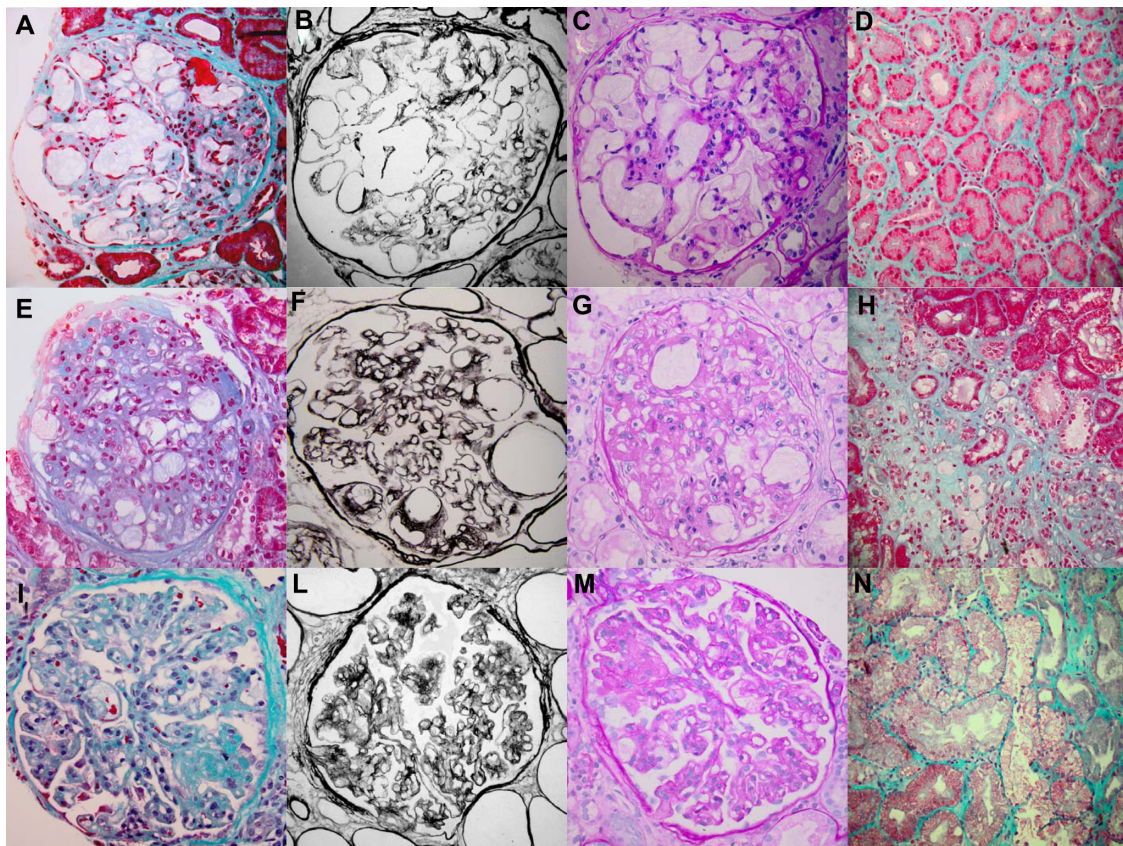

**Figure 4.** Panels **A–D**, were obtained from the first biopsy; panels **E–H** were obtained from the second biopsy; panels **I, L, M** and **N**, were obtained from the post-mortem biopsy. Panels **A, E, I, D, H** and **N**: (Masson's trichrome  $\times 400$ . Panels **B, F** and **L**: MPAS staining,  $\times 400$ . Panels **C, G** and **M** periodic acid Schiff staining  $\times 400$ .

## Post-mortem biopsy

A renal biopsy was performed post-mortem at the time of liver explantation. The evaluation of the specimen showed nearly complete disappearance of glomerular intraluminal deposits as an absence of the typical capillary ectasia. (Fig. 4—available online: panels **I, L, M** and **N**). Tubular atrophy, fibrosis, and inflammatory cells infiltration rate were similar to those observed in the second biopsy.

## DNA sequence analysis

The patient's ApoE genotype was determined by direct sequencing. The sequence of exon 4 showed that the patient was homozygous for  $\epsilon 2$  allele (Cys112 and Cys158 of the mature protein).

In addition, the patient was found to be heterozygous for a mutation in exon 4 of ApoE gene: c.502 C>T (Arg150Cys in the mature protein). This mutation was designated ApoE<sub>MODENA</sub><sup>2</sup> after the city in which the patient was living. This mutation was screened in family members, who gave their consent

for DNA analysis, and in 150 normolipidaemic control subjects. With the exception of the proband (subject III1 in Fig. 1 and Table 3), no carrier of the mutation was found.

## Plasma ApoE level and immunoblot

The plasma ApoE level in the proband was found to be increased (23 mg/dL vs. 3–10 mg/dL in normolipidaemic control subjects). ApoE immunoblot performed in non-reducing conditions showed the presence of a single band (34 kDa) in the control subject and two bands of 34 and ~75 kDa in the proband. Under reducing conditions, only the 34 kDa band was detected in the proband as in the control (Fig. 5).

## Discussion

We described a subject with a long standing dyslipidemia who was referred to nephrologists for the presence of proteinuria and the clinical diagnosis of nephrotic syndrome. The association of proteinuria



**Table 2.** Laboratory and clinical data of the patient before the starting HELP aphaeresis, after 12 months of HELP aphaeresis, and at exitus.

	Normal values	Before HELP aphaeresis	After 12 months of HELP aphaeresis	At exitus
Hemoglobin (g/dL)	12–16	10.2	11.6	9.8
Proteinuria to creatinuria ratio	<0.3	2.1	0.3	10
Serum creatinine (mg/dL)	0.6–1.2	1.86	1.6	1.66
GFR according to Cockcroft and Gault (mL/min)	50–90	31	41	35
Total serum protein (g/dL)	6–8	6.2	6.9	5
Serum albumin (g/dL)	4.02–4.76	3.7	4.1	2.8
Fibrinogen (mg/dL)	200–400	362	362	NA
Triglyceride (mg/dL)	<180	310	149	200
Cholesterol (mg/dL)	120–200	232	171	229
LDL (mg/dL)	<115	137	101	142
HDL (mg/dL)	>39	59	83	74
APOA-I (mg/L)		124	182	NA
Systolic/diastolic (mmHg)		125/75	120/75	200/90
Arterial pressure (mmHg)				

with the presence of lipid deposits in the capillary lumina (so-called lipoprotein thrombi) and a type III hyperlipidemia suggested a diagnosis of LPG.

LPG is characterized by disturbed remnant lipoprotein catabolism, possibly resulting from alterations in ApoE molecule and intravascular glomerular deposition of lipoprotein-containing thrombi. The involvement of ApoE in the pathogenesis of LPG is undeniable, but the mechanisms of its action in this disease remain unknown. A peculiar characteristic of LPG is its strict predilection for the kidney. The increase in the intravascular concentration of lipoproteins carrying conformationally abnormal ApoE molecules during the ultrafiltration of fluid and micromolecules may predispose some individuals to the development of lipoprotein thrombi.<sup>8</sup>

This diagnosis was supported by the finding that the patient was homozygous for the E2 isoform and heterozygous for a mutation in ApoE

(Arg150Cys). She also had elevated plasma level of ApoE. Interestingly, two different mutations of ApoE (both in heterozygous state) affecting the same amino acid residue at position 150 have been reported to be associated with LPG. These mutations include an Arg150Gly substitution (found in a patient homozygous for E2 isoform)<sup>8</sup> and an Arg150Pro substitution (found in a patient homozygous for E3 isoform).<sup>9</sup> Collectively, these three mutations (Arg150Gly, Arg150Pro, and Arg150Cys), which eliminate the arginine residue at position 150, are expected to reduce the affinity of ApoE for the LDL receptor, which is located in the LDL-receptor binding domain.<sup>10</sup> In our patient, this binding defect was expected to be amplified by the homozygosity for the ApoE2 isoform, which is known to have a reduced LDL receptor binding capacity.<sup>10</sup>

Notably, of the 12 mutations of ApoE associated with LPG reported thus far, six are located in the LDL receptor binding domain. This binding defect may

**Table 3.** Genetic and lipidic data of relatives of the proband according to pedigree in Figure 1.

Subject	III.1	III.3	III.5	IV.1	IV.2	IV.3	IV.4
ApoE genotype	ε2ε2	ε2ε3	ε3ε3	ε2ε3	ε2ε3	ε2ε3	ε2ε3
ApoE mutant allele	W/M	W/W	W/W	W/W	W/W	W/W	W/W
Age (years)	51	59	53	29	29	33	15
TC (mg/dL)	331	198	226	158	160	196	139
TG (mg/dL)	227	201	172	72	93	83	54
HDL-C (mg/dL)	60	46	51	68	64	75	62

**Abbreviations:** W, wild-type allele; M, mutant allele (ApoE<sub>MODENA</sub>); TC, Total cholesterol; TG, triglyceride; HDL-C, high-density lipoprotein-cholesterol.

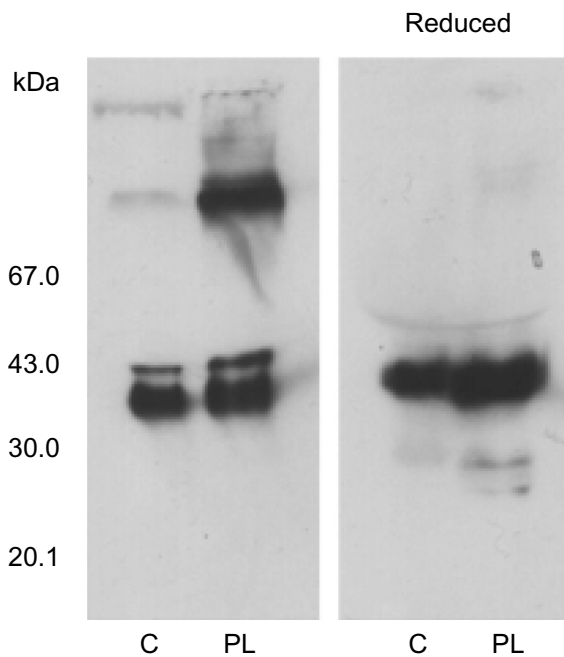

**Figure 5.** Immunoblot of plasma ApoE. Plasma ApoE was separated by SDS-PAGE either in the absence (left panel) or in the presence of  $\beta$ -mercaptoethanol (reducing conditions) (right panel). ApoE was electroblotted onto a nitrocellulose membrane and detected with an anti-human ApoE polyclonal antibody.

**Abbreviations:** C, control subject; PL, LPG patient, heterozygous carrier of ApoE<sub>MODENA</sub>.

be the basis for accumulation of very low-density lipoprotein and intermediate-density lipoprotein in the plasma as the result of a defective LDL-receptor mediated uptake of these lipoproteins by the liver, whereas the type of amino acid change may be responsible for ApoE misfolding and possibly formation of lipoprotein thrombi in the glomerular capillaries. The mutation found in our patient, which introduced a novel cysteine residue, was expected to induce the formation of ApoE dimers due to the formation of novel intermolecular disulphide bridges. This was demonstrated by immunoblotting, which indicated that under reducing conditions, which is similar to the *in vivo* condition, ApoE dimers are formed. These may be homodimers containing two ApoE<sub>MODENA</sub> monomers or heterodimers containing one ApoE<sub>MODENA</sub> and one ApoE2 monomer. These dimers may render ApoE containing lipoproteins more unstable, facilitating their entrapment in the glomerular capillaries.

During the nine years of follow-up, the patient was treated for dyslipidemia, first with lipid-lowering drugs and subsequently with LDL aphaeresis, on the assumption that reduction of plasma lipids could have a beneficial effect on kidney function by reducing lipid

thrombi formation. Treatment with hypolipidemic drugs did not result in remission of the proteinuria and was accompanied by a slow but progressive worsening of renal function with the persistence of intracapillary lipid thrombi, increased interstitial fibrosis, and glomerulosclerosis, as documented by the second biopsy. Only the introduction of LDL aphaeresis and more aggressive lipid-lowering and antihypertensive therapies significantly improved the clinical picture with complete remission of proteinuria and substantial recovery of renal function. Unfortunately, the compliance of the patient to LDL aphaeresis schedule progressively decreased over time, leading to discontinuation of this treatment that was lately replaced by plasma filtration. This discontinuation and change of treatment prevented definite assessment of the long-term impact of HELP aphaeresis on the progression of LPG. Nevertheless, our observations strongly indicate that LDL aphaeresis treatment should be considered in the rare cases of LPG and is in keeping with a previous study where an alternative aphaeretic approach had been adopted. Xin et al<sup>11</sup> reported that protein A immunoabsorption had beneficial effects in a patient with LPG with a disappearance of intraluminal thrombi following treatment, while discontinuation of this treatment was associated with a relapse of proteinuria and deterioration of kidney function.

In conclusion, we described a Caucasian patient with LPG associated with an ApoE mutant (ApoE<sub>MODENA</sub>). Hypolipidemic treatment achieved partial control of the condition that significantly improved only after HELP aphaeresis. However, we are aware that the beneficial effect of HELP aphaeresis on LPG derived from the description of a single case must be substantiated by a prospective clinical trial, requiring a coordinated international effort due to the rarity of LPG.

## Acknowledgements

We thank Doctor Luciana Furci for her contribution in the pathologic evaluation of renal specimens. Furthermore we thank Doctor Juri Piattoni for his clinical contribution to the case description.

## Author Contributions

Made the clinical diagnosis, decided treatment and conducted the follow up: RM, MB, ML, EP. Examined renal biopsies: LF, RF. Conducted the molecular



study: LP, LC. Designed the study and wrote the manuscript: SB, RM, SC. All authors reviewed and approved of the final manuscript.

## Funding

Study was supported by a grant of the Regione Emilia-Romagna (DiALERr project) to SC and a grant of the University of Genova (SB).

## Competing Interests

Author(s) disclose no potential conflicts of interest.

## Disclosures and Ethics

As a requirement of publication the authors have provided signed confirmation of their compliance with ethical and legal obligations including but not limited to compliance with ICMJE authorship and competing interests guidelines, that the article is neither under consideration for publication nor published elsewhere, of their compliance with legal and ethical guidelines concerning human and animal research participants (if applicable), and that permission has been obtained for reproduction of any copyrighted material. This article was subject to blind, independent, expert peer review. The reviewers reported no competing interests.

## References

1. Saito T, Sato H, Kudo K, et al. Lipoprotein glomerulopathy: glomerular lipoprotein thrombi in a patient with hyperlipoproteinemia. *Am J Kidney Dis.* 1989;13(2):148–53.
2. Liberopoulos E, Siamopoulos K, Elisaf M. Apolipoprotein E and renal disease. *Am J Kidney Dis.* 2004;43(2):223–33.
3. Saito T, Ishigaki Y, Oikawa S, Yamamoto TT. Etiological significance of apolipoprotein E mutations in lipoprotein glomerulopathy. *Trend Cardiovasc Med.* 2002;12:67–70.
4. Saito T, Matsunaga A, Oikawa S. Impact of lipoprotein glomerulopathy on the relationship between lipids and renal disease. *Am J Kidney Dis.* 2006;47:199–211.
5. Rovin BH, Roncone D, McKinley A, Nadasdy T, Korbet SM, Schwartz MM. APOE Kyoto mutation in European Americans with lipoprotein glomerulopathy. *N Engl J Med.* 2007;357(24):2522–4.
6. Meyrier A, Dairou F, Callard P, Mougnot B. Lipoprotein glomerulopathy: first case in a white European. *Nephrol Dial Transplant.* 1995;10(4):546–9.
7. Russi G, Furci L, Leonelli M, et al. Lipoprotein glomerulopathy treated with LDL-apheresis (Heparin-induced Extracorporeal Lipoprotein Precipitation system): a case report. *J Med Case Reports.* 2009;3:9311.
8. Tsimihodimos V, Elisaf M. Lipoprotein glomerulopathy. *Curr Opin Lipidol.* 2011;22(4):262–9.
9. Luo B, Huang F, Liu Q, et al. Identification of apolipoprotein E Guangzhou (arginine 150 proline), a new variant associated with lipoprotein glomerulopathy. *Am J Nephrol.* 2008;28(2):347–53.
10. Hatters DM, Peters-Libeau CA, Weisgraber KH. Apolipoprotein E structure: insights into function. *Trends Biochem Sci.* 2006;31:445–54.
11. Xin Z, Zhihong L, Shijun L, et al. Successful treatment of patients with lipoprotein glomerulopathy by protein A immunoabsorption. A pilot study. *Nephrol Dial Transplant.* 2009;24:864–9.