

This is the peer reviewed version of the following article:

Predictive Rolling Bearing Maintenance / Coconcelli, Marco; L., Bassi; D., Borghi; Rubini, Riccardo; Secchi, Cristian. - .

Terms of use:

The terms and conditions for the reuse of this version of the manuscript are specified in the publishing policy. For all terms of use and more information see the publisher's website.

25/04/2024 08:39

(Article begins on next page)



- (51) International Patent Classification:
G01M 13/04 (2006.01)
- (21) International Application Number:
PCT/EP2010/052818
- (22) International Filing Date:
5 March 2010 (05.03.2010)
- (25) Filing Language: English
- (26) Publication Language: English
- (30) Priority Data:
09154474.2 5 March 2009 (05.03.2009) EP
- (71) Applicant (for all designated States except US): **TETRA LAVAL HOLDINGS & FINANCE S.A.** [CH/CH]; Avenue General-Guisan, 70, CH-1009 Pully (CH).
- (72) Inventors; and
- (75) Inventors/Applicants (for US only): **COCCONCELLI, Marco** [IT/IT]; Via Rossena, 3/2, I-42123 Reggio Emilia (IT). **BASSI, Luca** [IT/IT]; Via Nazionale, 134, I-40065 Pianoro (IT). **BORGHI, Davide** [IT/IT]; Via Buoizzi, 339, I-41122 Modena (IT). **RUBINI, Riccardo** [IT/IT]; Via Albini, 32, I-40137 Bologna (IT). **SECCHI, Cristian** [IT/IT]; Via De Amicis, 10/1, I-42020 Quattro Castella (IT).
- (74) Agents: **JORIO, Paolo** et al.; STUDIO TORTA S.r.l., Via Viotti, 9, I-10121 Torino (IT).
- (81) Designated States (unless otherwise indicated, for every kind of national protection available): AE, AG, AL, AM, AO, AT, AU, AZ, BA, BB, BG, BH, BR, BW, BY, BZ, CA, CH, CL, CN, CO, CR, CU, CZ, DE, DK, DM, DO, DZ, EC, EE, EG, ES, FI, GB, GD, GE, GH, GM, GT, HN, HR, HU, ID, IL, IN, IS, JP, KE, KG, KM, KN, KP, KR, KZ, LA, LC, LK, LR, LS, LT, LU, LY, MA, MD, ME, MG, MK, MN, MW, MX, MY, MZ, NA, NG, NI, NO, NZ, OM, PE, PG, PH, PL, PT, RO, RS, RU, SC, SD, SE, SG, SK, SL, SM, ST, SV, SY, TH, TJ, TM, TN, TR, TT, TZ, UA, UG, US, UZ, VC, VN, ZA, ZM, ZW.
- (84) Designated States (unless otherwise indicated, for every kind of regional protection available): ARIPO (BW, GH, GM, KE, LS, MW, MZ, NA, SD, SL, SZ, TZ, UG, ZM, ZW), Eurasian (AM, AZ, BY, KG, KZ, MD, RU, TJ, TM), European (AT, BE, BG, CH, CY, CZ, DE, DK, EE, ES, FI, FR, GB, GR, HR, HU, IE, IS, IT, LT, LU, LV, MC, MK, MT, NL, NO, PL, PT, RO, SE, SI, SK, SM, TR), OAPI (BF, BJ, CF, CG, CI, CM, GA, GN, GQ, GW, ML, MR, NE, SN, TD, TG).
- Published:
— with international search report (Art. 21(3))

(54) Title: PREDICTIVE ROLLING BEARING MAINTENANCE

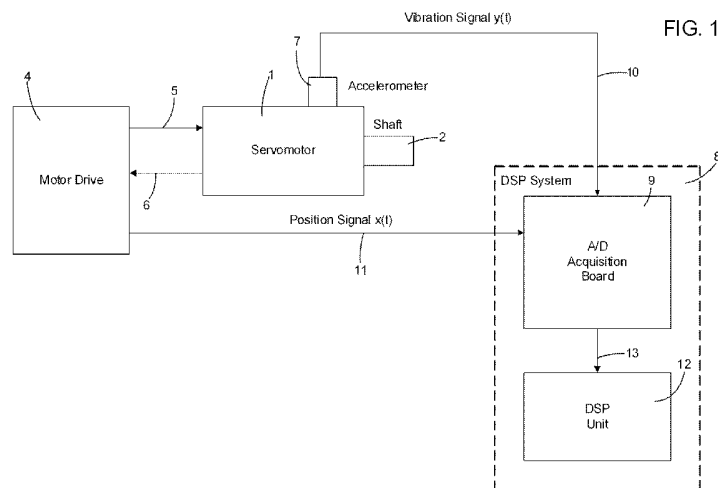

(57) Abstract: A method of predicting a fault in a rolling bearing, the rolling bearing including inner and outer rings and rolling bodies evenly angularly distributed therebetween, the method comprising: processing (in the DSP system 8) a position signal $x(t)$ indicative of a relative angular position of the inner ring with respect to the outer rings, and a vibration signal $y(t)$ (by the accelerometer 7) indicative of speed-related vibrations in the rolling bearing, such that they correspond to either an angular displacement of the rolling bodies equal to an integer number of angular gaps between adjacent rolling bodies or an integer number of complete rotations of the inner ring with respect to the outer ring; space sampling (in the A/D acquisition board 9) the processed vibration signal $y(t)$ based on the processed position signal $x(t)$; and predicting a fault in the rolling bearing based on the space-sampled vibration signal $y(t)$.



PREDICTIVE ROLLING BEARING MAINTENANCE

TECHNICAL FIELD OF THE INVENTION

The present invention relates in general to predictive rolling bearing
5 maintenance, and in particular to maintenance-oriented, condition-based monitoring
of rolling bearings in servomotors operating at an arbitrarily variable low speed and
with (cyclic) motion inversions, such those employed in Filling Machines or
Distribution Equipments of Packaging Lines designed to produce sealed packages
containing a food product.

10

BACKGROUND ART

As is known, on a factory floor of a food packaging plant, several
specifically-aimed processes are generally performed, including incoming food and
packaging material storage, food processing, food packaging, and package
warehousing. With specific reference to pourable food products, food packaging is
15 performed in Packaging Lines, each of which is an assembly of machines and
equipments for the production and handling of packages, and includes a Filling
Machine for the production of sealed packages, followed by one or more defined
configurations of downstream Distribution Equipments such as, accumulators, straw
applicators, film wrappers, and cardboard packers, connected to the Filling Machine
20 via Conveyors, for the handling of the packages.

A typical example of this type of packages is the parallelepiped-shaped
package for liquid or pourable food products known as Tetra Brik Aseptic ®, which
is made by folding and sealing a laminated web of packaging material.

The packaging material has a multilayer sheet structure substantially
25 comprising one or more stiffening and strengthening base layers typically made of a

fibrous material, e.g. paper, or mineral-filled polypropylene material, covered on both sides with a number of heat-seal plastic material layers, e.g. polyethylene film. In the case of aseptic packages for long-storage products, such as UHT milk, the packaging material also comprises a gas- and light-barrier material layer, e.g. aluminium foil or ethyl vinyl alcohol (EVOH) film, which is superimposed on a heat-seal plastic material layer, and is in turn covered with another heat-seal plastic material layer forming the inner face of the package eventually contacting the food product.

Packages of this sort are produced on fully automatic Filling Machines, wherein a continuous vertical tube is formed from the web-fed packaging material; which is sterilized by applying a chemical sterilizing agent such as a hydrogen peroxide solution, which, once sterilization is completed, is removed, e.g. evaporated by heating, from the surfaces of the packaging material; and the sterilized web is maintained in a closed, sterile environment, and is folded and sealed longitudinally to form the vertical tube. The tube is then filled downwards with the sterilized or sterile-processed pourable food product, and is fed along a vertical path to a forming station, where it is gripped along equally spaced cross sections by a jaw system including two or more pairs of jaws, which act cyclically and successively on the tube, and seal the packaging material of tube to form a continuous strip of pillow packs connected to one another by transverse sealing strips. Pillow packs are separated from one another by cutting the relative sealing strips, and are conveyed to a final folding station where they are folded mechanically into the finished, e.g. substantially parallelepiped-shaped, packages.

Alternatively, the packaging material may be cut into blanks, which are formed into packages on forming spindles, and the packages are filled with food product and sealed. One example of this type of package is the so-called "gable-top"

package known as Tetra Rex ®.

In these Packaging Lines, several components are operated by (electric) servomotors, which, although valuable in several respects, are affected by malfunctions, one of the major causes of which is the breakdown of the rolling bearings supporting the shaft of the servomotors due to fatigue or wear. While fatigue can be statistically characterized in a standard way that leads to the so-called *L10 rating* of the bearings, wear is a subtler phenomenon, known in the literature as pitting or brinelling, that creates localized damages, the onset of which may (pseudo)randomly appear during the expected lifetime of the component, followed by a relatively quick degradation phase that leads to the complete breakdown. As a result, periodic replacement of these components is a strategy that may be successful only to prevent fatigue-related failures, whereas it will be almost useless against wear-related failures.

Other kinds of preventive periodic maintenance activities, such as cleaning and lubrication, may be effective in reducing bearing wear, as usually wear is characterized by the contamination of the bearing lubricant which in turn worsens the bearing health. Such contamination may come from the exterior (e.g. the bearing is placed in a hostile environment) but may also be due to internal causes (e.g. due to small flakes of material that the revolving elements lose during operation).

Ultimately, however, the only way to prevent wear-related breakdown is condition-based monitoring of the bearing health status; such maintenance strategy is mainly possible thanks to the fact that once the bearing approaches failure, it becomes noisy and vibrates as a warning sign of the impending breakdown: if this sign is detected timely it gives the operator a time frame that typically ranges from

days to even weeks (depending on the bearing and the application) to plan a maintenance activity and substitute the bearing without impacting production time.

It may be appreciated that vibration analysis is an important part of industrial predictive maintenance programs so that wear and damages in the rolling bearings can be discovered and repaired before the machine breaks down, thus
5 reducing operating and maintenance costs.

Empirical evaluation of the vibration level of a bearing is an error-prone activity that may lead to significantly underestimate or overestimate the remaining lifetime of the component, and also to mistake for a bearing damage a noise that is
10 due to a completely different cause (e.g. a shaft imbalance). For this reason, the scientific community has striven to provide a scientific characterization of bearing faults, and nowadays a rich literature can be found on this topic.

The basic idea is associating each failure mode of a bearing with a characteristic frequency signature, that can be extracted from a vibration signal via
15 an appropriate analysis. In particular, traditional vibration analysis is based on the fact that if there is a localized damage on one of the bearing surfaces, it will cause a series of impacts during bearing rotation; moreover, such impacts are periodic assuming that the servomotor is rotating at constant speed. In fact, a kinematic analysis of the bearing shows that, assuming that no slip is present, the component
20 is quite similar to an epicyclic gear; in other words there is a fixed “transmission ratio” between the servomotor shaft and all the other moving parts of the bearing, and this leads to the fundamental equation of vibration analysis:

$$f_d = k_d f_r \quad (1)$$

25 which shows that f_d , the damage frequency (which is actually the frequency of such

impacts) depends linearly on the rotation frequency f_r by means of a damage coefficient k_d which is none other than the transmission ratio between the servomotor shaft and the moving part on which the damage is located. Such coefficients are well-known in the literature and are given by:

5

$$k_d = \begin{cases} \frac{1}{2} \left(1 - \frac{B_d}{P_d} \cos \theta \right) & = k_g \quad \text{for cage faults} \\ \frac{1}{2} N \left(1 - \frac{B_d}{P_d} \cos \theta \right) & = k_e \quad \text{for outer ring faults} \\ \frac{1}{2} N \left(1 + \frac{B_d}{P_d} \cos \theta \right) & = k_i \quad \text{for inner ring faults} \\ \frac{1}{2} \frac{B_d}{P_d} N \left[1 - \left(\frac{B_d}{P_d} \cos \theta \right)^2 \right] & = k_v \quad \text{for ball faults} \end{cases} \quad (2)$$

where B_d , P_d are ball and pitch diameter, N is the number of revolving elements, θ is an angle that indicates a possible misalignment between inner and outer rings (or rings) as a result of mounting operations (typical values are between 0 and 10 degrees), and wherein the subscript d relates in general to damage frequencies, while subscripts g , e , i and v relate to specific kinds of damage, namely in the inner and outer rings, in the balls evenly angularly spaced apart between the inner and outer rings, and in the cage which retains the balls and which rotates jointly, i.e., at the same speed, with the balls.

The repercussions of this phenomenon on the spectrum of a vibration signal can be easily understood using the basic properties of Fourier transforms: if a single impact is considered, in the time domain this can be represented as a forcing action $d(t)$ of impulsive nature and finite duration T , which tends to an ideal Dirac impulse function $\delta(t)$ as $T \rightarrow 0$; likewise, the spectrum $D(f)$ of said signal will be characterized by a bandwidth that will tend to infinity as $d(t)$ approaches the ideal

20

impulse case (whose Fourier transform is constant over all frequencies).

During the actual component operation the forcing action $u(t)$ will be a periodic repetition at the damage frequency of the original impulse $d(t)$:

$$5 \quad u(t) = \sum_{j=-\infty}^{\infty} d(t - jT_d) \quad (3)$$

By virtue of the properties of the Fourier transform, periodic repetition in time equates to sampling in frequency, which means that the spectrum $U(f)$ of the forcing action that a localized damage applies to the bearing is a discrete spectrum, obtained by sampling the original impulse spectrum $D(f)$:

$$10 \quad U(f) = \sum_{j=-\infty}^{\infty} D(f) \delta(f - jf_d) \quad (4)$$

In practice, this means that the frequency signature of the damage in the vibration signal is a sequence of peaks separated by the characteristic damage frequency of the bearing part damaged.

15 In general, however, the spectrum of a vibration signal acquired on a bearing does not reproduce exactly $U(f)$; it can be rather represented as:

$$Y(f) = G(f)H(f)U(f) + N(f) \quad (5)$$

20 where $G(f)$ is the transfer function of the mechanical assembly, $H(f)$ is the sensor (usually an accelerometer) sensitivity function, and $N(f)$ is any kind of noise superimposed to the fault signal. The spectrum of $Y(f)$ as such may not therefore be the best signal to look at in order to identify a damage signature; the usual procedure to obtain a signal with better signal-to-noise

ratio is called envelope analysis and is based on the following assumptions: there exist a frequency band $[f_1, f_2]$ such that:

- $|G(f)| \gg 1$, that is we are near a mechanical resonance
- $|H(f)| \gg 1$, that is we are in the operational range of the sensor
- 5 • $|N(f)| \ll 1$, which means in practice that we have to look for higher harmonics of the signal $U(f)$.

The latter statement is motivated by the fact that usually mechanical noise is higher at low frequencies. There are some exceptions to this rule, for example noise due to gearing attached to the motor, and in this case it is necessary to resort to
10 more advanced known filtering techniques. If the above hypotheses are satisfied, by band-pass filtering in the frequency band $[f_1, f_2]$ and demodulation of $Y(f)$ it is possible to obtain a signal where some peaks are clearly visible, spaced by f_d .

Summing up, classical vibration analysis is based upon the following hypotheses:

- 15 • there is a localized damage on a bearing;
- the motor the bearing is attached to rotates at a constant speed;
- there is no slip during the relative motion of the bearing elements;
- during the motor operation, the damage causes a series of short-duration impacts, that generate a train of spikes in the frequency spectrum of the vibration
20 signal with a certain periodicity; and
- there is a frequency band where the signal-to-noise ratio is such that the train of impulses is detectable.

If these conditions are not verified, the train of peaks may be smeared so that it is not recognizable anymore, or can be hidden among other kinds of noise.

25 Moreover, the fact that the angle θ in (2) is almost impossible to measure under

practical circumstances adds some difficulties to the task, as each f_d is actually variable in the range of admissible θ 's. Most research in the field has historically been focused to signal processing techniques to obtain better signal-to-noise ratios or to cope with smearing of the peaks due to small fluctuations of velocity or the presence of slip.

Despite the basic assumption of constant rotation speed of the servomotors still holds true for many applications, it proves to be a huge limitation in the field of automatic machines, where usually a number of servomotors are employed as electric cams and operated at a variable speed in order to obtain variable speed profiles of the actuated elements. In particular, as servomotors, usually AC brushless motors, tend to appear more and more often in recent machine designs thanks to their performance being much higher than the mechanical solutions for machine motion in time required to reconfigure the motion profile, in these applications any rolling bearing fault prediction based on frequency signature determined via the above-described classical vibration analysis proves to be unsatisfactory.

In order to extend the above-described classical vibration analysis based on the constant rotation speed assumption to cope with applications in which the rotation speed of the servomotors varies over time, a so-called Order Tracking (OT) vibration analysis has been proposed, which is a frequency analysis that uses multiples, commonly referred to as orders, of the rotation speed, instead of absolute frequencies (Hz) as the frequency base, and is useful for machine condition monitoring because it can easily identify speed-related vibrations such as shaft defects and bearing wear. For a detailed discussion of this technique, reference may be made to R. Potter, *A new order tracking method for rotating machinery*, Sound

and Vibration 24, 1990, 30–34, and K. Fyfe, E. Munck, *Analysis of computed order tracking*, Mechanical System and Signal Processing 11(2), 1997, 187–205.

Order Tracking is based on a constant spatial sampling approach, according to which the vibration signal is sampled at constant angular increments (i.e. uniform $\Delta\theta$), and hence at a frequency proportional to the bearing rotation speed. Traditional order tracking accomplishes this task by using a variable-time data acquisition system, wherein a time-sampling is performed at a frequency which is varied proportionally to the bearing rotation speed. Computed order tracking (COT), instead, accomplishes this task by using a constant-time data acquisition system, wherein the vibration signal is first time-sampled at a constant frequency (i.e. constant-time sampling with uniform Δt), and then the sampled data are digitally spatially re-sampled at constant angular increments (i.e. constant-space sampling with uniform $\Delta\theta$) to provide the desired constant $\Delta\theta$ data. Therefore, Order Tracking maps real time reference t to a modified time reference τ such that the vibration signal is seen as if it were generated piece-wise by a bearing rotating at a constant speed. This mapping results in a modified vibration signal where the frequency signature of a given typology of damage can be found, and in a rolling bearing fault being satisfactorily predicted.

OBJECT AND SUMMARY OF THE INVENTION

The Applicant has experienced that, despite its unquestionable value, Computed Order Tracking is still based on further assumptions about the servomotor operation, such as operation at a high rotation speed (>500 rpm), several shaft revolutions needed for the fault detection, no motion inversions, which prevent its teaching from being satisfactorily applicable to servomotors which operate at arbitrarily variable low rotation speed, are subjected to cyclic motion

inversions, and perform about one shaft revolution per cycle, such as those employed in the food product packaging field to operate the jaw systems.

The objective of present invention is hence to provide a technique which allows the Computed Order Tracking to be applied also to servomotors which operate at arbitrarily variable low rotation speed, are subjected to cyclic motion
5 inversions, and perform about one shaft revolution per cycle, such as those employed in the food product packaging field, to satisfactorily predict servomotor rolling bearing faults, so allowing the current machine maintenance programs to be effectively enhanced.

This objective is achieved by the present invention in that it relates to a
10 method of predicting faults in a rolling bearing, to a digital signal processing system programmed to implement the method, and to a software product designed to implement, when executed, the method, as defined in the appended claims.

BRIEF DESCRIPTION OF THE DRAWINGS

15 For a better understanding of the present invention, preferred embodiments, which are intended purely by way of example and are not to be construed as limiting, will now be described with reference to the attached drawings (all not to scale), wherein:

• Figure 1 shows a general block diagram of a data acquisition system
20 configured to implement a Modified Computed Order Tracking according to the present invention;

• Figure 2 shows a general flowchart of the Modified Computed Order Tracking according to the present invention;

• Figure 3 schematically shows a cross-section of an 8-ball bearing;

25 • Figures 4 and 5 show a “cut & paste” operation according to a first

embodiment of the present invention, to be performed on an acquired position signal $x(t)$ and a filtered vibration signal $y_f(t)$ to test a rolling bearing for a fault in the outer ring;

• Figures 6a and 6b show relative positions of an inner ring and, respectively, of a balls-cage assembly with respect to an outer ring of a rolling bearing plotted versus time;

• Figures 7 and 8 show a “cut & paste” operation according to a first embodiment of the present invention, to be performed on an acquired position signal $x(t)$ and a filtered vibration signal $y_f(t)$ to test a rolling bearing for a fault in the inner ring;

• Figures 9a and 9b show relative positions of an inner ring with respect to an outer ring and, respectively, of a balls-cage assembly with respect to an inner ring of a rolling bearing plotted versus time;

• Figures 10 and 11 show a “cut & paste” operation according to a second embodiment of the present invention, to be performed on an acquired position signal $x(t)$ and a filtered vibration signal $y_f(t)$;

• Figures 12a and 12b show a processed position signal $\hat{x}(t)$ obtained after a “cut & paste” operation and, respectively, a space-sampled position signal $\tilde{x}(t)$ obtained by constant-space sampling a processed position signal $\hat{x}(t)$;

• Figures 13, 14 and 15 show processed space-sampled position and vibration signals obtained by reversing portions of the space-sampled position and vibration signals $\tilde{x}(t)$ and $\tilde{y}(t)$ corresponding to the falling ramps of the space-sampled position signals $\tilde{x}(t)$ shown in Figures 5, 7 and 11, respectively; and

• Figures 16 and 17 show frequency spectra of the reversed vibration signal shown in Figure 13, wherein the damage frequencies relating to an outer ring

fault and an inner ring fault are depicted.

**DETAILED DESCRIPTION OF PREFERRED EMBODIMENTS OF THE
INVENTION**

5 The following description is presented to enable a person skilled in the art to make and use the invention. Various modifications to the embodiments will be readily apparent to those skilled in the art, without departing from the scope of the claimed invention. Thus, the present invention is not intended to be limited to the embodiments shown, but is to be accorded the widest scope consistent with the principles and features disclosed herein and defined in the appended claims.

10 The basic idea underlying the present invention is to appropriately modify the traditional Computed Order Tracking to take into account the specific motion profile, namely cyclic motion inversions and about one shaft revolution per cycle, of the servomotors employed in the food product Packaging Lines, so as to provide what hereinafter will be called Modified Computed Order Tracking (MCOT).

15 Figure 1 shows a general block diagram of a data acquisition system configured to implement the MCOT according to the present invention. In particular, in Figure 1, reference numeral 1 designates a servomotor with a shaft 2 rotatably supported by a rolling bearing 3 (Figure 3) comprising an inner ring 3a, and outer ring 3b, and rolling bodies 3c retained and evenly angularly distributed between the inner
20 and outer rings 3a, 3b by a cage 3d, and whose faults are to be predicted via the MCOT, and which may be operated either cyclically in one and the same direction, namely without any rotation inversion, or to cyclically reverse its rotation direction; reference numeral 4 designates the servomotor drive, which supplies the servomotor 1 with electric power via a power cable 5, receives from the servomotor 1, via a feedback
25 cable 6, a feedback signal generated by a high-resolution encoder (not shown)

associated with the servomotor shaft 2, and outputs a position signal $x(t)$ which is generated based on the feedback signal from the servomotor 1 and is indicative of the angular position of the servomotor shaft 2, and hence of the inner ring 3a with respect to the outer ring 3b of the rolling bearing 3; reference numeral 7 designates an
5 accelerometer, which is associated with the monitored rolling bearing 3 and outputs a vibration signal $y(t)$ which is indicative of the intensity of the vibrations in the rolling bearing 3; and reference numeral 8 designates a digital signal processing system configured to implement the MCOT according to the present invention. In particular, the digital signal processing system 8 includes an A/D acquisition board 9, which
10 receives the vibration signal $y(t)$ from the accelerometer 7 via a connection cable 10 and the position signal $x(t)$ from the servomotor drive 4 via a connection cable 11, and which is configured to simultaneously constant-time sample the position and vibration signals $x(t)$ and $y(t)$, so that at each sampling time t a couple of values $x, y \in \mathfrak{R}^{ns}$ are generated, such that $x = [x(t_1), \dots, x(t_{ns})]$ and $y = [y(t_1), \dots, y(t_{ns})]$ are
15 synchronized with each other; and a digital signal processing (DSP) unit 12, which is connected to the A/D acquisition board 9 via a connection cable 13 to receive the time-sampled position and vibration signals, still designated by $x(t)$ and $y(t)$, and is programmed to process these signals according to the MCOT of the present invention, which will be hereafter described with reference to the general flowchart shown in
20 Figure 2.

As shown in Figure 2, the first step of the MCOT (block 100) is identifying a candidate bearing component to be tested for faults (e.g., inner ring fault, outer ring fault, etc.). In particular, the candidate bearing component to be tested for faults is indicated by an operator via a Graphical User Interface (GUI) implemented
25 by the digital signal processing system 8, and is necessary because testing different

bearing components for faults requires separate executions of the MCOT, as the reader will appreciate afterwards when the third step of the MCOT is described.

The second step of the MCOT (block 200) is identifying a suitable frequency band $[f_1, f_2]$ where the envelope analysis on the time-sampled vibration signal $y(t)$ is performed: this means identifying a resonance frequency in the assembly wherein the servomotor is placed, and it can be done either by simulation or measurement. Such information is application-specific and therefore not likely to change by replacing the servomotor or even by moving to another machine of the same model. Once the suitable frequency band has been identified, the time-sampled position signal $x(t)$ and the time-sampled vibration signal $y(t)$ are acquired over a given acquisition time period, for example of 50 s, and then the time-sampled vibration signal $y(t)$ is band-pass filtered in $[f_1, f_2]$ and demodulated, so obtaining what hereinafter will be referred to as filtered vibration signal $y_f(t)$.

Filtering and demodulation of the time-sampled vibration signal $y(t)$ is carried out because the filtered vibration signal $y_f(t)$ has a bandwidth equal to $f_2 - f_1$, which is generally much lower than the one of the time-sampled vibration signal $y(t)$, and this may improve significantly the readability of the results, especially in highly noisy environments.

The third step of the MCOT (block 300) is processing the time-sampled position signal $x(t)$ and the filtered time-sampled vibration signal $y_f(t)$ according to two different, alternative embodiments of the present invention.

In the first embodiment of the present invention, a particular signal processing is performed which stems from an in-depth analysis of what happens in a faulted bearing during an operating cycle thereof. Let's consider for example a servomotor application wherein the servomotor cyclically reverses its motion every

400°, namely wherein the servomotor has an operating cycle during which the servomotor shaft performs an angular displacement in one direction wider than one complete rotation (a round angle, i.e. 360°), after that it inverts its rotation direction. Let's also consider the case that the rolling bearing is of an 8-ball type shown in Figure 3, wherein each pair of adjacent balls are spaced apart of an angular gap of 45°. In Figure 3, the absolute rotation speeds of the inner and outer rings and of the cage are designate by ω_I , ω_O and ω_C , respectively, and the relative rotation speeds of the inner and outer rings with respect to the intermediate balls-cage assembly, are designate by ω_{I-C} and ω_{O-C} , respectively.

In the servomotor application considered, where the rolling bearing is of an 8-ball type supports the servomotor shaft, and hence the rotation speed of the inner ring is equal to the rotation speed of the servomotor and the outer ring is stationary ($\omega_O=0$), $\omega_{I-C}=\omega_I-\omega_C=\omega_I-J\omega_I=(1-J)\omega_I=0.616\omega_I$, where $J=0.384$ is the transmission ratio between the rotation speeds of the inner ring and the balls-cage assembly in a 8-ball bearing, and $\omega_{O-C}=\omega_C-\omega_O=\omega_C$.

Moreover, the relative angular displacement of the balls-cage assembly with respect to the inner ring is $R_{I-C}=\omega_{I-C}T=(1-J)\omega_I T=0.616\cdot 400^\circ=246.4^\circ$, where T is the time duration of an operating cycle of the servomotor and hence $\omega_I T$ is the angular displacement of the inner ring during the operating cycle of the servomotor, and the relative angular displacement of the balls-cage assembly with respect to the outer ring is $R_{O-C}=\omega_{O-C}T=\omega_C T=J\omega_I T=0.384\cdot 400^\circ=153.6^\circ$.

In view of the foregoing, it may be appreciated that if a fault is present in either the inner or the outer ring, a certain number of impacts will occur between the balls and the faulted ring, and this number clearly depends on where the fault is (inner or outer ring) and on the angular gap between the balls. In particular, if the

fault is in the inner ring, the number of impacts is equal to $\text{int}(R_{I-c}/45) = \text{int}(246.4/45) = \text{int}(5.475) = 5$, while if the fault is in the outer ring, the number of impacts is equal to $\text{int}(R_{O-c}/45) = \text{int}(153.6/45) = \text{int}(3.413) = 3$.

In view of that, it may be appreciated that the fact that in general $R_{I-c}/45$ and $R_{O-c}/45$ are not integers results in the operating cycles of the servomotor generally not ending with an impact, namely in the servomotor performing, after the last impact (third or fifth in the example considered above), an additional angular displacement before reversing the rotation direction.

The Applicant has experienced that this phenomenon adversely affects the acquired vibration signal $y(t)$ to such an extent that the above-described vibration analysis, and in particular the Computed Order Tracking, proves to be unsatisfactory.

Therefore, the signal processing according to the first embodiment of the present invention is aimed at causing the time-sampled position signal $x(t)$ and the filtered vibration signal $y_f(t)$ to look like as if they were generated by an inner ring that continuously rotates in one and the same direction, namely without any inversion of the rotation direction, with respect to the outer ring, and during which the balls-cage assembly performs angular displacements with respect to the inner and outer rings, respectively, each equal to an integer multiple of the angular displacement between two consecutive impacts in the rolling bearing.

This aim is achieved by processing the time-sampled position signal $x(t)$ and the filtered vibration signal $y_f(t)$ such that, in each operating cycle of the servomotor, they correspond to angular displacements of the balls-cage assembly with respect to the inner ring and, respectively, to the outer ring, each of which is equal to a multiple integer of the angular gap between two adjacent rolling elements

of the bearing.

The aforementioned signal processing is accomplished by “cutting & pasting” the time-sampled position signal $x(t)$ and the filtered vibration signal $y_f(t)$ to remove (cut away) those portions thereof which allow the aforementioned result to be achieved.

This operation is shown in Figures 4 to 6, and in Figures 7 to 9, wherein the former three relate to a search for a fault in the outer ring, while the last three relate to a search for a fault in the inner ring. In particular, Figures 4 and 7 show the time-sampled position signals $x(t)$, the filtered vibration signals $y_f(t)$ and those parts thereof, bounded by gray-colored rectangles, to be cut away therefrom, while Figures 5 and 8 show the processed position and vibration signals $\hat{x}(t)$ and $\hat{y}(t)$, which are obtained by pasting one after the other (merging together) the remaining portions of the corresponding time-sampled position signal $x(t)$ and the filtered vibration signal $y_f(t)$.

In particular, Figure 4 relates to a search for a fault in the outer ring, whose relative angular displacement with respect to the balls-cage assembly is 153.6° , during which three impacts between the faults and the balls occur. Therefore, in order for the balls-cage assembly to perform an angular displacement equal to an integer multiple of the angular displacement between two consecutive impacts in the outer ring, such an angular displacement should be $3 \cdot 45^\circ = 135^\circ$ (integer multiple of the angular gap between two adjacent balls of the bearing), which in turn corresponds to an angular displacement of the inner ring of $135^\circ / 0.384 = 351.6^\circ$. Therefore, in order for the time-sampled position signal $x(t)$ to correspond to an angular displacement of the inner ring of 351.6° , portions of the time-sampled position signal $x(t)$ and of the filtered vibration signal $y_f(t)$ corresponding to an

angular displacement of $400^\circ - 351.6^\circ = 48.4^\circ$ of the inner ring are to be cut away.

In order for the retained portions of the time-sampled position signal $x(t)$ and of the filtered vibration signal $y_f(t)$ to be centered in the respective operating cycles of the servomotor, so as to avoid those portions where the servomotor shaft reverses its rotation direction and hence is during a transient rotation state, the portions of the time-sampled position signal $x(t)$ and of the filtered vibration signal $y_f(t)$ that are to be cut away therefrom are those corresponding to both the initial and final portions of the operating cycles of the servomotor, in equal parts, in the example shown in Figure 4 those portions in the ranges 0° to 24.2° and 375.8° to 400° , so retaining those portions in the ranges 24.2° to 375.8° .

The skilled person may appreciate that other portions of the time-sampled position signal $x(t)$ and of the filtered vibration signal $y_f(t)$ than those shown in Figure 4 may be cut away therefrom, which allow the same result to be achieved. For example, there may be cut away those portions of the time-sampled position signal $x(t)$ and of the filtered vibration signal $y_f(t)$ corresponding to either the initial or final portions of the original operating cycles, namely in the ranges 0° to 48.4° or 351.6° to 400° , respectively.

The same computation may be made in the domain of the angular displacement of the balls-cage assembly instead of in the domain of the servomotor shaft. In particular, in order for the time-sampled position signal $x(t)$ to correspond to an angular displacement of the bearing cage of 135° and for the retained portions of the time-sampled position signal $x(t)$ to be centered in the operating cycles, those portions in the ranges 0° to 9.3° and from 144.3° to 153.6° (which, in the domain of the servomotor shaft, correspond to the previously indicated ranges 0° to 24.2° and 375.8° to 400°) are to be cut away, and those portions in the ranges 9.3° to 144.3°

(which, in the domain of the servomotor shaft, correspond to the previously indicated ranges 24.2° to 375.8°) are to be retained.

The aforementioned ranges are depicted in Figures 6a and 6b, where the positions of both the inner ring (Figure 6a) and the balls-cage assembly (Figure 6b) with respect to the outer ring are plotted versus time.

Figure 7 relates instead to a search for a fault in the inner ring, whose relative angular displacement with respect to the balls-cage assembly is 246.4° , and wherein five impacts between the faults and the balls occur. Therefore, in order for the balls-cage assembly to perform an angular displacement equal to an integer multiple of the angular displacement between two consecutive impacts in the inner ring, such an angular displacement should be $5 \cdot 45^\circ = 225^\circ$ (integer multiple of the angular gap between two adjacent balls of the bearing), which in turn corresponds to an angular displacement of the inner ring of $225^\circ / 0.0616 = 365.2^\circ$. Therefore, in order for the time-sampled position signal $x(t)$ to correspond to an angular displacement of the inner ring of 365.2° , portions of the time-sampled position signal $x(t)$ and of the filtered vibration signal $y_f(t)$ corresponding to an angular displacement of $400^\circ - 365.2^\circ = 34.8^\circ$ of the inner ring are to be cut away.

In order for the retained portions of the time-sampled position signal $x(t)$ and of the filtered vibration signal $y_f(t)$ to be centered in the respective operating cycles of the servomotor, so as to avoid those portions where the servomotor shaft reverses its rotation direction and hence is during a transient rotation state, the portions of the time-sampled position signal $x(t)$ and of the filtered vibration signal $y_f(t)$ that are to be cut away therefrom are those corresponding to both the initial and final portions of the operating cycles of the servomotor, in equal parts, in the example shown in Figure 7 those portions in the ranges 0° to 17.4° and 382.6° to 400° , so

retaining those portions in the ranges 17.4° to 382.6° .

The skilled person may appreciate that other portions of the time-sampled position signal $x(t)$ and of the filtered vibration signal $y_f(t)$ than those shown in Figure 7 may be cut away therefrom, which allow the same result to be achieved.

5 For example, there may be cut away those portions of the time-sampled position signal $x(t)$ and of the filtered vibration signal $y_f(t)$ corresponding to either the initial or final portions of the original operating cycles, namely in the ranges 0° to 34.8° or 365.2° to 400° , respectively.

The same computation may be made in the domain of the angular
10 displacement of the balls-cage assembly instead of in the domain of the servomotor shaft. In particular, in order for the time-sampled position signal $x(t)$ to correspond to an angular displacement of the bearing cage of 225° and for the retained portions of the time-sampled position signal $x(t)$ to be centered in the operating cycles, those portions in the ranges 0° to 10.7° and from 235.7° to 246.4° (which, in the domain
15 of the servomotor shaft, correspond to the previously indicated ranges 0° to 17.4° and 382.6° to 400°) are to be cut away, and those portions in the ranges 10.7° to 235.7° (which, in the domain of the servomotor shaft, correspond to the previously indicated ranges 17.4° to 382.6°) are to be retained.

The aforementioned ranges are depicted in Figures 9a and 9b, where the
20 positions of both the inner ring with respect to the outer ring (Figure 9a) and the balls-cage assembly with respect to the inner ring (Figure 9b) are plotted versus time.

In view of the foregoing, it may be appreciated that the angular gap between two adjacent rolling elements of the bearing depends on the type and geometry of
25 the rolling bearing, and hence that the aforementioned signal processing depends, in

addition to which bearing component is to be tested for faults (inner ring or outer ring), also on the geometrical parameters of the bearing.

In a second embodiment of the present invention, the time-sampled position signal $x(t)$ and the filtered vibration signal $y_f(t)$ are processed such that they correspond to an integer number of complete rotations (360°) of the inner ring with respect to the outer ring, namely such that they look like as if they were generated by an inner ring that continuously rotates in the same direction, namely without any inversion of the rotation direction, with respect to the outer ring, and during which it performs an integer number of complete rotations with respect to the outer ring. Clearly, the higher the number of complete rotations, the richer the information based on which the vibration analysis will be performed.

Also in this second embodiment, this task is accomplished by carrying out a “cut & paste” operation on the time-sampled position signal $x(t)$ and the filtered vibration signal $y_f(t)$ similar to that previously described with reference to the first embodiment of the present invention.

This operation is shown in Figures 10 and 11, which are similar to Figures 4 and 5, and wherein the portions of the time-sampled position signal $x(t)$ and of the filtered vibration signal $y_f(t)$ that are to be cut away therefrom are those corresponding to the final portions of the original operating cycle, namely the portion exceeding 360° , i.e., in the ranges 360° to 400° .

The skilled person may appreciate that other portions of the time-sampled position signal $x(t)$ and of the filtered vibration signal $y_f(t)$ than those shown in Figure 10 may be cut away therefrom, which allow the same result to be achieved.

For example, there may be cut away those portions of the time-sampled position signal $x(t)$ and of the filtered vibration signal $y_f(t)$ corresponding to the

initial portions of the original operating cycles, namely the portions in the ranges 0° to 40° , or those portions of the time-sampled position signal $x(t)$ and of the filtered vibration signal $y_f(t)$ corresponding to both the initial and final portions of the original operating cycles, conveniently in equal parts, for example those portions in
5 the ranges 0° to 20° and 380° to 400° , so resulting in the retained portions of the time-sampled position signal $x(t)$ and of the filtered vibration signal $y_f(t)$ being centered in the respective operating cycles.

It is worth noting that the “cut & paste” operation may be superfluous if the rotation of the bearing under test is monotonic and ramp-like, as long as there is a
10 certain number of complete rotations in the time-sampled position signal $x(t)$ and the filtered vibration signal $y_f(t)$, but becomes crucial in case of a cyclic motion. This operation is done with the help of the transmission coefficients in (2) and in practice outputs, as result, two vectors $\hat{y}, \hat{x} \in \mathfrak{R}^n$.

In view of the foregoing, it may be appreciated that in order for the time-
15 sampled position signal $x(t)$ and the filtered time-sampled vibration signal $y_f(t)$ to be processed as described above, it is not necessary any more to know in advance which is the candidate bearing component to be tested for faults, and hence in this second embodiment this step may be omitted.

It is also worth noting that the two embodiments of the present invention
20 have been described with reference to a servomotor application wherein the rolling bearing supports the servomotor shaft and hence the outer ring is fixed to a stationary part of the servomotor, while the inner ring is rotatably coupled to the servomotor shaft and hence rotates with respect to the outer ring at the same speed of the servomotor. Therefore, in the application considered the relative rotation of
25 the inner ring with respect to the outer ring corresponds to the rotation of the

servomotor shaft. However, it may be appreciated that what has been previously described with respect to the application considered may be applied generally to any other application wherein the inner and outer rings relatively rotates one with respect to the other, namely wherein the inner ring is fixed to a stationary member and the outer ring is rotatably coupled with a rotating member, and wherein both the inner and the outer rings are rotatably coupled to rotating members which rotate in the same or different directions.

The skilled person will also appreciate that the teaching of the present invention also apply to rolling bearings that are structurally different from, but operatively equivalent to the one previously described, in particular to rolling bearings wherein the rolling bodies are retained and evenly angularly spaced apart by retaining means other than the cage described above, or rolling bearings without either an inner or an outer ring, namely wherein the rolling bodies directly rest on, and are radially retained by either an inner or, respectively, an outer rotating member, which, hence, plays the role of the corresponding missing ring.

With reference again to the flowchart shown in Figure 2, the fourth step of the MCOT (block 400) is space sampling, in particular constant-space sampling, the processed position and vibration signals $\hat{x}(t)$ and $\hat{y}(t)$, such that they are respectively transformed to space-sampled position and vibration signals $\tilde{x}(t)$ and $\tilde{y}(t)$ under a non-linear re-sampling law, defined as a mapping $F: \mathfrak{R}^n \times \mathfrak{R}^n \times \mathfrak{R} \rightarrow \mathfrak{R}^m$, whose arguments are:

$$[\tilde{y}(\tau_1), \dots, \tilde{y}(\tau_m)] = F[\hat{y}(t_1), \dots, \hat{y}(t_n), \hat{x}(t_1), \dots, \hat{x}(t_n), \Delta x] \quad (6)$$

where Δx represents the spatial sampling period, which is related to the minimum physical size of the fault that can be detected by the algorithm, and is in the order of

magnitude of tenths or hundredths of degrees.

Expressed in pseudo-code, mapping F is:

```

 $\tilde{y}(\tau_1) := \hat{y}(t_1);$ 
 $\tau_1 := 0;$ 
 $i := 2;$ 
 $j := 2;$ 
 $x_{last} := x(t_1);$ 
while  $i \leq n$ 
  while  $|\hat{x}(t_i) - x_{last}| < \Delta x$ 
     $i := i + 1;$ 
  end
   $x_{curr} := x_{last} + \text{sgn}(\hat{x}(t_i) - x_{last})\Delta x;$ 
   $\tau_j := \tau_{j-1} + \Delta x;$ 
   $\tilde{y}(\tau_j) := (\hat{y}(t_i) - \hat{y}(t_{i-1})) \left[ \frac{x_{curr} - \hat{x}(t_i)}{\hat{x}(t_i) - \hat{x}(t_{i-1})} + 1 \right] + \hat{y}(t_{i-1});$ 
   $j := j + 1;$ 
   $x_{last} := x_{curr};$ 
end

```

which means, in simple terms, that the points in \tilde{y} are separated by a variable time span, but a fixed rotation. If it is not possible to find a point in \tilde{y} which corresponds to the desired rotation space, the algorithm interpolates linearly between the two closest values.

It is worth noting that, as shown in Figures 12a and 12b, as the processed position signal $\hat{x}(t)$ increases monotonically with time t (Figure 12a), then the space-sampled position signal $\tilde{x}(t)$, when plotted vs. the modified time τ , is a sloped straight line that, when the motion is cyclically reversed, becomes a triangular wave with rising and falling ramps, whose slope is constant in modulus but different in sign (Figure 12b).

Thanks to the mapping F , it is thus possible to generate a space-sampled

vibration signal $\tilde{y}(t)$ where the frequency signature of a given typology of fault can be found (provided that the other previously mentioned assumptions hold). In particular, in order to identify the frequency signature in the space-sampled vibration signal $\tilde{y}(t)$, it is necessary to compute the damage frequency f_d based on (1), which computation requires the preliminary computation of the rotation frequency f_r of the servomotor shaft (or, alternatively, of the inner ring with respect to the outer ring). As the space-sampled position signal $\tilde{x}(t)$ is indicative of the shaft position “as seen” by the constant space sampling, the absolute value of the (constant) slope of the space-sampled position signal $\tilde{x}(t)$ is the rotation frequency f_r sought, which also corresponds to the mean of the absolute value of the rotation speed in the acquisition period. However, as said before with reference to Figure 12, when the rotation of the servomotor shaft, namely the rotation of the inner ring with respect to the outer ring, is cyclically reversed, the space-sampled position signal $\tilde{x}(t)$ has a triangular time development whose slope is constant in modulus but different in sign. Therefore, in order for the rotation frequency f_r to be computed, it is necessary to cause the space-sampled position signal $\tilde{x}(t)$, and the space-sampled vibration signal $\tilde{y}(t)$ accordingly, to look like as if they were produced by a continuous rotation of the inner ring with respect to the outer ring in one and the same direction, i.e., without any inversion of the rotation direction, and at a constant speed throughout the acquisition period, so ensuring a constant sign of the rotation frequency f_r over the entire acquisition period.

Therefore, the fifth step of the MCOT (block 500) is reversing, i.e., overturning (turning upside down), those portions of the space-sampled position and vibration signals $\tilde{x}(t)$ and $\tilde{y}(t)$ corresponding to either of the two groups of rising and falling ramps in the space-sampled position signal $\tilde{x}(t)$. In this way, the

profile of the space-sampled position signal $\tilde{x}(t)$ changes from a triangular one to a saw-toothed one, whose slope is constant both in modulus and in sign over the entire acquisition period, so ensuring a rotation frequency f_r with a constant sign over the entire acquisition period. This reversal (“flipping over”) operation results

5 in the reversed position and vibration signals shown in Figures 13 and 14, wherein the former relates to the first embodiment of the present invention and hence depicts the space-sampled position and vibration signals $\tilde{x}(t)$ and $\tilde{y}(t)$ obtained by space-sampling the processed position and vibration signals $\hat{x}(t)$ and $\hat{y}(t)$ shown in Figure 5, while the latter relates to the second embodiment of the present invention

10 and hence depicts the space-sampled position and vibration signals $\tilde{x}(t)$ and $\tilde{y}(t)$ obtained by space-sampling the processed position and vibration signals $\hat{x}(t)$ and $\hat{y}(t)$ shown in Figure 8, and wherein the portions of the space-sampled position and vibration signals $\tilde{x}(t)$ and $\tilde{y}(t)$ that have been flipped over are those corresponding to the falling ramps of the space-sampled position signal $\tilde{x}(t)$.

15 It is worth stressing that the “flipping over” operation is necessary only when the servomotor shaft, and hence the associated rolling bearing, is operated so as to cyclically reverse its rotation direction, while it is not necessary at all when the servomotor shaft, and hence the associated rolling bearing, is operated cyclically without reversing its rotation direction.

20 It is also worth noting that for cyclic motions the fact that (1) holds also depends on the cutting operation before re-sampling, as this guarantees that for each cycle an integer number of impacts on the potentially damaged component are present.

25 In the end, the sixth and last step of the MCOT (block 600) is computing the rotation frequency f_r and then the damage frequency f_d based on the reversed

position signal, computing the frequency spectrum of the reversed vibration signal by Fast Fourier Transforming the latter, and then by searching for peaks in the frequency spectrum of the reversed vibration signal that are separated in frequency by an amount equal to the damage frequency f_d , as in the classical vibration analysis.

5
10
15

Figures 15 and 16 show two frequency spectra of a reversed vibration signal obtained by implementing twice the MCOT according to the first embodiment of the present invention to test a rolling bearing for a fault in the inner ring and, respectively, in the outer ring. In particular, the frequency signature (damage frequency f_d and the corresponding first higher harmonic thereof) relating to an inner ring fault is depicted by squares in Figure 15, while the frequency signature relating to an outer ring fault is depicted by circles in Figure 16. As may be appreciated, in Figure 15 the damage frequency relating to an inner ring fault is at a value where the envelope of the frequency spectrum has a relative maximum, so being indicative of a fault in the inner ring, while in Figure 16 the damage frequency relating to an outer ring fault is present at a value where the envelope of the frequency spectrum has a relative minimum, so being indicative of no fault in the outer ring.

CLAIMS

1. A method of predicting a fault in a rolling bearing (3), the rolling bearing (3) including inner and outer rings (3a, 3b) and rolling bodies (3c) evenly angularly distributed therebetween, the method comprising:

- 5
- processing a position signal ($x(t)$) indicative of a relative angular position of the inner ring (3a) with respect to the outer ring (3b), and a vibration signal ($y(t)$) indicative of speed-related vibrations in the rolling bearing (3), such that they correspond to either an angular displacement of the rolling bodies (3c) equal to an integer number of angular gaps between adjacent rolling bodies (3c) or an integer
- 10
- number of complete rotations of the inner ring (3a) with respect to the outer ring (3b);
- space sampling the processed vibration signal ($\hat{y}(t)$) based on the processed position signal ($\hat{x}(t)$); and
- predicting a fault in the rolling bearing (3) based on the space-sampled
- 15
- vibration signal ($\tilde{y}(t)$).

2. The method of claim 1, wherein processing the position and vibration signals ($x(t), y(t)$) includes:

- removing from the position and vibration signals ($x(t), y(t)$) those portions thereof that cause the same not to correspond to either an angular
- 20
- displacement of the rolling bodies (3c) equal to an integer number of angular gaps between adjacent rolling bodies (3c) of the rolling bearing (3) or an integer number of complete rotations of the inner ring (3a) with respect to the outer ring (3b); and
- merging the remaining portions of the position and vibration signals ($x(t), y(t)$) one after the other.

25

3. The method of claim 1 or 2, wherein, when the rolling bearing (3) is

operated cyclically without reversing the relative rotation direction of the inner ring (3a) with respect to the outer ring (3b), processing the position and vibration signals $(x(t), y(t))$ includes:

- processing the position and vibration signals $(x(t), y(t))$ such that they correspond, in each operating cycle, to either an angular displacement of the rolling bodies (3c) equal to an integer number of angular gaps between adjacent rolling bodies (3c) or an integer number of complete rotations of the inner ring (3a) with respect to the outer ring (3b).

4. The method of claim 1 or 2, wherein, when the rolling bearing (3) is operated to cyclically reverse the relative rotation direction of the inner ring (3a) with respect to the outer ring (3b), processing the position and vibration signals $(x(t), y(t))$ includes:

- processing the position and vibration signals $(x(t), y(t))$ such that they correspond, in each operating cycle, to either an angular displacement of the rolling bodies (3c) equal to an integer number of angular gaps between adjacent rolling bodies (3c) or an integer number of complete rotations of the inner ring (3a) with respect to the outer ring (3b); and

- processing the space-sampled vibration signal $(\tilde{y}(t))$ such that it corresponds to a continuous rotation of the inner ring (3a) with respect to the outer ring (3b) in one and the same direction and at a constant speed.

5. The method of claim 4, wherein processing the space-sampled vibration signal $(\tilde{y}(t))$ includes:

- space sampling the processed position signal $(\hat{x}(t))$, whereby generating a space-sampled position signal $(\tilde{x}(t))$ having a substantially triangular time development with rising and falling ramps; and

- reversing those portions of the space-sampled vibration signal ($\tilde{y}(t)$) that correspond to either the rising or the falling ramps in the space-sampled position signal ($\tilde{x}(t)$).

5 6. The method of any one of the preceding claims, wherein processing the position and vibration signals ($x(t)$, $y(t)$) further includes:

- computing a relative angular displacement of the rolling bodies (3c) with respect to a selected one of the inner and outer rings (3a, 3b), such that it is equal to an integer number of angular gaps between adjacent rolling bodies (3c), based on the position signal ($x(t)$); and

10 • processing the vibration signals ($x(t)$, $y_f(t)$) based on the computed relative angular displacement of the rolling bodies (3c).

7. The method of any one of the preceding claims, wherein space sampling includes:

- constant-space sampling.

15 8. The method of any one of the preceding claims, wherein predicting a fault in the rolling bearing (3) includes:

- Fast Fourier Transforming the space-sampled vibration signal ($\tilde{y}(t)$), whereby generating a frequency spectrum of the space-sampled vibration signal ($\tilde{y}(t)$); and

20 • searching for a frequency signature characteristic of the fault.

9. The method of any one of the preceding claims, further including:

- selecting one of the inner and outer rings (3a, 3b); and

- carrying out the method of any one of the preceding claims to test the rolling bearing (3) for a fault in the selected ring (3a, 3b).

25 10. The method of any one of the preceding claims, wherein processing the

position and vibration signals $(x(t), y(t))$ includes:

- time sampling the position and vibration signals $(x(t), y(t))$.

11. The method of any one of the preceding claims, wherein processing the position and vibration signals $(x(t), y(t))$ includes:

- 5
- band-pass filtering and carry out an envelope analysis on the vibration signal $(y(t))$.

12. A digital signal processing system (8) programmed to implement the method according to any one of the preceding claims.

13. A software program loadable into a digital signal processing system (8),
10 and designed to implement, when executed, the method according to any one of the preceding claims 1 to 12.

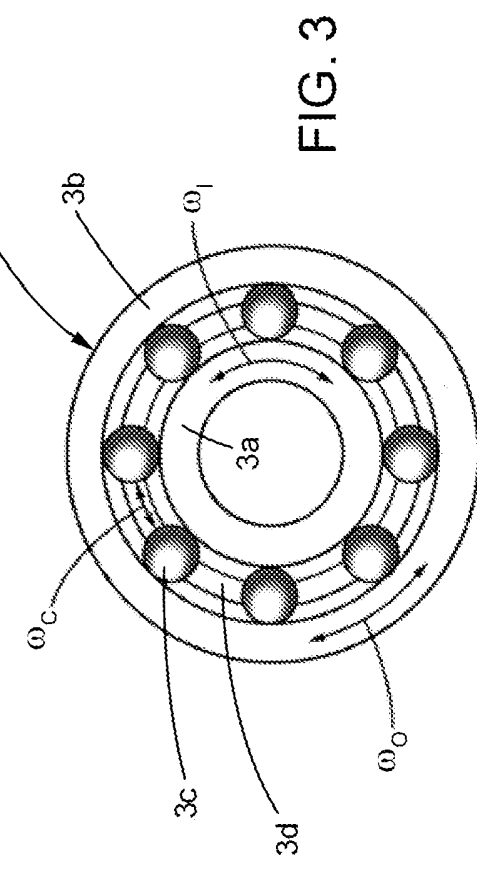
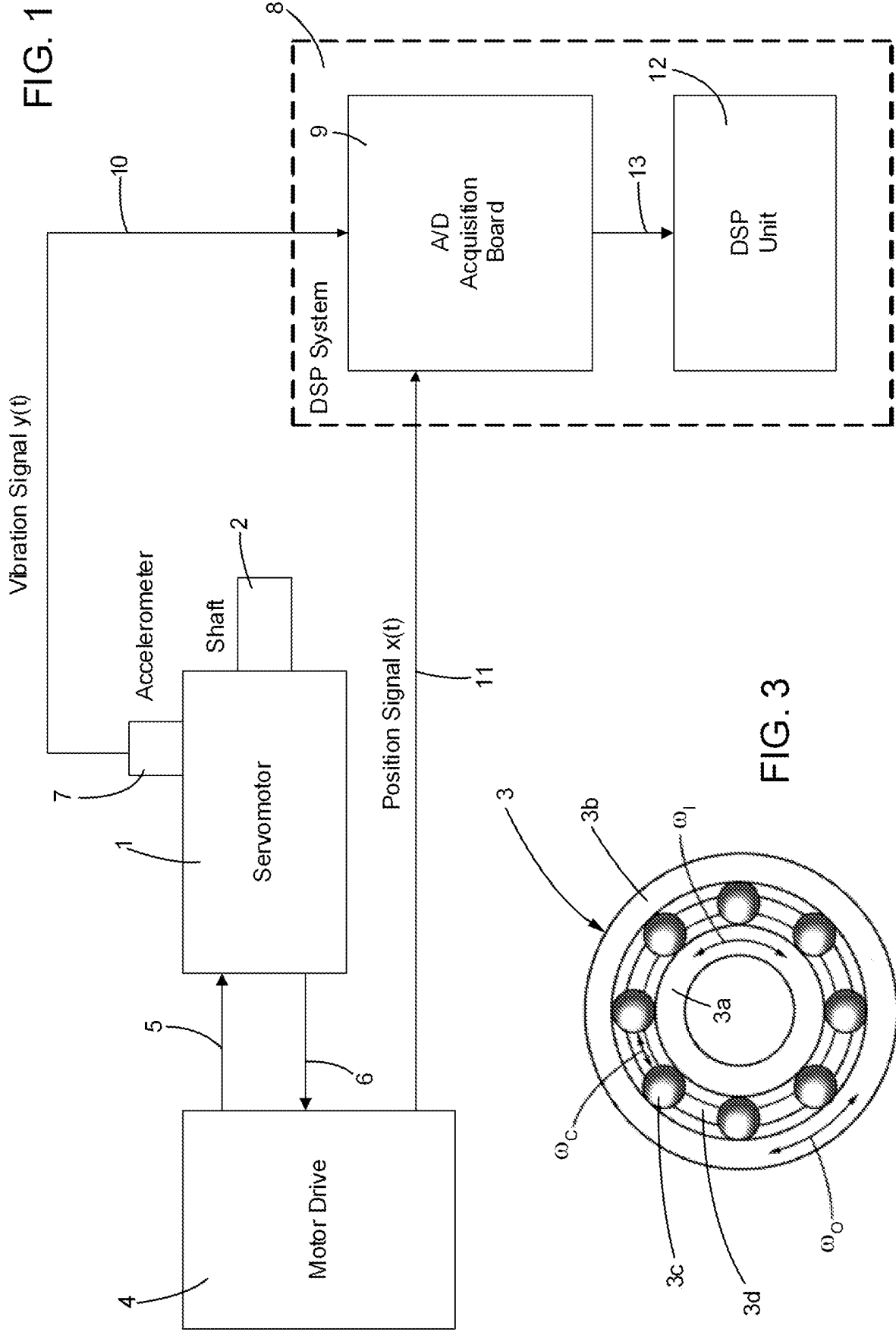

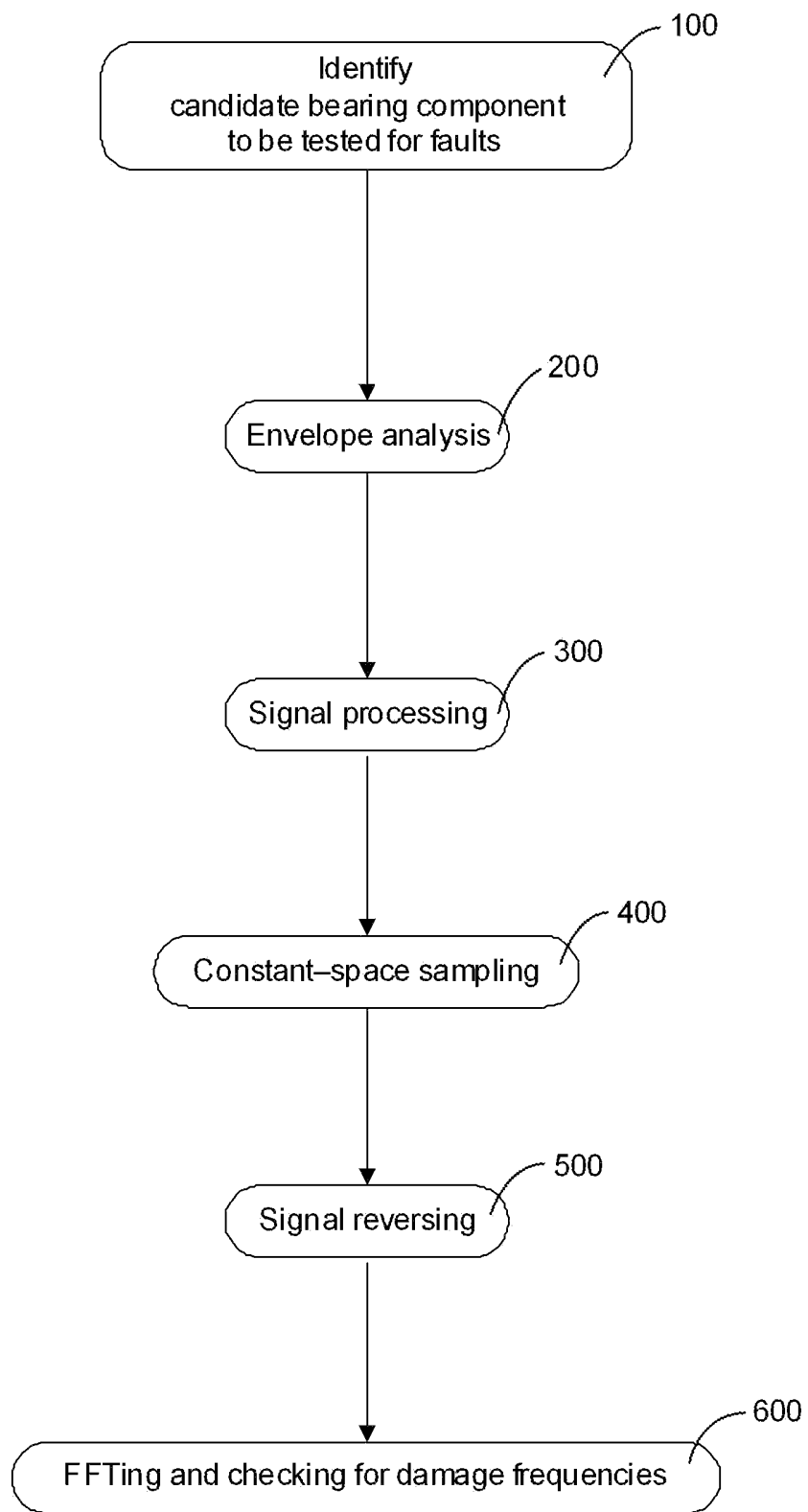

FIG. 2

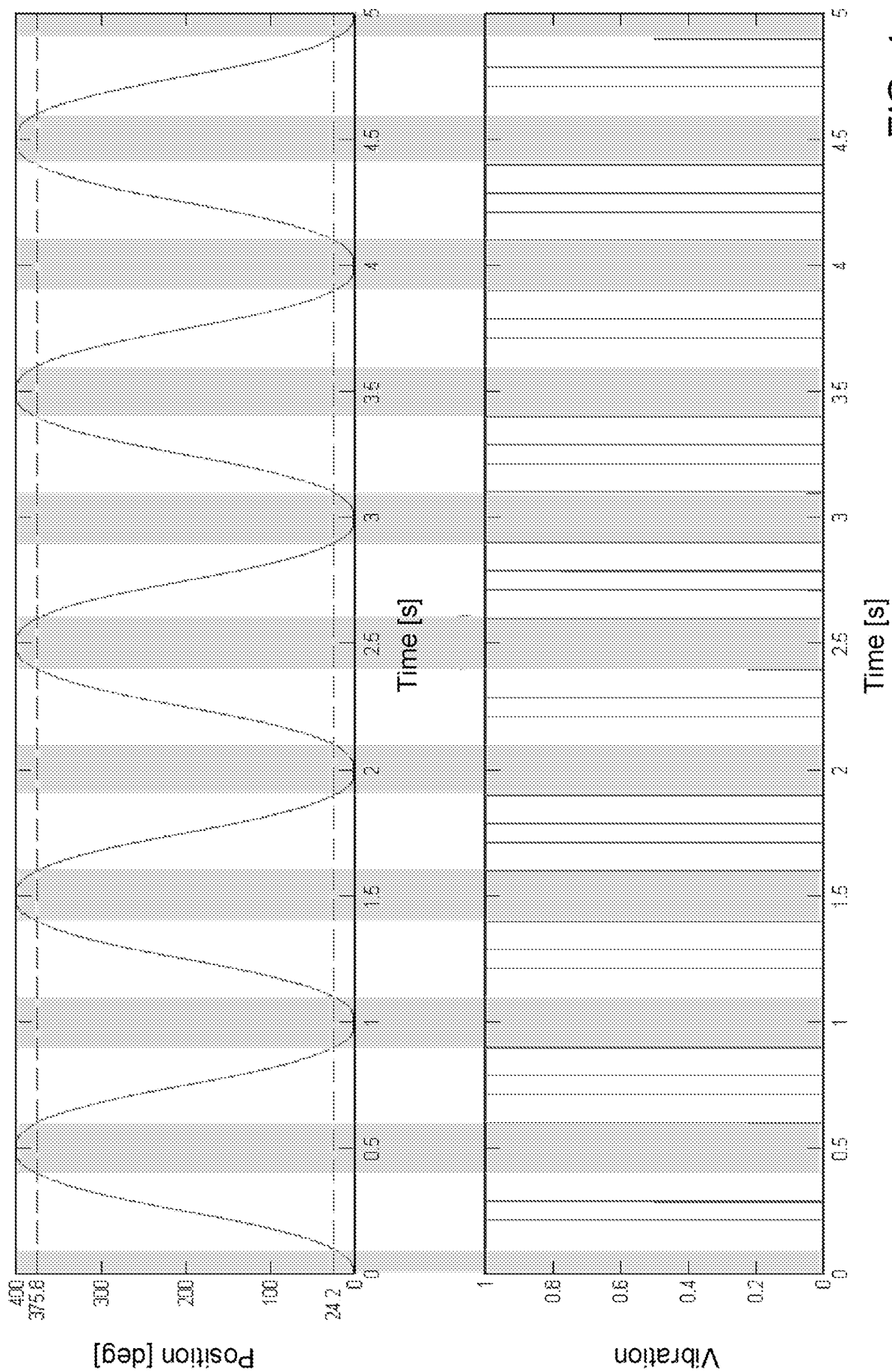

FIG. 4

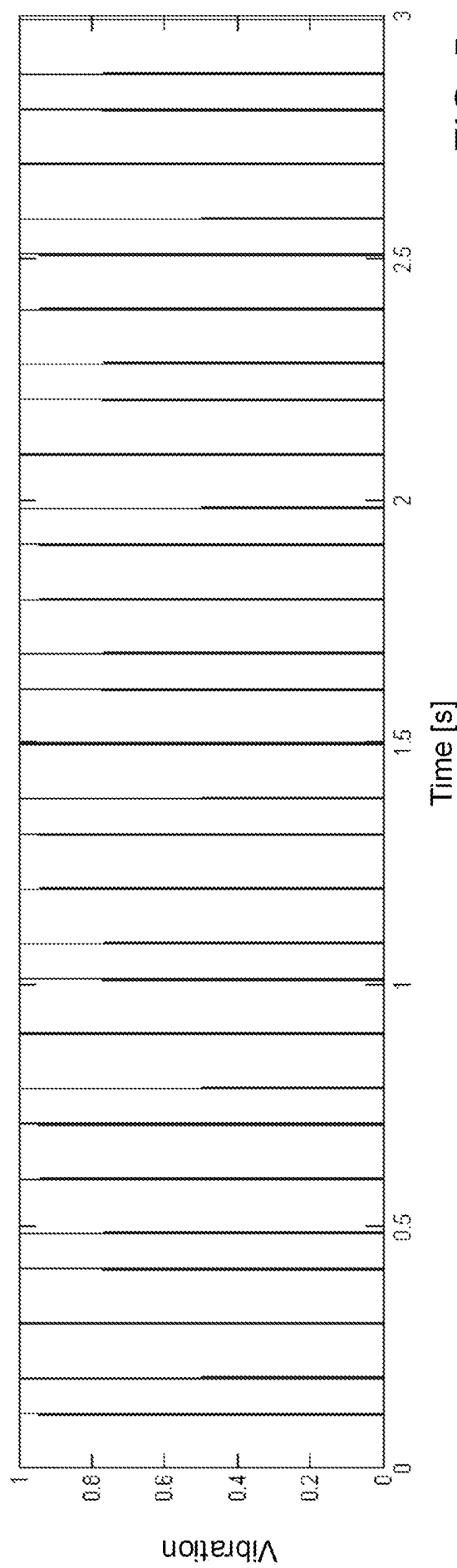
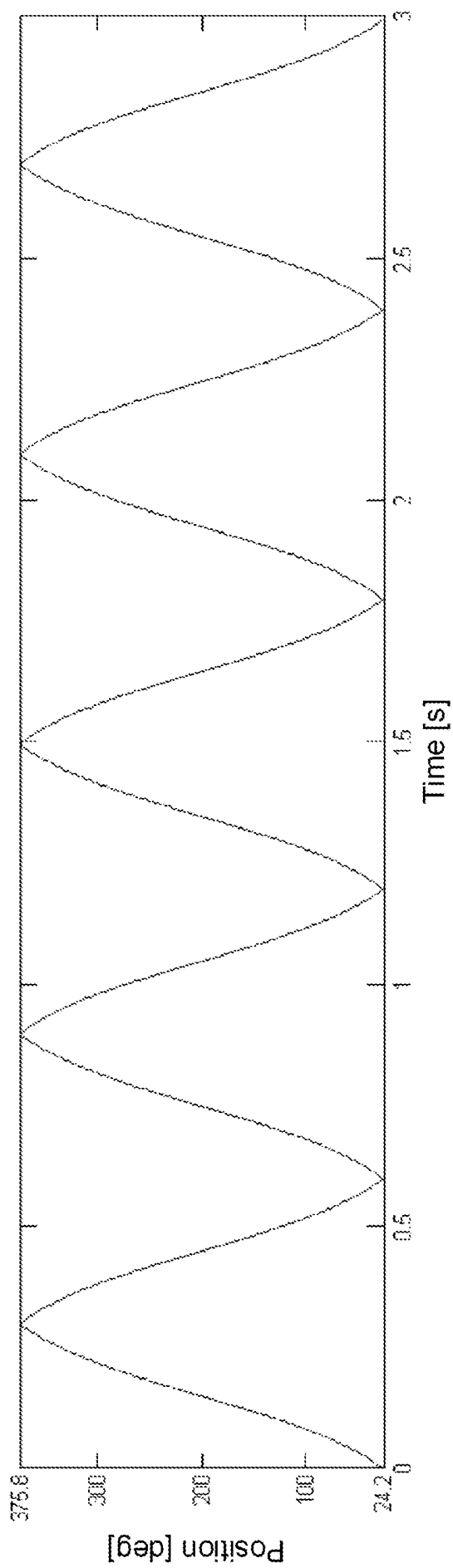

FIG. 5

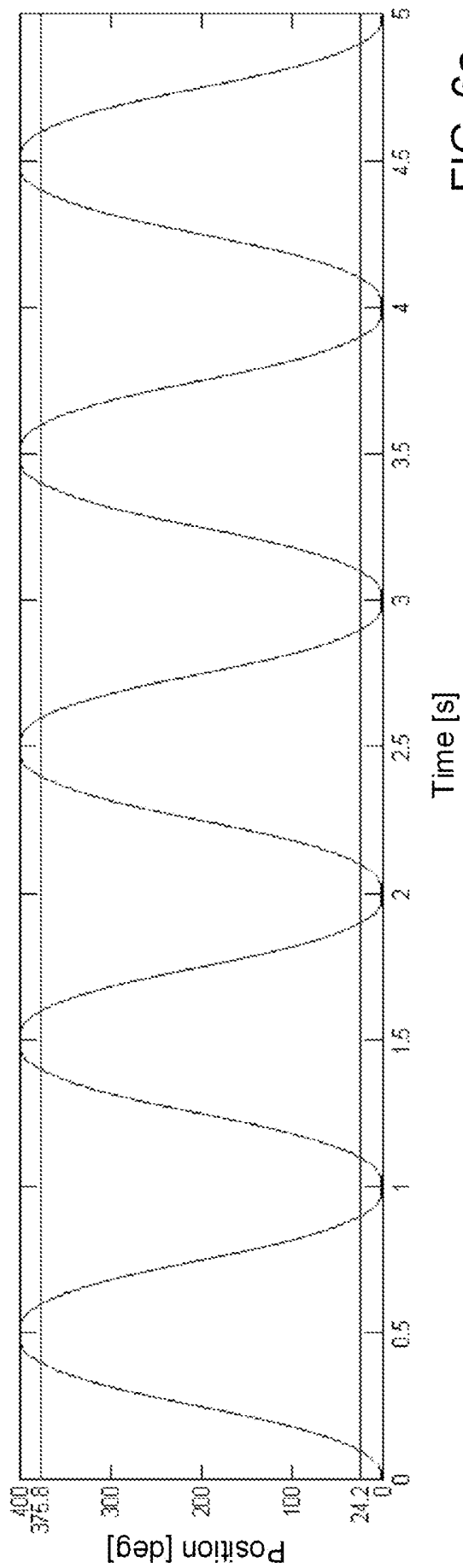

FIG. 6a

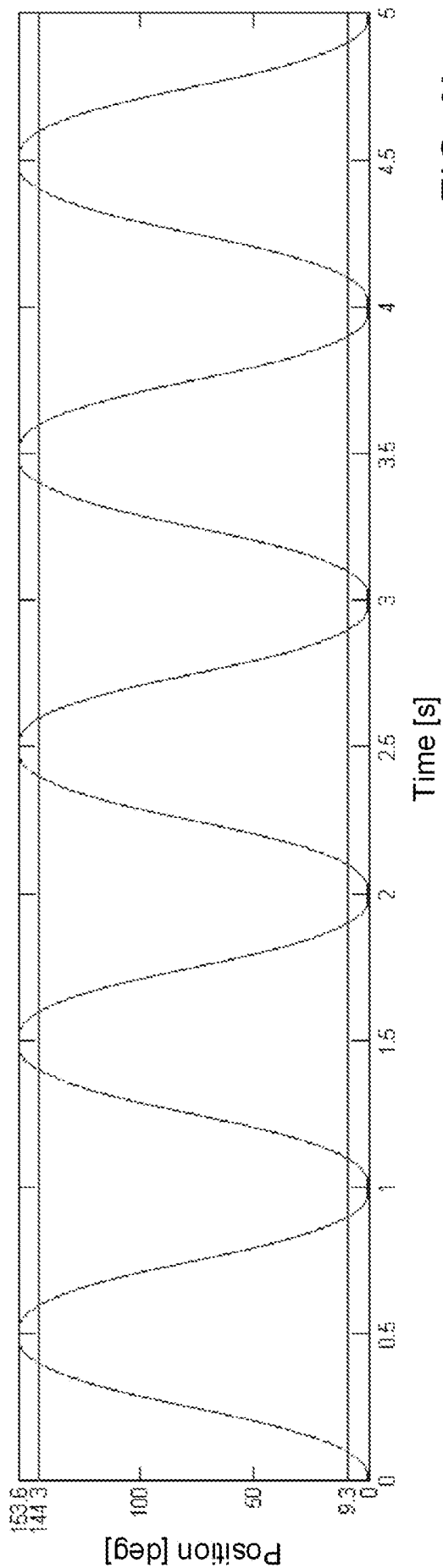

FIG. 6b

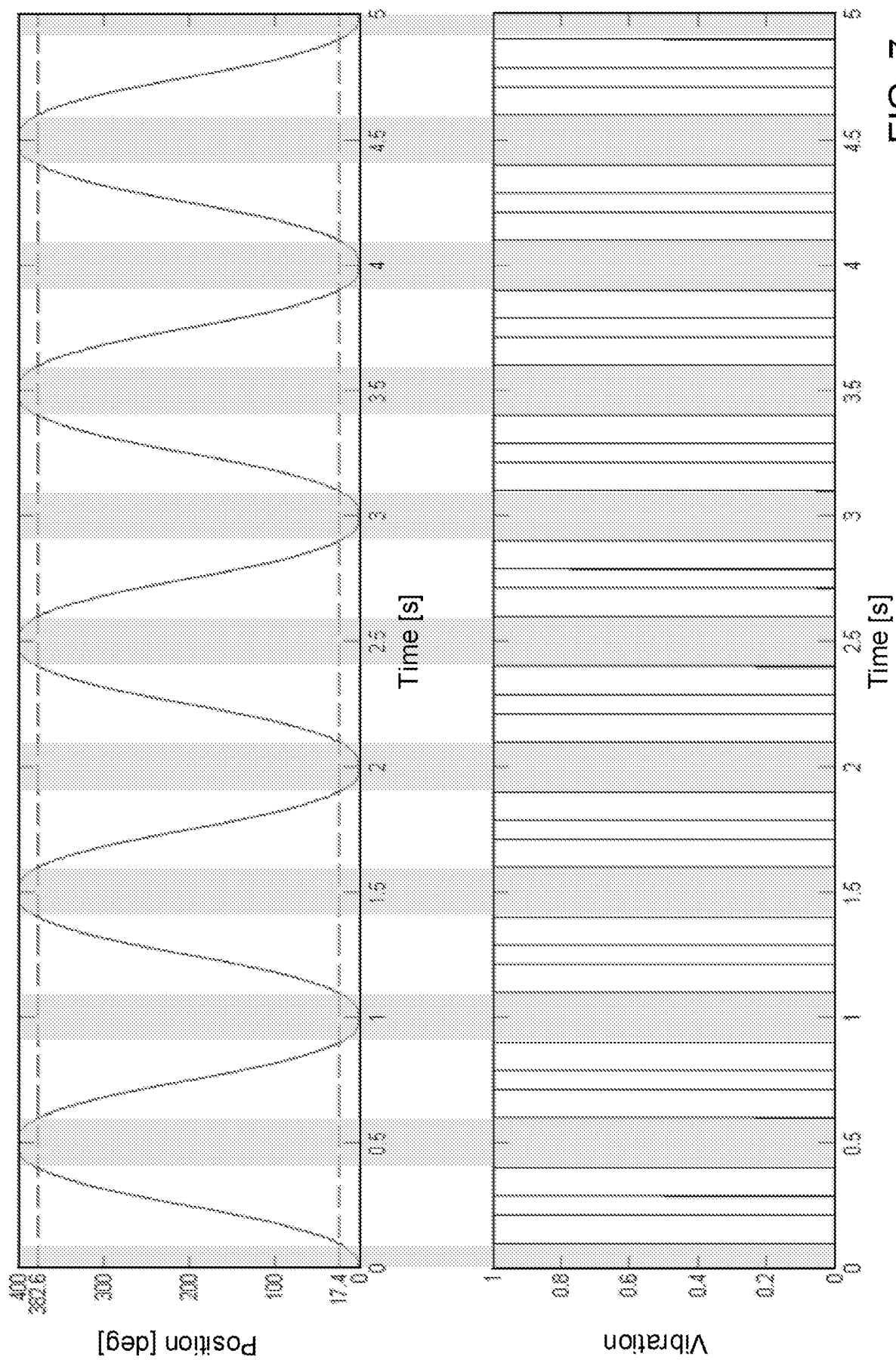

FIG. 7

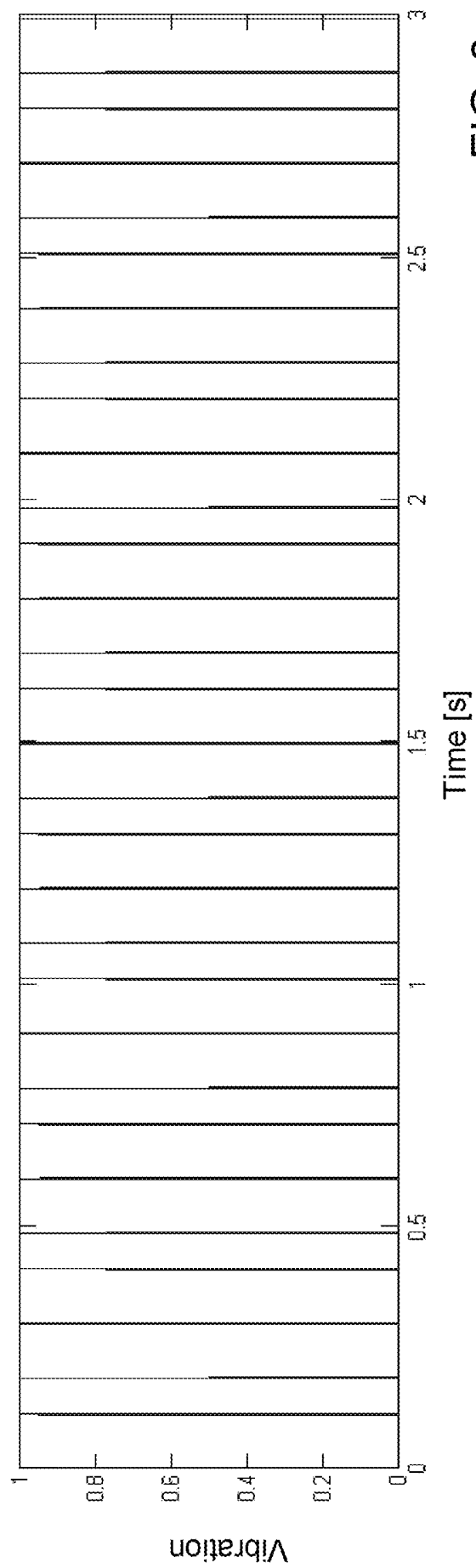
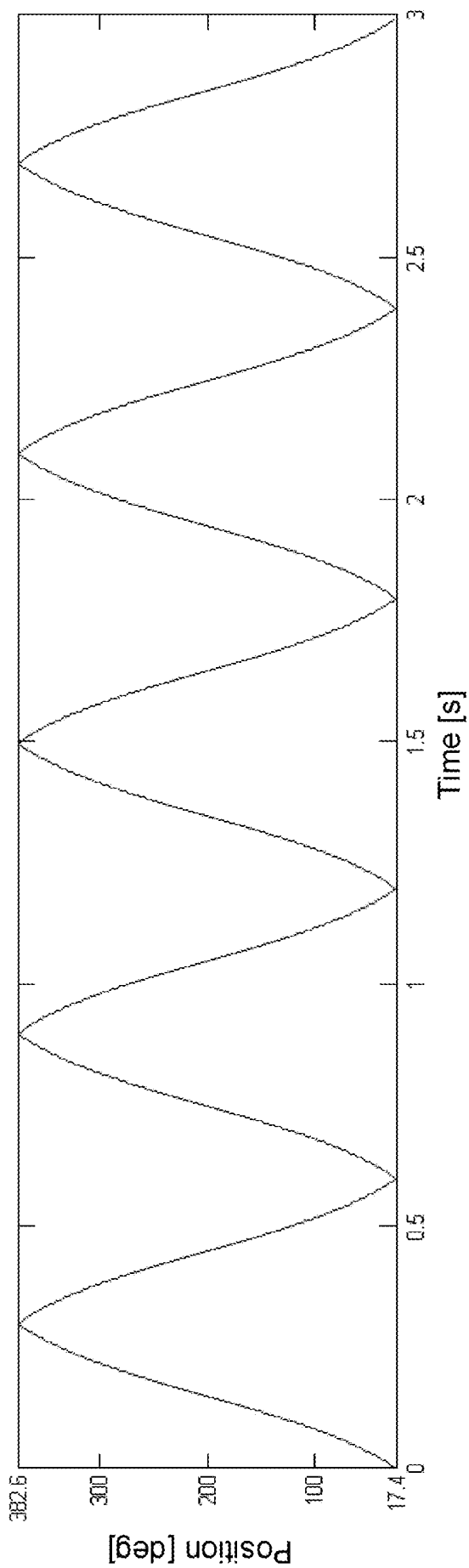
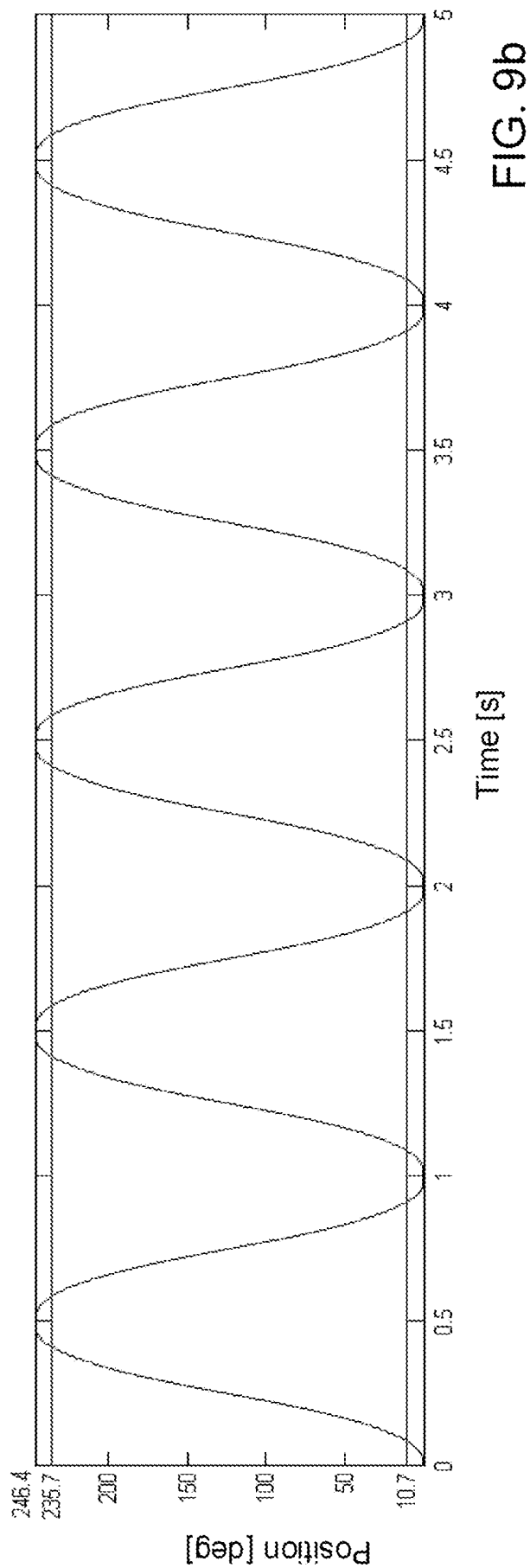
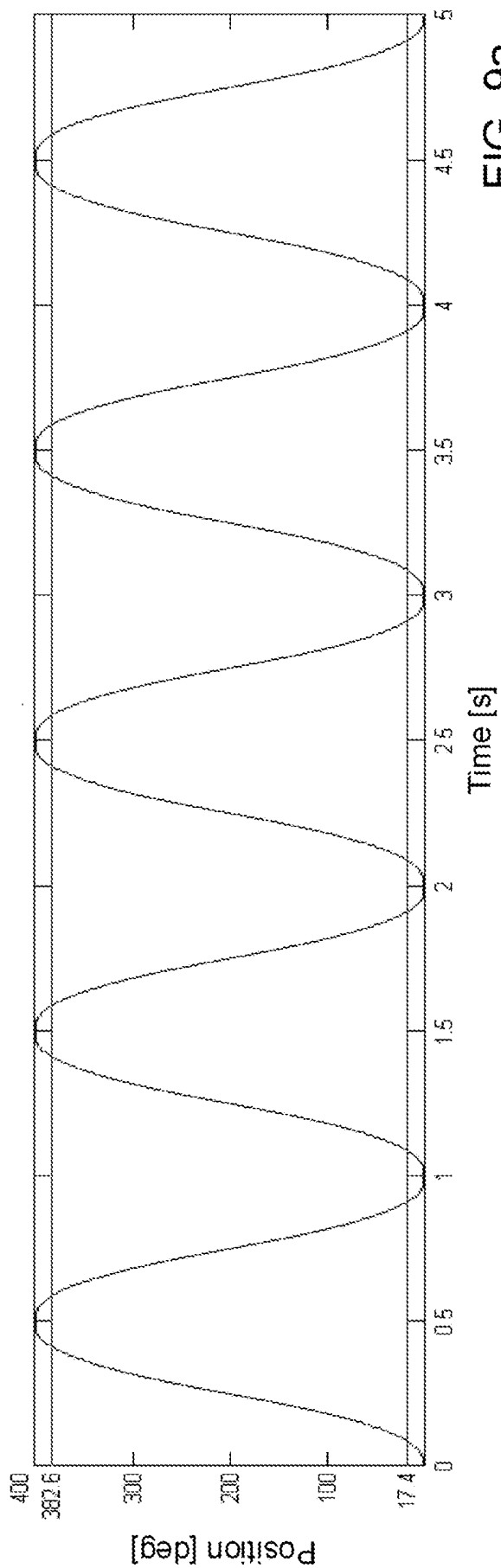

FIG. 8



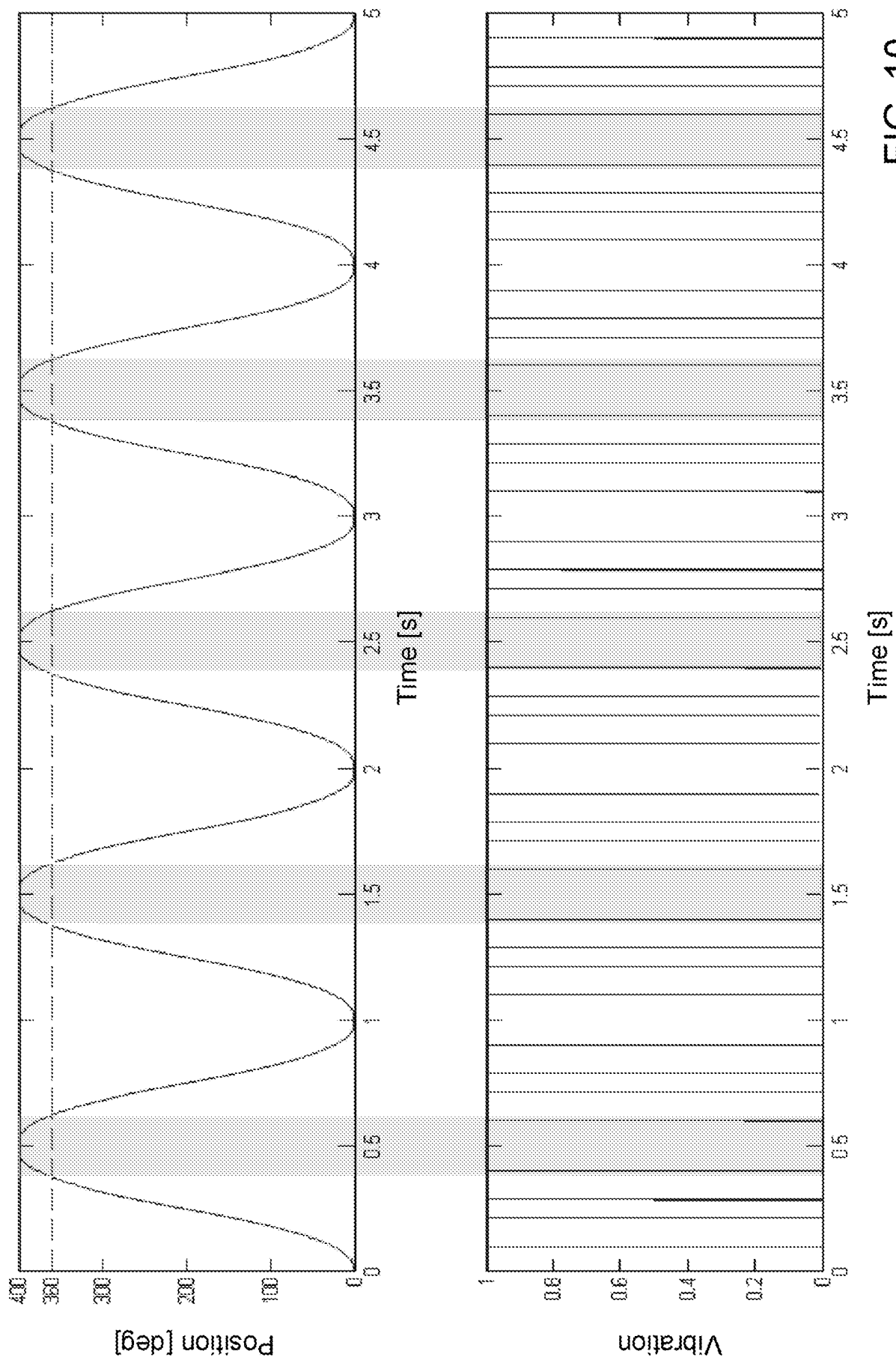

FIG. 10

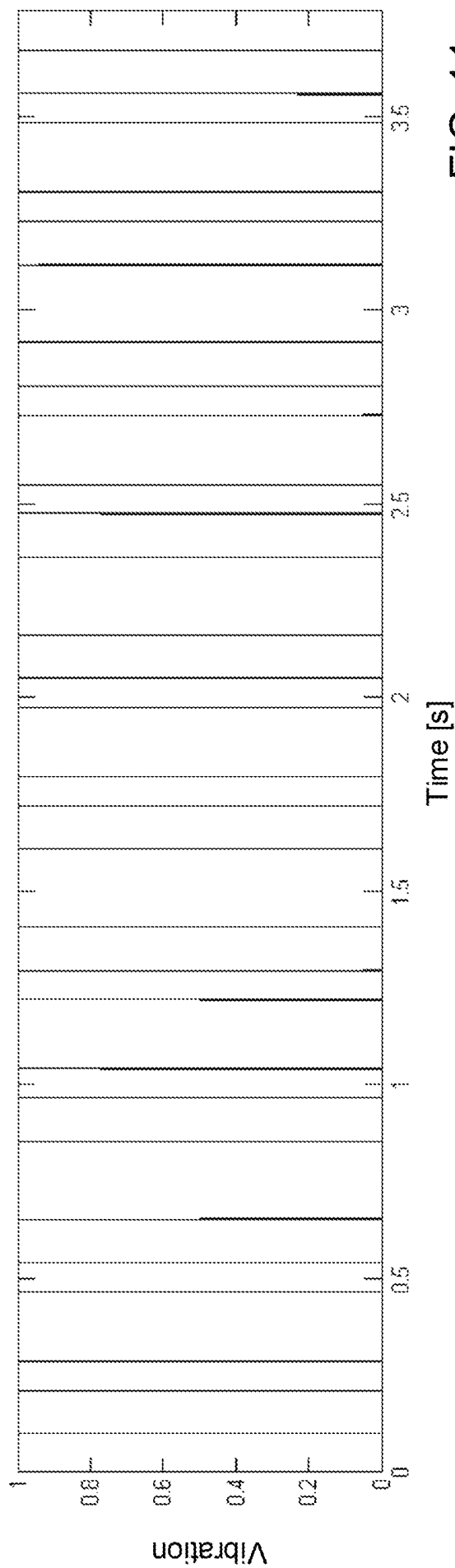
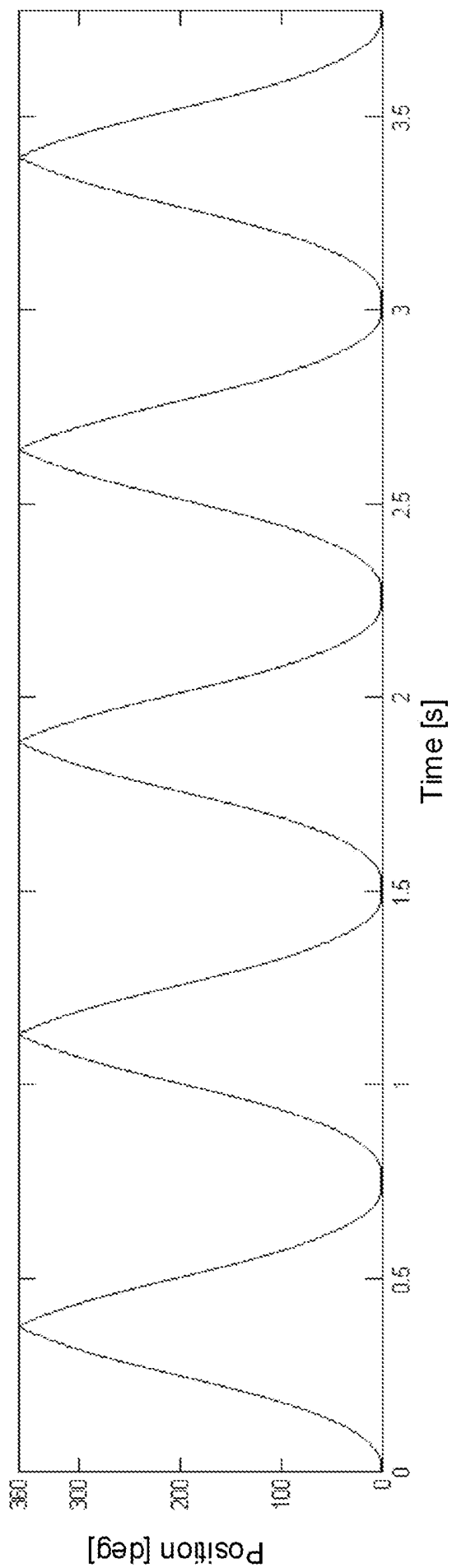

FIG. 11

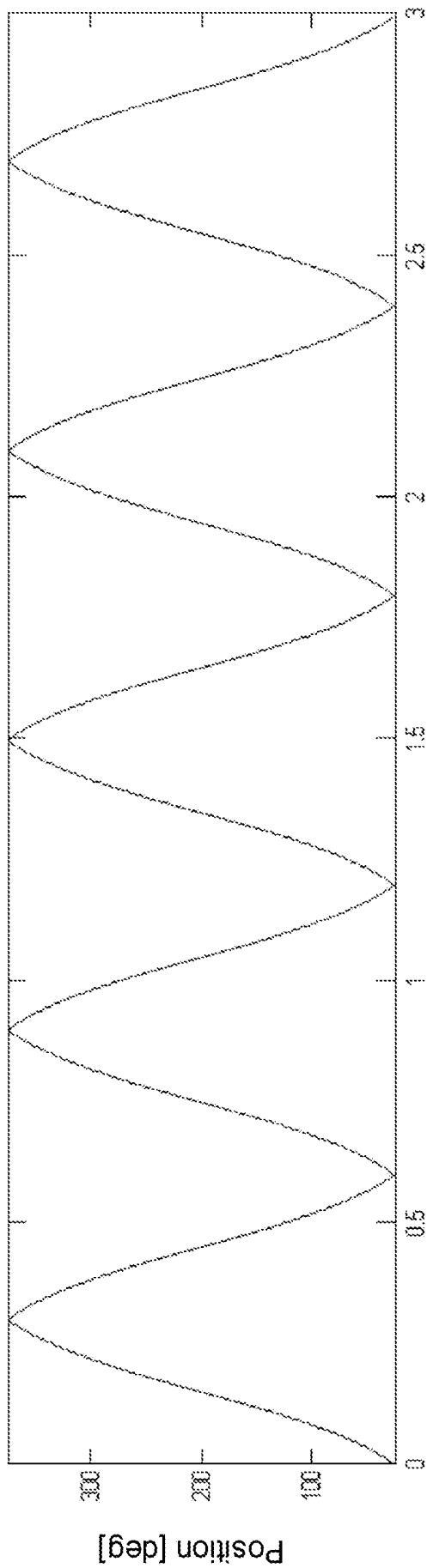

FIG. 12a

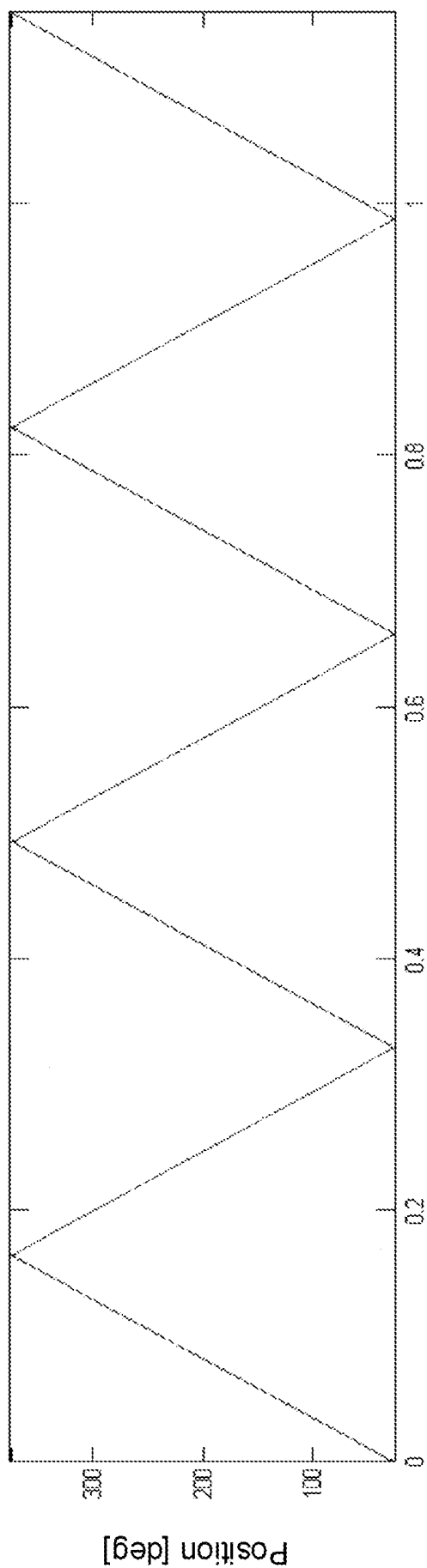

FIG. 12b

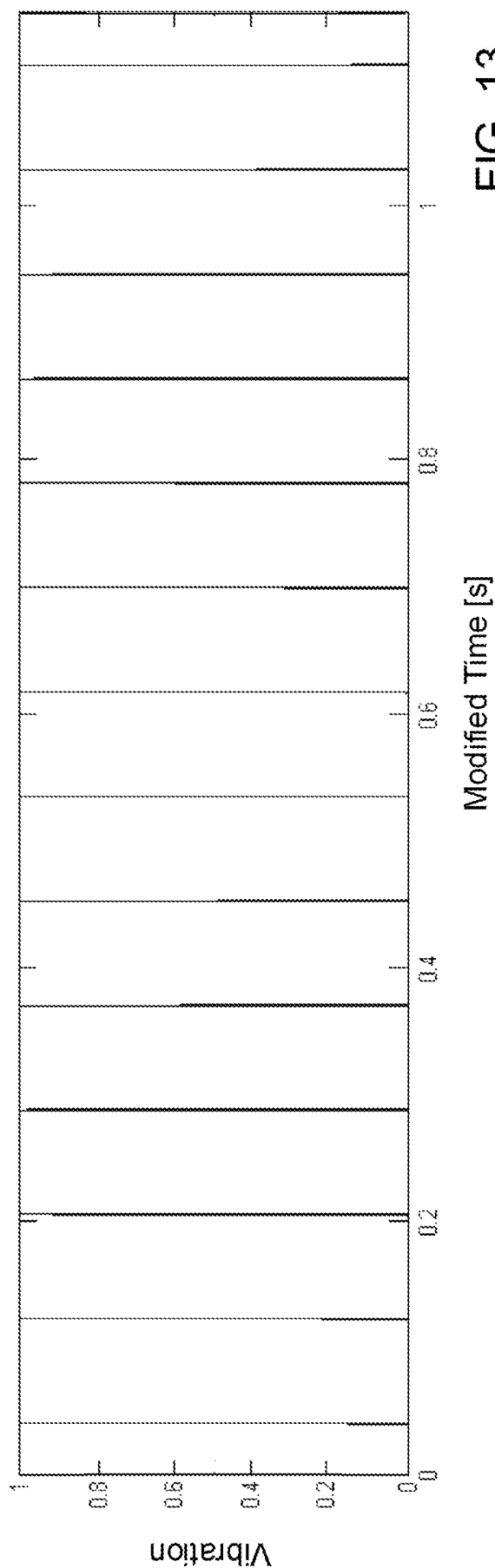
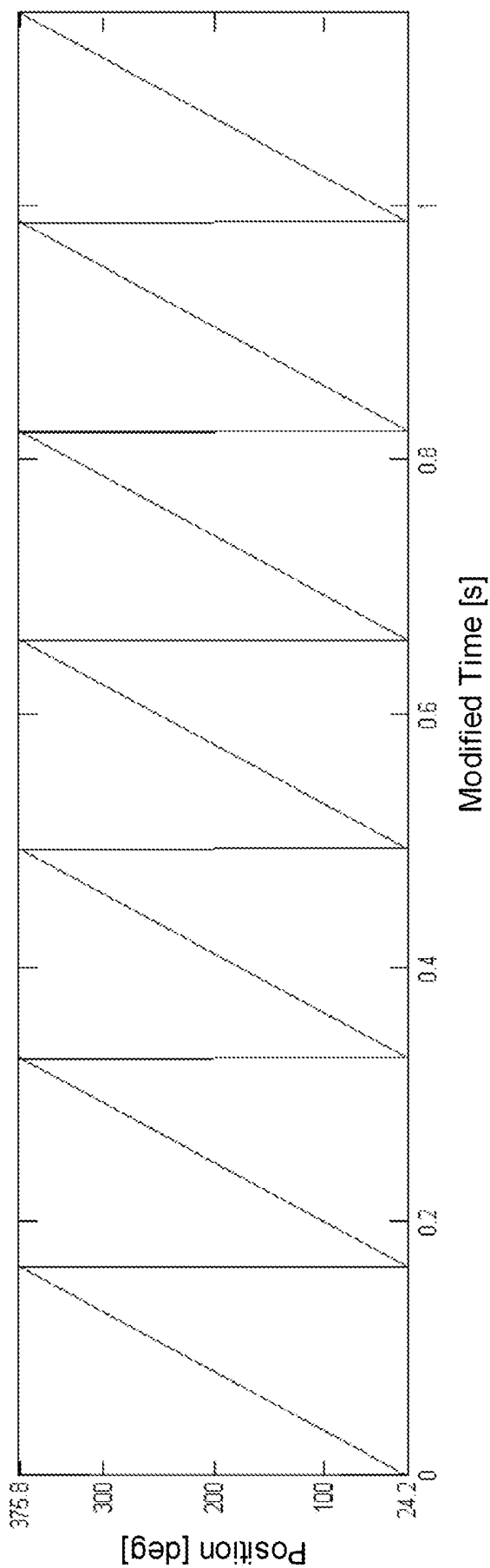

FIG. 13

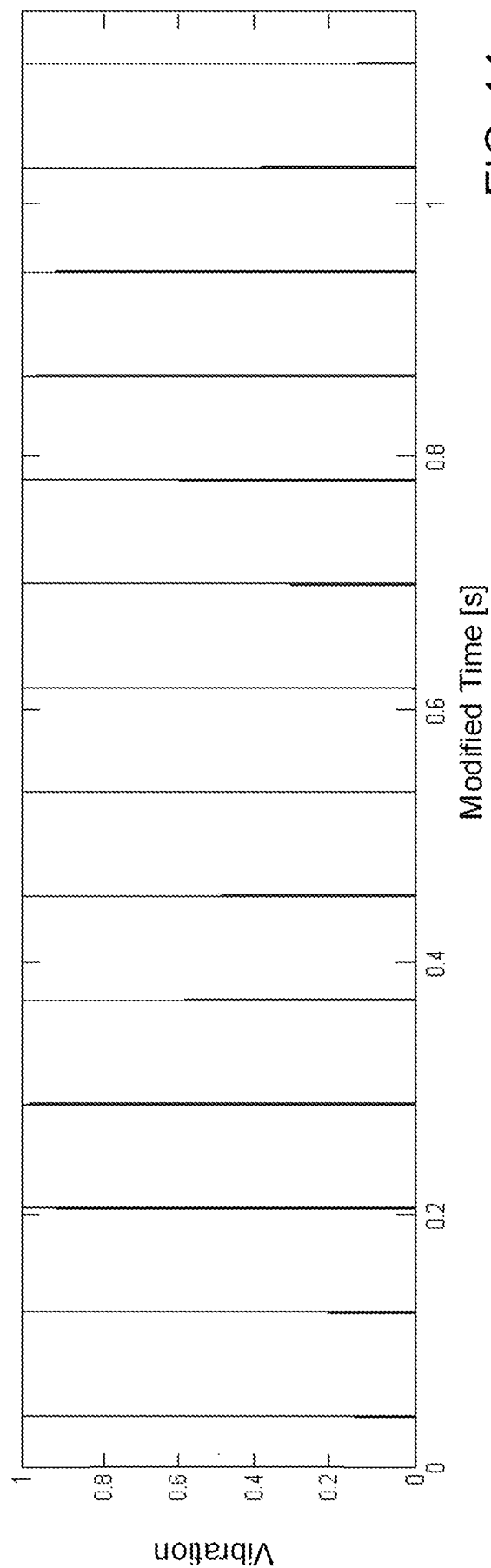
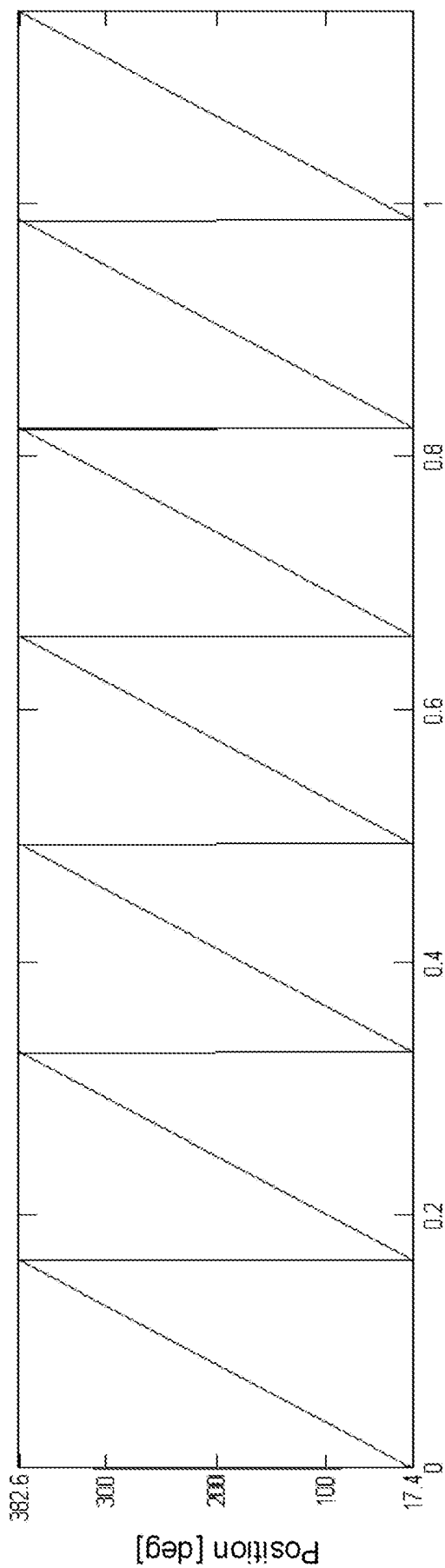

FIG. 14

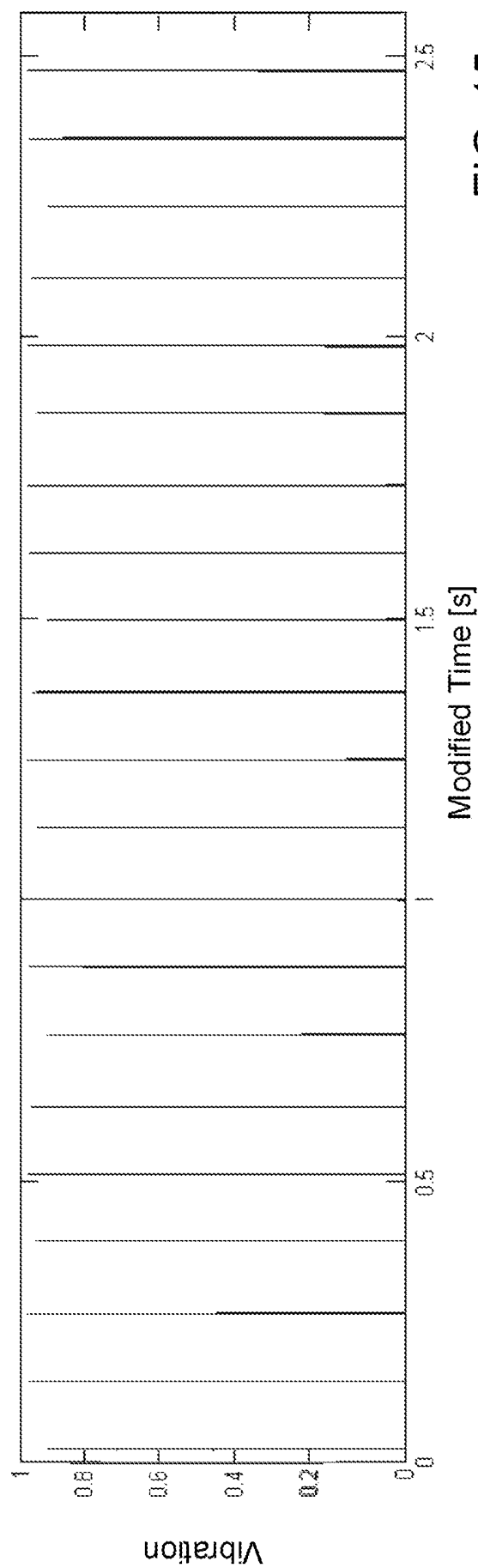
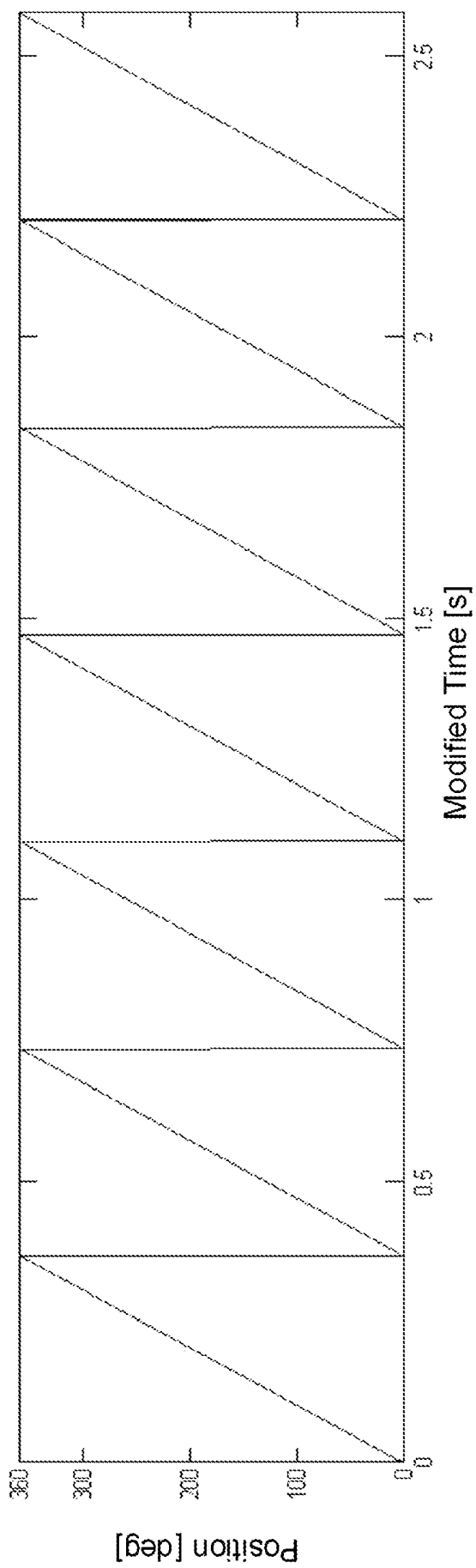

FIG. 15

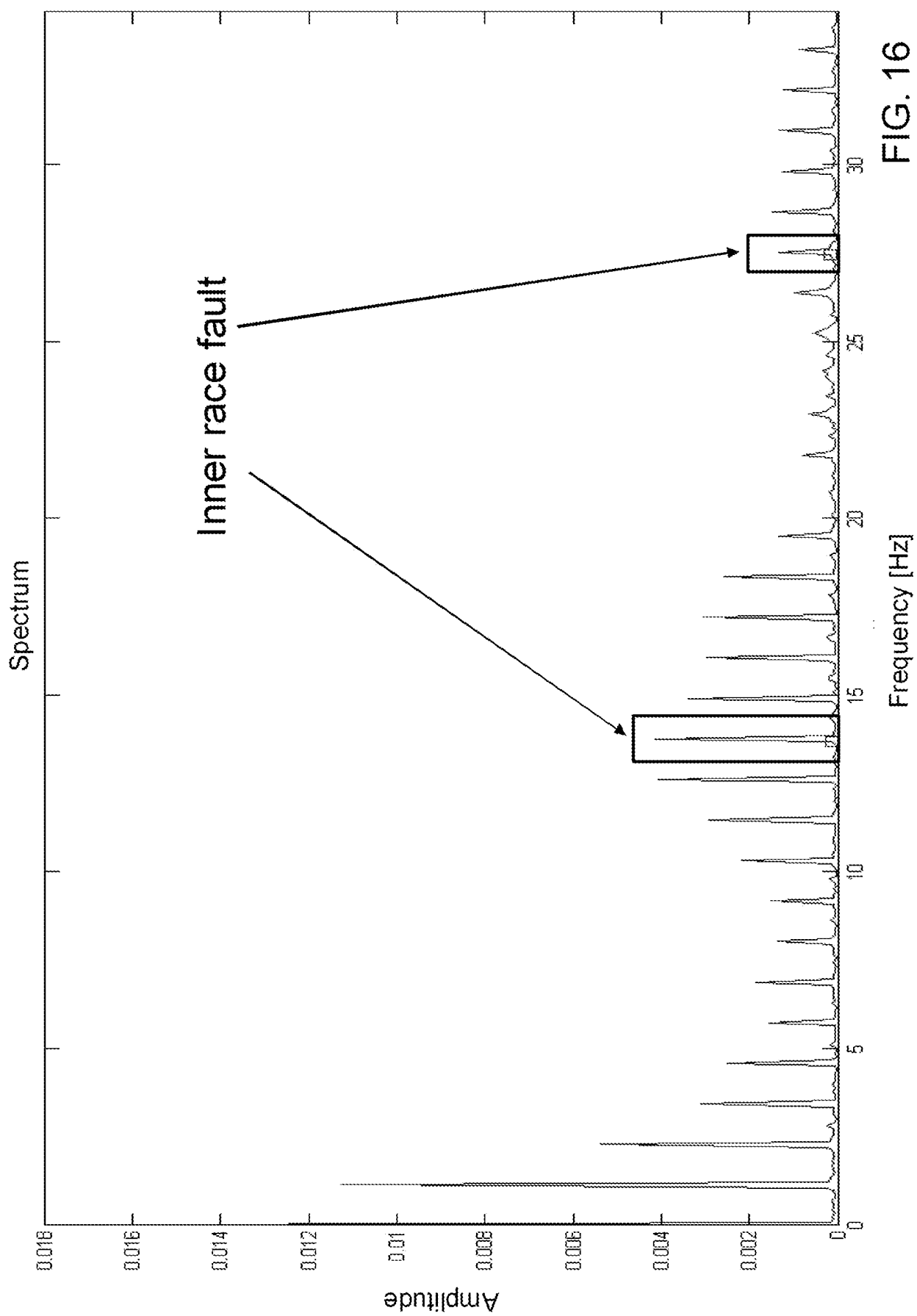

FIG. 16

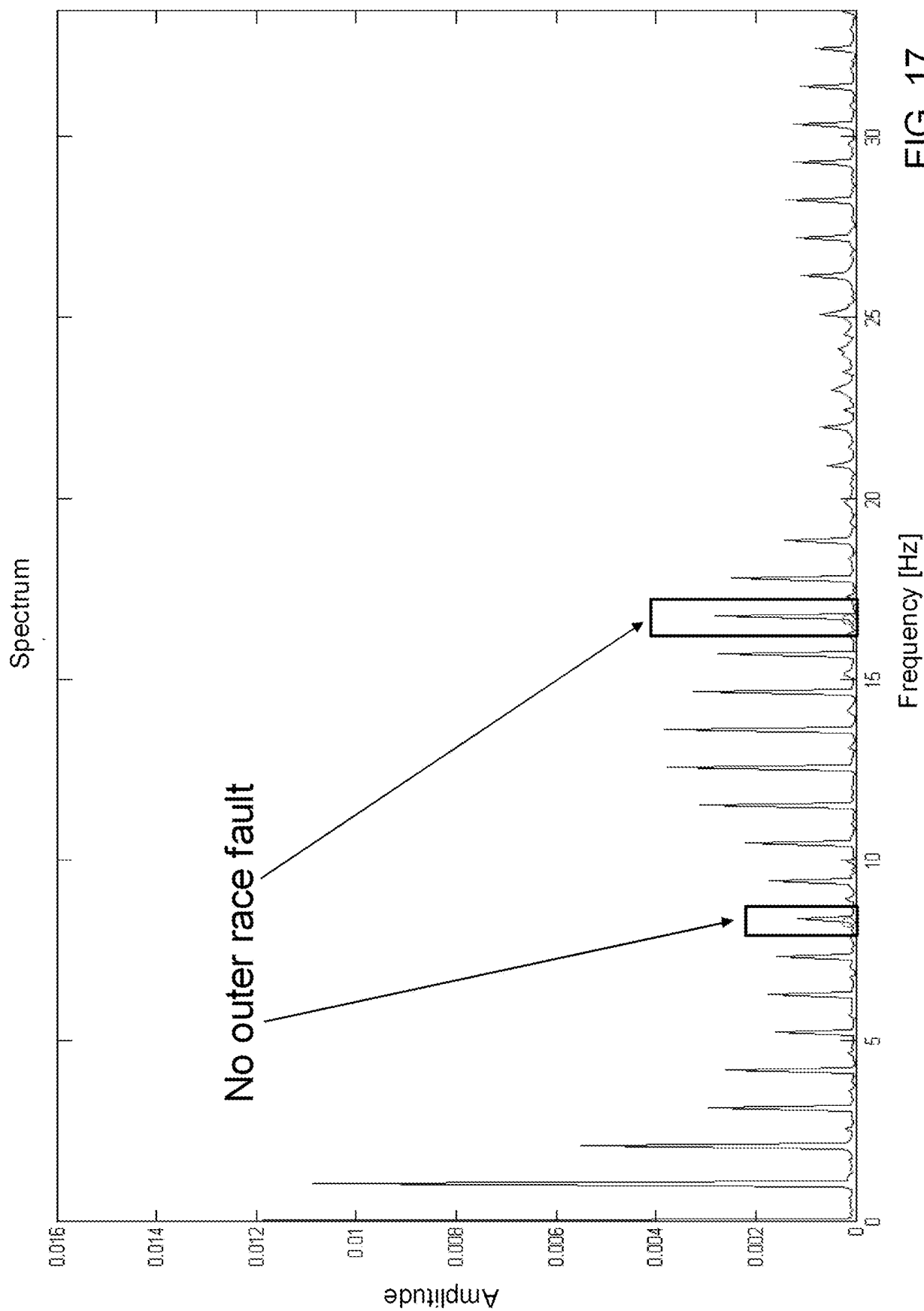

FIG. 17

INTERNATIONAL SEARCH REPORT

International application No

PCT/EP2010/052818

A. CLASSIFICATION OF SUBJECT MATTERINV. G01M13/04
ADD.

According to International Patent Classification (IPC) or to both national classification and IPC

B. FIELDS SEARCHEDMinimum documentation searched (classification system followed by classification symbols)
G01M

Documentation searched other than minimum documentation to the extent that such documents are included in the fields searched

Electronic data base consulted during the international search (name of data base and, where practical, search terms used)

EPO-Internal

C. DOCUMENTS CONSIDERED TO BE RELEVANT

Category*	Citation of document, with indication, where appropriate, of the relevant passages	Relevant to claim No.
X	US 5 511 422 A (HERNANDEZ WALTER C [US]) 30 April 1996 (1996-04-30) the whole document	1,3,4, 7-13
A	US 5 811 683 A (YOSHIOKA TAKEO [JP] ET AL) 22 September 1998 (1998-09-22) column 5, lines 10-40; figures 1,2,5,8,9	1

 Further documents are listed in the continuation of Box C. See patent family annex.

* Special categories of cited documents :

"A" document defining the general state of the art which is not considered to be of particular relevance

"E" earlier document but published on or after the international filing date

"L" document which may throw doubts on priority claim(s) or which is cited to establish the publication date of another citation or other special reason (as specified)

"O" document referring to an oral disclosure, use, exhibition or other means

"P" document published prior to the international filing date but later than the priority date claimed

"T" later document published after the international filing date or priority date and not in conflict with the application but cited to understand the principle or theory underlying the invention

"X" document of particular relevance; the claimed invention cannot be considered novel or cannot be considered to involve an inventive step when the document is taken alone

"Y" document of particular relevance; the claimed invention cannot be considered to involve an inventive step when the document is combined with one or more other such documents, such combination being obvious to a person skilled in the art.

"&" document member of the same patent family

Date of the actual completion of the international search

6 April 2010

Date of mailing of the international search report

14/04/2010

Name and mailing address of the ISA/

European Patent Office, P.B. 5818 Patentlaan 2
NL - 2280 HV Rijswijk
Tel. (+31-70) 340-2040,
Fax: (+31-70) 340-3016

Authorized officer

Prasse, Torsten

INTERNATIONAL SEARCH REPORT

Information on patent family members

International application No PCT/EP2010/052818

Patent document cited in search report	Publication date	Publication date	Patent family member(s)	Publication date
US 5511422	A	30-04-1996	AU 6627894 A	08-11-1994
			CA 2159920 A1	27-10-1994
			DE 69421393 D1	02-12-1999
			DE 69421393 T2	31-08-2000
			EP 0693176 A1	24-01-1996
			WO 9424537 A1	27-10-1994
US 5811683	A	22-09-1998	EP 0800072 A2	08-10-1997
			JP 3051911 B2	12-06-2000
			JP 9273979 A	21-10-1997