

OPEN ACCESS

Progress of the NA62 RICH detector

To cite this article: Massimo Lenti 2014 *JINST* **9** C01054

View the [article online](#) for updates and enhancements.

You may also like

- [Design, performance and perspective of the NA62-RICH](#)
M. Turisini
- [Physics beyond colliders at CERN: beyond the Standard Model working group report](#)
J Beacham, C Burrage, D Curtin et al.
- [Performance and advantages of a soft-core based parallel architecture for energy peak detection in the calorimeter Level 0 trigger for the NA62 experiment at CERN](#)
R. Ammendola, M. Barbanera, M. Bizzarri et al.

13th TOPICAL SEMINAR ON INNOVATIVE PARTICLE AND RADIATION DETECTORS
7–10 OCTOBER 2013
SIENA, ITALY

Progress of the NA62 RICH detector

Massimo Lenti¹

INFN Sezione di Firenze,

Via G.Sansone 1, 50019 Sesto Fiorentino (FI), Italy

E-mail: lenti@fi.infn.it

ABSTRACT: NA62 is the last generation Kaon experiment at CERN. Its main goal is to collect about $100 K^+ \rightarrow \pi^+ \nu \bar{\nu}$ events with 10% background. This implies to collect more than $10^{13} K^+$ decays with a background rejection factor better than 10^{12} . The challenging aspect of the experiment is the suppression of Kaon decays with branching ratios up to 10 orders of magnitude higher than the signal and similar experimental signature, such as $K^+ \rightarrow \mu^+ \nu$. To this purpose good PID (Particle IDentification) and kinematic rejection are required. Precise timing is also needed to correctly associate the π^+ with the parent K^+ in an high rate environment. A RICH (Ring Imaging Cherenkov) detector is proposed as PID element, to identify μ contaminating the π sample in the 15 – 35 GeV/c momentum range with inefficiency lower than 1% and to measure the arrival time with precision smaller than 100 ps. It will also be a key element for the NA62 trigger. A vacuum-proof cylindrical vessel with 4 m diameter, 17 m long, will be filled with Neon gas at atmospheric pressure. The Cherenkov light will be reflected by a mosaic of 20 hexagonal mirrors with 17 m focal length and collected by 2000 photomultipliers. The progress in the construction of the detector is described: the installation will start in January 2014, with completion foreseen in time for the first physics run of the NA62 experiment in the fall of 2014.

KEYWORDS: Particle identification methods; Cherenkov detectors; Timing detectors; Large detector systems for particle and astroparticle physics

¹On behalf of the NA62 RICH collaboration: G. Anzivino, A. Bizzeti, F. Bucci, V. Carassiti, A. Cassese, P. Cenci, R. Ciaranfi, V. Duk, J.R. Fry, E. Iacopini, M. Lenti, M. Pepe, M. Piccini.

Contents

1	The NA62 experiment	1
2	The NA62 RICH detector	3
3	The mirror system	3
4	The photomultipliers	4
5	Test beam with a RICH prototype	6
6	Conclusions	6

1 The NA62 experiment

Kaon physics has been very important in the history of Particle Physics as a tool to discover new phenomena like parity and CP violation but also as a probe of new physics (charm and top masses). At present Kaon decays with a Pion and a Neutrino-Antineutrino pair are considered the “golden channels” to have access to new physics above the TeV scale. Their branching ratio can be calculated in the framework of the Standard Model with a precision of 10% thanks to isospin symmetry and in particular for the charged Kaon decay it is predicted to be [1]:

$$BR(K^+ \rightarrow \pi^+ \nu \bar{\nu}) = (7.81 \pm 0.75 \pm 0.29) \times 10^{-11} \quad (1.1)$$

where the first error is due to uncertainties on the input parameters and the second one to long distance corrections. The high sensitivity for new physics has the price of a very small branching ratio. The measurement by the Brookhaven E787/E949 experiments is based on few signal candidates [2]:

$$BR(K^+ \rightarrow \pi^+ \nu \bar{\nu}) = (1.73_{-1.05}^{+1.15}) \times 10^{-10} \quad (1.2)$$

The difficulty for this measurement relies not only in its very low probability but also in its experimental signature: a charged track and nothing else.

The NA62 experiment at CERN was proposed [3] to collect about 100 signal events with a 10% background. The NA62 experiment will be located in the CERN North Area in the ECN3 cavern, previously used by the NA48 experiment, some parts of which will be recycled. The primary beam, 400 GeV/c momentum Protons from the SPS accelerator, will impinge on a beryllium target producing a secondary charged beam that will be collimated and focused in a 100 m long beam line. This secondary beam will have 75 GeV/c momentum with a 6% fraction of positive Kaons. The Kaon momentum will be measured by a beam spectrometer made by three stations of silicon pixel detectors (GTK); Kaons will be identified thanks to a Cherenkov detector (KTAG). The Kaon decay region will be in vacuum and will comprise a Pion spectrometer made by four stations of

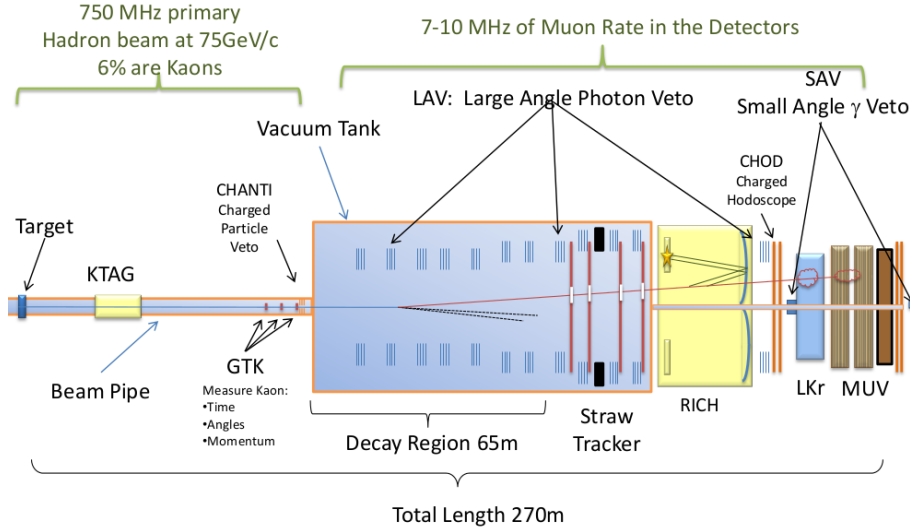

Figure 1. The NA62 experiment.

straw chambers with a dipole magnet providing a p_t kick of 270 MeV/c, followed by a RICH detector, an electromagnetic calorimeter and a Muon Veto system; several annular calorimeters will be present along the decay region to veto Photons from other Kaon decays. The total length of the experiment, from the target to the beam dump will be about 270 m. The particle rate seen by the detectors on the beam line will be 750 MHz, while the decay region detectors will afford a 10 MHz rate. A picture of the NA62 experiment can be seen in figure 1.

The most probable (63.4%) charged Kaon decay is with one Muon and a Neutrino (referred to as $K_{\mu 2}$) and can mimic the signal if the Muon is misidentified as a Pion. What is needed is a total suppression factor of 10^{-12} of the $K_{\mu 2}$ background to match the required accuracy of the measurement. Knowing the momentum modulus and direction of the charged Kaon before its decay and of the Pion (Muon) after the decay, the missing mass can be reconstructed:

$$m_{\text{miss}}^2 = (P_K - P_\pi)^2 \quad (1.3)$$

where P_K and P_π are the four-momenta of the Kaon and Pion, respectively, measured with the GTK and the Pion spectrometer; according to the (very detailed) simulation of the experiment, a $K_{\mu 2}$ suppression factor of 10^{-5} can be reached cutting on the missing mass. The usual way to distinguish between Pions and Muons is by means of the very different stopping power in matter, using a Muon Veto system: a suppression factor of 10^{-5} can be reached while below that level electromagnetic radiation showering and nuclear interactions make it impossible to separate Pions from Muons. A further 10^{-2} suppression is achieved by means of a RICH detector. At the offline level events are selected with a Pion momentum between 15 and 35 GeV/c where the simulation indicates the best compromise between signal acceptance and background rejection.

To reconstruct the missing mass it is necessary to match a track in the beam spectrometer, which sustains a 750 MHz track rate, with a track in the Pion spectrometer (10 MHz), a wrong matching introducing important tails in the missing mass distribution. To minimize the wrong

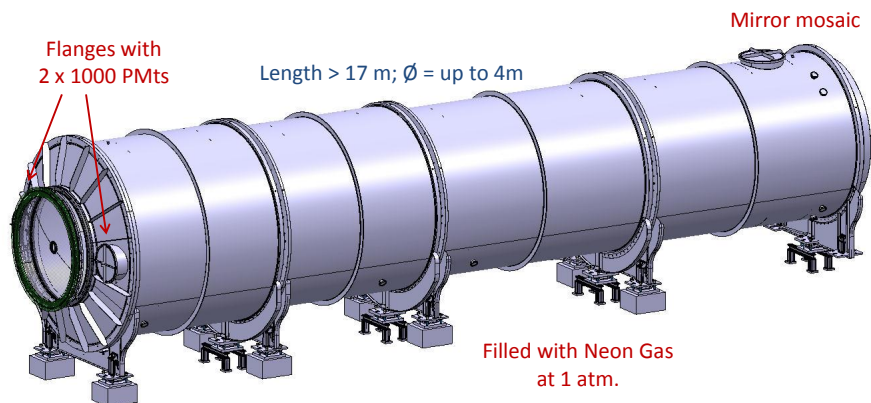

Figure 2. The NA62 RICH detector.

matching, a very good time resolution, of the order of 100 ps, is required both for the Kaon track (given by the GTK) and the Pion track (provided by the RICH).

2 The NA62 RICH detector

Pions and Muons must be separated in a momentum range between 15 and 35 GeV/c: this drives the choice of the Cherenkov radiator, which must have a radiation threshold a bit smaller than the lower momentum bound to maximize the separation capability. Neon gas at atmospheric pressure almost perfectly matches this requirement: the Cherenkov threshold for Pions is 12.5 GeV/c, which also guarantees full efficiency above 15 GeV/c. Neon has also a very small chromatic dispersion and very good transparency to UV light. On the other hand the very small index of refraction ($n - 1 = 62 \times 10^{-6}$) calls for a very long radiator to get enough Cherenkov Photons to be detected. The NA62 RICH detector will be made by a container (vessel) 17 m long. A drawing of the detector can be seen on figure 2.

The RICH vessel will be made in structural steel, divided into 4 cylindrical sections of different lengths and decreasing diameters (between 4 m at the beginning and 3.4 m at the downstream end). A conical cap at the upstream end will connect the RICH detector to the vacuum decay region and will have two protruding cylinders to lodge 2000 photomultipliers. An aluminum beam pipe, 157 mm in diameter, will cross all the RICH container to allow undecayed beam particles to pass undisturbed; thin aluminum entrance and exit windows will minimize the interactions of Kaon decay products with the detector.

The total RICH inner volume to be filled by Neon gas is 200 m³. The gas will be kept slightly above atmospheric pressure with a density stability better than 1% and a contaminants level well below 1%. Before introducing pure Neon, the RICH container will be first fully evacuated; when the detector will be full of Neon, it will be sealed.

3 The mirror system

The Cherenkov light emitted by a charged particle crossing the Neon gas will be focused into a ring by means of a spherical mirrors system. At the downstream end of the detector, 18 hexagonal

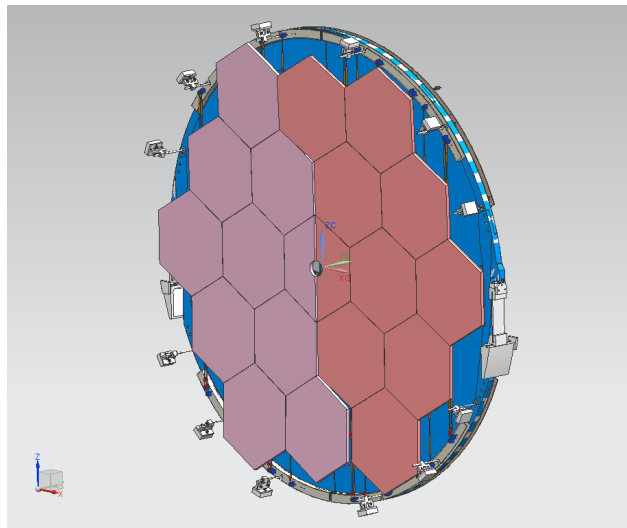

Figure 3. The NA62 RICH mirror system.

mirrors (700 mm wide, 25 mm thick, made of glass) and two special semi-hexagonal mirrors (close to the center, where the beam pipe will pass) will be located (see figure 3). All these mirrors have a focal length of 17 ± 0.1 (corresponding to the upstream end of the detector, where the photomultipliers will be located) and a reflectivity in excess of 90% over a wavelength range 195-650 nm. The high optical quality is guaranteed by a D_0 parameter smaller than 4 mm (the D_0 of a spherical mirror is defined as the diameter of the smallest circle where 95% of the reflected light is collected, produced by a point source placed in the center of curvature). All the mirrors will be supported by a panel which must be as light as possible to minimize particle interactions. An aluminum honeycomb panel, divided into two halves and 50 mm thick, will do the job. Each hexagonal mirror will have a 10 mm wide hole in the rear surface (the part not optically prepared): an aluminum dowel will be inserted in this hole to support the mirror. The dowel will be connected to the support panel by means of a hollow aluminum cone. The mirror alignment will be achieved by means of two aluminum ribbons, 200 μm thick, 10 mm wide, pulling horizontally the mirror at $\pm 45^\circ$ with respect to the vertical direction; a third vertical ribbon will be used to avoid the mirror rotation. The pulling ribbons will be moved with micrometric precision by means of piezo-electric motors, with a maximum force of 20 Newtons and a maximum range of 35 mm. A picture of the alignment system for a single mirror can be seen on figure 4.

4 The photomultipliers

The RICH detector will be equipped with 1952 single anode photomultipliers (PMTs), divided into two parts (corresponding to the two halves in which the mirror system is split, in such a way to avoid the shadow induced by the presence of the beam pipe) and positioned in the focal plane of the mirror system (see figure 2). A compromise between good quantum efficiency, small size, good time resolution and cost led to the choice of the Hamamatsu R7400U-03 photomultiplier [4]. Its cylindrical shape has a diameter of 16 mm with a 8 mm diameter active area. This device is made

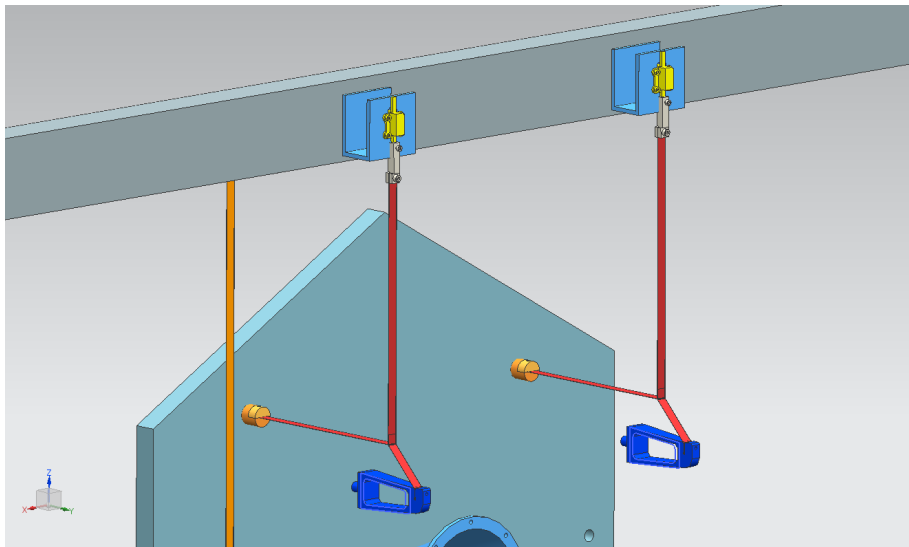

Figure 4. The alignment system for a single mirror. The piezo-electric motors, on top of the picture, are outside particles acceptance. The pulling ribbons have three branches: one attached to the rear surface of the mirror, one at the piezo-electric motor and the last one is used to transform the movement from vertical to horizontal. A third, vertical, ribbon is visible on the left of the picture; it is attached to one side of the rear face of the mirror to avoid its rotation.

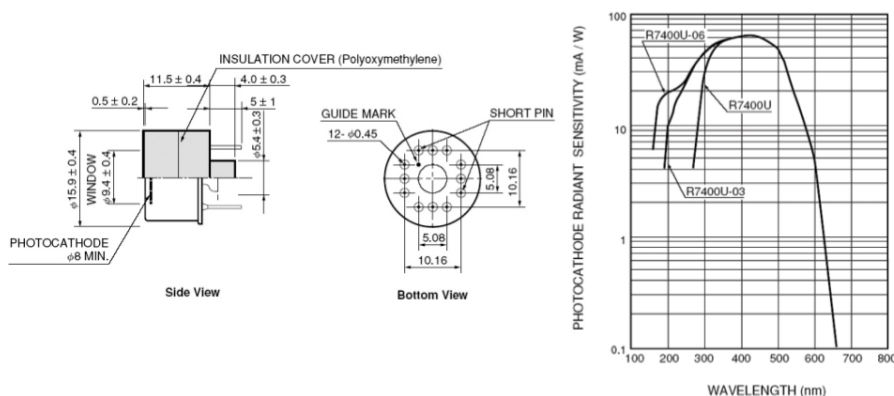

Figure 5. Left: geometrical dimensions of the Hamamatsu R7400U-03 photomultiplier [4]. Right: photocathode radiant sensitivity as a function of incident light wavelength for some Hamamatsu photomultipliers.

by 8 dynodes, with a gain of 1.5×10^6 at 900 volts. It has a UV-glass entrance window and a bialkali photocathode and it is sensitive to light with wavelength between 185 and 650 nm, with a peak around 420 nm, where about 20% quantum efficiency is achieved. At 900 volts the output for a single photoelectron is 240 fC, with a fast signal peaking at $200 \mu\text{A}$ or -10 V (over 50Ω); this signal has a typical rise time of 0.78 ns and a fall time of 1.6 ns, with a time jitter (FWHM) of 280 ps. A drawing with the photomultiplier dimensions and the response spectrum can be seen on figure 5.

The PMTs will be packed in a honeycomb structure with minimum distance of 18 mm. The light will be collected to the photomultiplier active area with a Winston cone 18 mm large at the

beginning and 7.5 mm large in front of the photomultiplier, 23 mm high, drilled in an aluminum disk separating the Neon gas contained inside the detector from the outside air where the PMTs will be positioned; a quartz window at the end of each Winston cone will guarantee gas tightness and light transparency. The reflectivity of the Winston cone will be improved by insertion of aluminized mylar foils on its inner surface.

The analog output of each photomultiplier will be digitized with a fast discriminator (the NINO ASIC [5]) operated in time over threshold mode. The LVDS (Low-Voltage Differential Signaling) output will be sent to a HPTDC (High Performance Time to Digital Converter [6]) embedded on a DAQ (Data Acquisition) board called TEL62. The RICH information will be used in the first level of the trigger of the NA62 experiment.

5 Test beam with a RICH prototype

The RICH project was validated with a strong R&D program based on a detector prototype with the same length (17 m) and radiator (Neon at atmospheric pressure), but much smaller in transverse dimensions (the vessel had an inner diameter of 600 mm), and equipped with only one spherical mirror (of circular shape, 500 mm in diameter) with a focal length of 17 m. The RICH prototype was installed in the CERN North Area ECN3 cavern.

In 2007 a first version of the prototype, equipped with 96 PMTs, was exposed to a 200 GeV/c momentum negative Pions beam. The average number of fired photomultipliers (hits) was 17 (due to the smaller acceptance given by the available number of PMTs) and the time resolution per event was measured to be 70 ps [7].

In 2009 an improved version of the prototype, equipped with 414 PMTs, was exposed to a positive Pions beam with tunable momentum between 15 and 50 GeV/c. Positrons were also present in the beam and they gave rise to an average number of 20 hits; Pions had an average number of hits between 7.5 at 15 GeV/c and 17.5 at 35 GeV/c momentum. The Cherenkov angle resolution was $70 \mu\text{rad}$ for 35 GeV/c momentum Pions with a time resolution of 60 ps. Some distributions can be seen on figure 6.

Pion-Muon separation versus momentum was measured in the following way: for each nominal momentum point two data samples were collected, one with Pions at the same momentum and another with Pions with the same velocity of nominal momentum Muons. A total Muon suppression between 15 and 35 GeV/c momentum (weighted with the Muon spectrum of the final experiment) was measured to be 0.7%, with the suppression at 35 GeV/c below 2% [8] as can be seen on figure 7.

6 Conclusions

The NA62 RICH design is very demanding and it has been validated with a strong R&D program. The RICH installation schedule foresees the vessel delivery by January 2014, the mirrors mounting in late spring and the photomultipliers installation in summer 2014. At the end of the summer 2014 the beam pipe will be inserted and the detector will be evacuated and then filled with pure Neon. In October 2014 the commissioning of the apparatus is expected, in time for the first physics run of the full NA62 experiment.

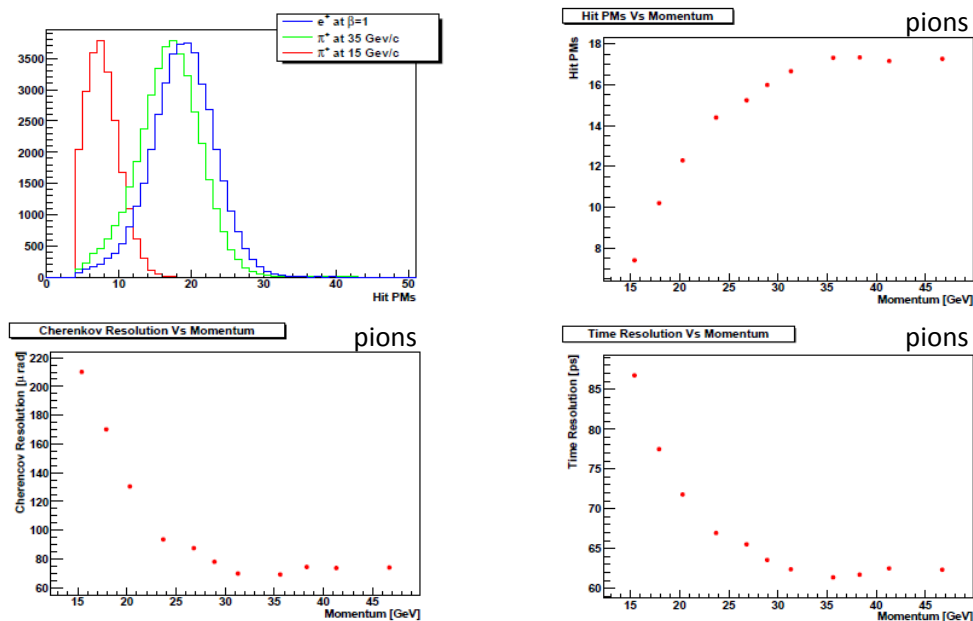

Figure 6. NA62 RICH prototype results from the 2009 test beam. Top left: distribution of fired photomultipliers (hits) for positrons and Pions at 15 GeV/c and 35 GeV/c momentum. Top right: number of hits as a function of Pion momentum. Bottom left: Cherenkov angle resolution versus Pion momentum. Bottom right: event time resolution versus Pion momentum.

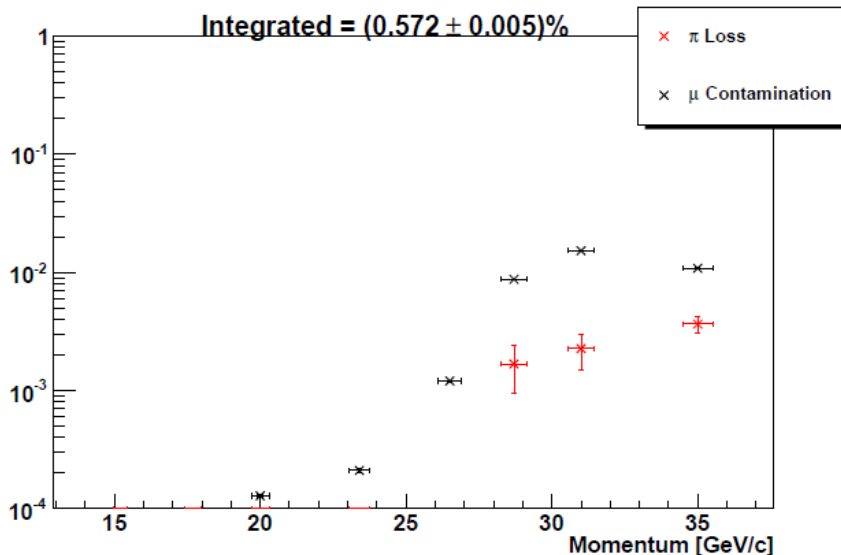

Figure 7. NA62 RICH prototype results from the 2009 test beam: Muon suppression and Pion loss probability versus momentum. The integrated Muon suppression, weighted with the final experiment Muon spectrum is indicated on top of the figure; taking into account some systematic errors, a conservative Muon suppression of 0.7% is quoted in the text.

References

- [1] J. Brod, M. Gorban and E. Stamou, *Two-loop electroweak corrections for the $K \rightarrow \pi\nu\bar{\nu}$ decays*, *Phys. Rev. D* **83** (2011) 034030.
- [2] A. V. Artamonov et al., *New measurement of the $K^+ \rightarrow \pi^+ \nu\bar{\nu}$ branching ratio*, *Phys. Rev. Lett.* **101** (2008) 191802.
- [3] NA62 collaboration, *Technical Design*, *NA62-10-07* (2010).
- [4] Hamamatsu Photonics K.K., <http://www.hamamatsu.com>.
- [5] F. Anghinolfi, P. Jarron, A.N. Martemiyarov, E. Usenko, H. Wenninger, M.C.S. Williams and A. Zichichi, *NINO: An ultra-fast and low-power front-end amplifier/discriminator ASIC designed for the multigap resistive plate chamber*, *Nucl. Instrum. Meth. A* **533** (2004) 183.
- [6] J. Christiansen, *HPTDC High Performance Time to Digital Converter*, CERN, Geneva, 2004, [Version 2.2 for HPTDC version 1.3](#).
- [7] G. Anzivino et al., *Construction and test of a RICH prototype for the NA62 experiment*, *Nucl. Instrum. Meth. A* **593** (2008) 314.
- [8] B. Angelucci et al., *Pion-Muon separation with a RICH prototype for the NA62 experiment*, *Nucl. Instrum. Meth. A* **621** (2010) 205.