



69th Conference of the Italian Thermal Engineering Association, ATI 2014

Design and preliminary operation of a gasification plant for micro-CHP with internal combustion engine and SOFC

N. Moriconi^a, P. Laranci^a, M. D'Amico^a, P. Bartocci^{*a}, B. D'Alessandro^a, G. Cinti^b, A. Baldinelli^b, G. Discepoli^b, G. Bidini^c, U. Desideri^c, F. Cotana^a, F. Fantozzi^c

^aCentro di Ricerca sulle Biomasse, Università di Perugia, Via G. Duranti – Strada S. Lucia Canetola s.n.c, 06125 Perugia, (Italy)

^bFuel Cell Laboratory, Università di Perugia, Via G. Duranti 67, 06125, Perugia (Italy)

^cUniversità di Perugia, Dipartimento di Ingegneria, Via G. Duranti 67, 06125 Perugia (Italy)

Abstract

A gasification plant was designed and built to test syngas production from biomass for electricity generation on microscale. The plant is mainly composed by a downdraft reactor, a gas cleaning section with a cyclone and a wet scrubber, a blower for syngas extraction and an ICE (Internal Combustion Engine, Lombardini LGA 340), equipped with an alternator. A small quantity of producer was also eventually sent to a button cell SOFC (Solid Oxide Fuel Cell) for preliminary characterization. The plant was tested in a preliminary experimental campaign to evaluate mass and energy balances and process efficiency. Woody biomass was used and the producer gas firstly passed through impingers bottles, to condense and measure tar concentration (according to CEN/TS 15439), and then the remaining uncondensed gas was analyzed with a micro-GC (Gas Chromatograph). The paper presents and discusses the results of the preliminary tests carried out.

© 2015 The Authors. Published by Elsevier Ltd. This is an open access article under the CC BY-NC-ND license (<http://creativecommons.org/licenses/by-nc-nd/4.0/>).

Peer-review under responsibility of the Scientific Committee of ATI 2014

Keywords: gasification; micro-CHP (Combined Heat and Power), biomass

* Corresponding author. Tel.: +39-075-585-3773; fax: +39-075-515-3321.
E-mail address: bartocci@crbnet.it

1. Introduction

Biomasses and wastes are renewable energy sources and their energy conversion does not increase the concentration of greenhouse gases in the atmosphere. State of the art technology for electricity production from biomass is direct combustion and thermal recovery in steam power plants, on a scale higher than 1 MWe, which implies high investment and operational costs (due to the complexity of the supply chain).

The production of electricity on a micro-scale, on the other hand, presents an easier authorization path and a simpler supply chain management, also increasing the possibility of using waste heat for CHP applications.

Gas turbines and ICEs are available on the market also on the microscale but require the conversion of biomass into a liquid or gaseous which, may be realized through pyrolysis and gasification processes [1-7].

Fixed bed downdraft technology is the most adopted and produces a gas having a low tar content and the investment cost of the plant is about 3,000 €/kWe [8-10].

However this technology is not completely mature, with few companies selling micro-CHP plants based on gasification process, with interesting payback of the investment and adequate installed capacity and running hours, to minimize risk assessment. Syngas use in engines and gas turbines, in fact, requires handling a gas with low LHV, tar, water and particulate contamination; moreover different fuel gases in the mixture will show different combustion behavior (flame speed, ignition delay, etc.). This turns into costly gas cleaning systems and combustion chamber modifications [11-23]. Coming to fuel cell applications with syngas from gasification and pyrolysis similar problems are encountered however, particularly for Solid Oxide Fuel Cell (SOFC) applications, tar presence may provide additional energy to the reformer and integrated cycles with gas turbines are particularly favourable [24-27].

From these premises a low cost a micro-scale gasification plant was designed and built at the Biomass Research Centre of the University of Perugia to be coupled to a small ICE or a bottom cell SOFC for experimental testing.

Syngas production capacity of the reactor was set to 17 kg/h and the reactor was considered with a downdraft technology.

Nomenclature

ICE	Internal Combustion Engine
SOFC	Solid Oxide Fuel Cell
GC	Gas Chromatograph
CHP	Combined Heat and Power
LHV	Low Heating Value
C	Carbon
C _{fix}	Fixed Carbon
H	Hydrogen
N	Nitrogen
O	Oxygen
AFR	Air to Fuel Ratio
I/O	Input/Output

2. Materials and methods

2.1. Plant design

The downdraft reactor was designed to supply a producer gas to be used in a Lombardini LGA 340 ICE, adapted for Liquefied Petroleum Gas (with a nominal power of about 6 kWe).

The electric power output for the Lombardini ICE, when fuelled with producer gas is about 3 kWe. A producer gas LHV (Low Heating Value) of 3 MJ/kg and gas mass flow of 17 kg/h was assumed.

The biomass composition shown in table 1 was considered to determine the air needed for the gasification process. Biomass elemental analysis (and biomass fixed carbon: C_{fix}) for a wood chip sample were derived from the Biomass Research Centre Laboratory database.

Table 1. Elemental analysis of wood chips (dry basys)

Element	Letter	Weight ratio
C	p	0.41
C_{fix}	x	0.14
H	q	0.07
N	/	0.03
O	r	0.49

Air to fuel stoichiometric ratio (AFR_{stec}) is given by the following equation [28]:

$$AFR_{stec} = 0.3 * \left[\frac{p*8}{3*0.233} + (8 * q - r) * \frac{1}{0.233} \right] = 5.0 \quad (1)$$

The letters indicated in equation 1 correspond to chemical elements mass fraction and are reported in table 1. Air to fuel stoichiometric ratio (AFR_{stec}) is equal to 5.0, assuming an equivalence ratio of 0.3 because typical values are comprised between 0.25 e 0.35 [28-29], considering that biomass enters the gasifier at 15% moisture content.

2.2. Plant layout

The layout of the gasification plant is presented in figure 1, it is composed by a down draft reactor, a cyclone, a scrubber to condense gasification tar, a blower to feed producer gas to the ICE. Producer gas can be fed to a burner, or to the internal combustion engine, or alternatively it can pass through a tar sampling line (based on CEN/TS 15439) and then it can be fed to a button cell SOFC. In preliminary tests the scrubber was filled with vegetable oil (sunflower oil), because it showss a higher efficiency in tar absorption, with respect to water [12]. Moreover the mixture of tar and oil could be fed to an ICE, increasing the production of electrical energy.

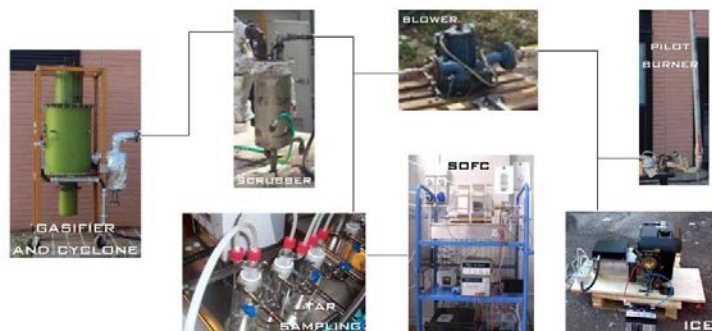

Fig. 1. Gasification plant layout

Biomass feeding system is based on a hopper, that works in batch conditions with a capacity of one charge per hour. Air flow regulation is carried out by an inverter, to control the blower which is at the outlet of the gasification plant and keeps the reactor below atmospheric pressure. Air is provided above the throat through 4 holes and 4 stainless steel pipes which enter the holes for a depth of 8 mm.

The low cost downdraft gasifier was designed according to the criteria adopted in [30]. The body of the reactor is

realized in high density ($2,340 \text{ kg/m}^3$) refractory cement "CALDE CAST M30" and its negative shape was initially designed and realized using teflon pipes and copper pipes to realize air inlet nozzles and thermocouples sites. The oxydation zone is situated in the throath of the reactor, realized using two cylinders made in teflon, that were eventually conically shaped. Once the mold was completed, the cement was inserted between two concentric cylinders. The external cylinder was made of iron, the internal was made of teflon. The hopper and the tank for ashes storage, have been also realized in iron C30.

The space between the refractory cement and the external cylinder was filled with Sibral ceramic fiber. The skid to support the reactor, was realized with commercial square tubes (40 x 40 mm) with a thickness of 2 mm. The grate positioned at the base of the reactor is a steel mesh, and is composed by three layers to decrease the square holes dimensions so also fine biomass can be used.

Figure 2 shows the mold together with the final reactor and the skid that supports it and its section.

The main dimensional parameters for the reactor were calculated assuming a specific consumption of biomass equal to 1.250 kg/h m^2 [31], referred to the surface of the grate. Figure 2c shows a section of the gasifier.

Cyclone design focused on the elimination of particles with diameter higher than $10 \mu\text{m}$ and was performed according to [32] and adjusted considering the dimensions of pipes available on the market.

The cyclone was realized in stainless steel with thickness of 2 mm. In correspondence of the lower section a plug is positioned to permit the removal of particulate matter, separated from producer gas flow.

During the preliminary tests presented in this paper a scrubber consisting of a vertical cylinder was used, made of AISI-304 stainless steel. Gas is inserted below a column of vegetable oil, that occupies about one third of the cylinder height (220 mm), thanks to the depression produced by the blower, the producer gas gurgles through this cooling liquid and condense tar vapors.

In the vegetable oil a submerged copper tube coil is connected to a refrigerator, so that the vegetable oil is continuously cooled. The scrubber was eventually modified, inserting a Venturi pipe at the inlet to improve gas cooling and the mixing of tar and oil (figure 2d).

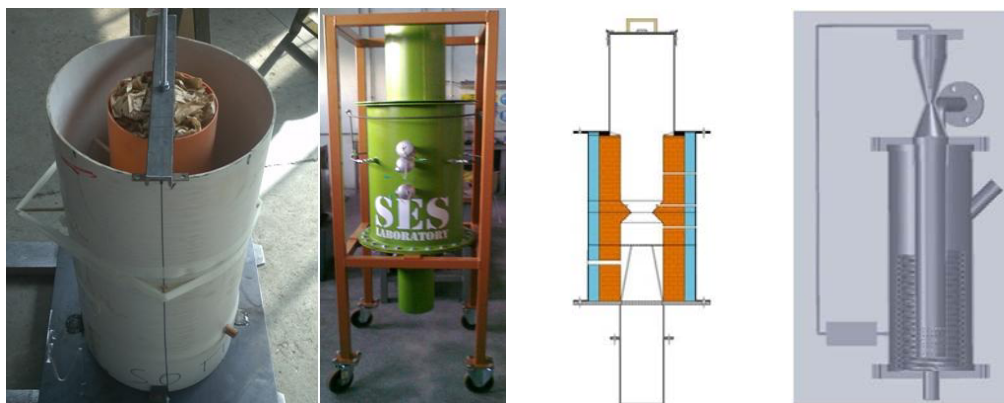

Fig. 2. (a) Gasificator mold; (b) reactor assembly; (c) reactor section; (d) Venturi scrubber

To calculate the scrubber efficiency tar concentration before and after the scrubber was measured through a tar sampling line, according to standard CEN/TS 15439 [33].

The gas exiting the tar sampling line is analysed using a micro-GC (GC Varian 3800). The control system of the gasification plant consists of a notebook with PCMCIA adaptator, connected to the National Instrument 6024E board. The board is connected to shielded I/O (Input/Output) connector block model SCB-68, produced also by National Instruments. Three K-type thermocouples monitor pyrolysis temperature, oxidation temperature and gasification zone temperature. The blower rotational speed is varied by an Omron inverter and controlled by a software, realized in Labview environment (in figure 3 the front panel is shown). Temperatures are monitored in the

most significant zones of the plant, also an oxygen sensor was introduced to regulate automatically the blower frequency.

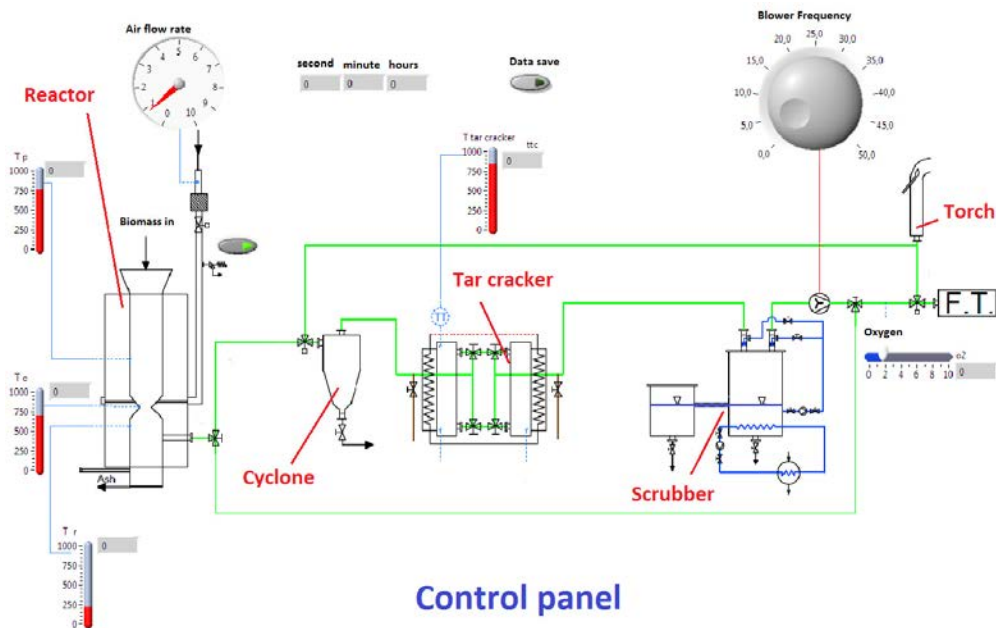

Fig. 3. Gasification plant control panel

3. Results of experimentation

3.1. Gasifier

Preliminary tests had the objective to determine producer gas composition and heating value, efficiency of tar removal as a function of time, using vegetable oil as an absorbing fluid. Wood chips were used as input biomass to the gasifier and the scrubber was filled with 20 liters of sunflower oil.

A typical gas composition measured in the gasification tests performed in the laboratories of the University of Perugia, is reported in table 2.

Table 2. Composition and heating value of producer gas

Gas concentration	Value
H ₂ (%v)	12.30
O ₂ (%v)	4.60
N ₂ (%v)	52.60
CH ₄ (%v)	0.98
CO (%v)	18.90
CO ₂ (%v)	9.53
C ₂ H ₆ (%v)	1.09
LHV [kJ/kg]	4,036

The heating value of the gas resulted to be higher with respect to the value assumed in the design phase, while tar concentration at the outlet of the cleaning system was about 5 g/Nm³. The values presented in table 2 agree with those of other studies [34]. In this first preliminary tests the producer gas was used to fuel the Lombardini LGA 340 ICE, working smoothly in idle condition. The trends of the temperatures of the pyrolysis zone, oxidation zone and gasification zone inside the reactor are shown in figure 4. The gasification temperature trend is clearly constant, because it is not influenced by the opening of the reactor hopper when a new charge of biomass is introduced. Pyrolysis temperature is obviously lower with respect to gasification temperature.

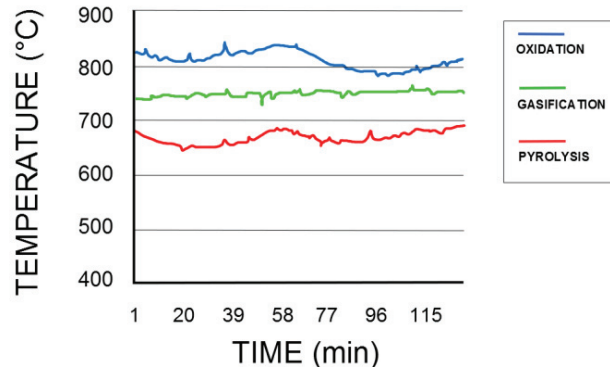

Fig. 4. Temperature trends inside the reactor

The used sunflower oil scrubber demonstrated a scrubbing efficiency, equal to 80 %, in agreement with previous works in collaboration with Tokyo Institute of Technology [12].

Figure 5 shows tar removal efficiency as a function of the amount of producer gas passed through the vegetable oil. With 20 liters of vegetable oil an efficiency of 67% removal was obtained 70 Nm³ of gas were cleaned; this value decreased to 53% when 112 m³ were treated from an initial value of 80%, hence an average oil consumption of 1-3 lt/h maybe considered. However the residual oil-tar mixture could be burnt successfully in a diesel engine providing additional 2-6 kWe of useful electric power.

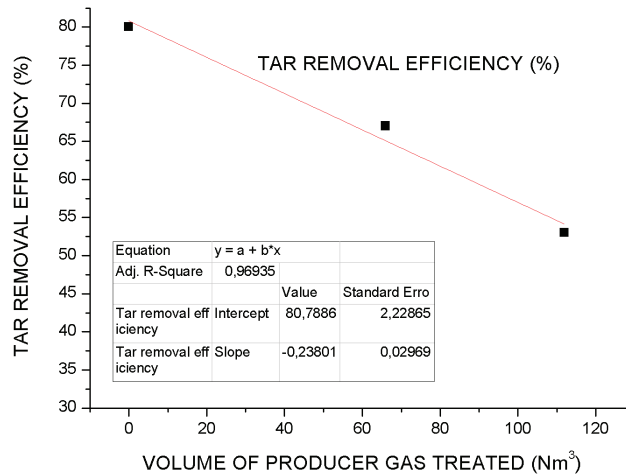

Fig. 5. Tar removal efficiency vs volume of producer gas treated

The mass balance during preliminary tests is shown in table 3.

Table 3. Gasification Mass balances I n Experimental test

	Experimental conditions (15% biomass moisture)
INPUT	
Biomass (kg/h)	5.00
Air (kg/h)	7.74
OUTPUT	
Solid residue (kg/h)	0.50
Tar and water (kg/h)	1.47
Producer gas	10.77

It could be seen from table 3 that design condition had forecasted a solid residue that is about 10% of the dry matter for biomass inserted in the reactor, while in experimental case this percentage was equal to 12%. Decreasing this value would provide a better efficiency.

Optimizing air flow also could improve efficiency: in experimental conditions an equivalence ratio of 0.4 was used, while the optimal equivalence ratio should be comprised in the 0.25-0.3 interval.

3.2. Internal combustion engine

The Internal Combustion Engine Lombardini LGA 340 worked continuously and smoothly in idle condition, when fuelled with producer gas. After the test the throttle valve was weighted, cleaned and remounted showing that with olive oil scrubbing tar deposit on the valve was lower, respect to water scrubbing (see figure 6).

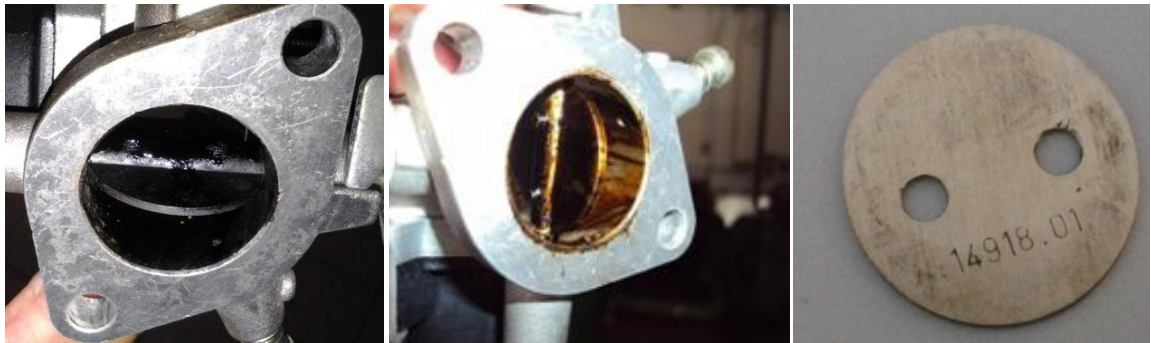

Fig. 6. (a) Throttle valve tar deposits with water scrubbing, (b) oil scrubbing; (c) cleaned throttle valve

A datasheet on the most important characteristics of the engine is reported in table 4.

Table 4. Lombardini LGA 340 Engine Technical Data

Technical data	Value
Cylinders (n)	1
Bore (mm)	82
Stroke (mm)	64
Displacement (cm ³)	338
Compression ratio	8.5:1
Power (with LPG)	6 KWe
Max torque (Nm/kgm)	23.7/2.42
Min. specific fuel consumption (g/kWh)	342
Fuel tank capacity (l)	6.0

3.3. SOFC Button Cell

Eventually syngas was fed to a button cell SOFC at the Fuel Cell Lab of the University of Perugia. Tests were carried out with an atmospheric pressure NiYSZ/YSZ/LSCF button cell (figure 7) supplying syngas at the anode (fuel electrode) and air at the cathode. Syngas to be sent to the anode chamber was drawn after the cleaning unit, which was discussed above.

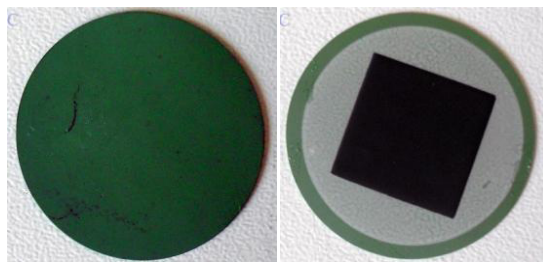

Figure 7 (left) SOFC anode, (right) SOFC cathode

Figure 8 shows cell performances during the operation with syngas. SOFC was operated at constant current load (0.5 A) during all the duration of trial.

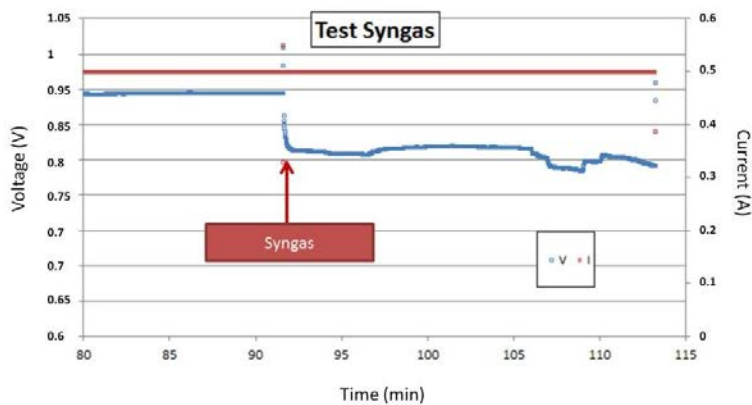

Figure 8: Constant load SOFC performance under syngas.

Before connecting the gasifier to the cell feeding line, the fuel used in the SOFC was 100% pure hydrogen. When hydrogen is replaced by syngas, a decrease in cell voltage is shown as predicted because carbon dioxide and nitrogen are diluting the active species (hydrogen, carbon monoxide and methane) in producer gas, causing a decrease in the maximum voltage achievable.

The trial lasted for two hours and during that period voltage was quite stable. Any small fluctuation is to be ascribed to the variation in syngas composition. To this end, a GC online analysis was performed on the syngas entering the cell. Figure 9 depicts how the concentration of the major species changed over time. The gas sampling frequency was 0.5 samples/minute. Gas composition is different from that shown on table 2 because they were taken during different tests.

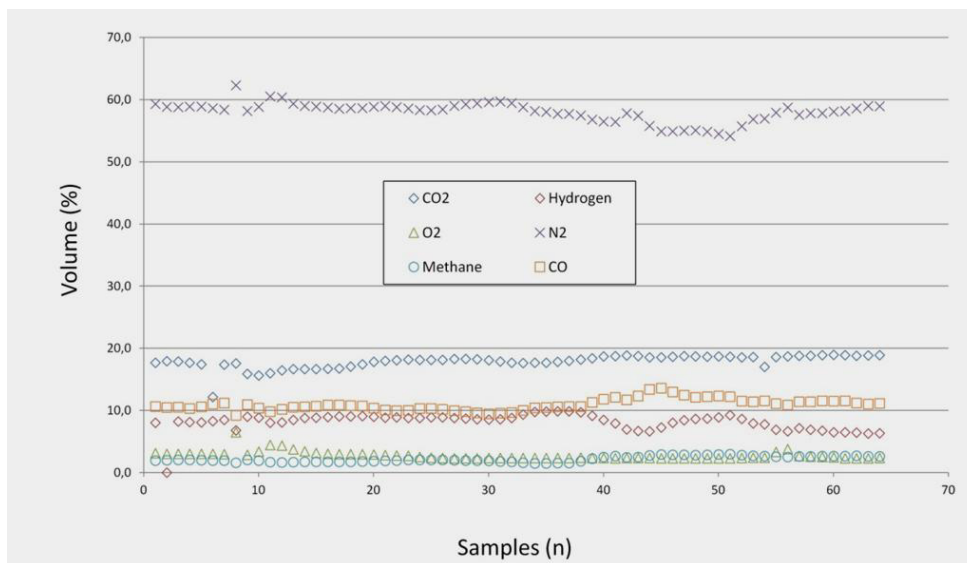

Figure 9 Fast online GC analysis on syngas supplied to the SOFC

This preliminary study demonstrates that the coupling of the two systems is feasible and further researches are ongoing.

4. Conclusions

This work analyses the production of energy from biomasses on micro-scale from different perspectives: from the obtainment of producer gas from a gasifier to the cleaning of it removing tar in a scrubber filled with vegetable oils, to the use of producer gas in engine and SOFC.

The experimental tests performed and presented in this paper have shown an interesting heating value of the gas, equal to 4 MJ/kg, that was used to run successfully an ICE and a SOFC button cell.

The results obtained from the experimental campaign were compared with the mass and energy balance assumed during the design phase. Further tests will concentrate the attention on the optimization of producer gas quality, controlling air volumetric flow in the reactor, based on oxygen measures and on the temperatures measured in the three zones of the reactor (pyrolysis, oxidation and gasification).

References

- [1] Asadullah M., Barriers of commercial power generation using biomass gasification gas: A review *Renewable and Sustainable Energy Reviews*, Volume 29, 2014, Pages 201-215
- [2] Arena U., 2012, Process and technological aspects of municipal solid waste gasification. A Review. *Waste Management*, Volume 32, Issue 4, April 2012, Pages 625-639
- [3] D'Alessandro B., D'Amico M., Desideri U., Fantozzi F., The IPRP (Integrated Pyrolysis Regenerated Plant) technology: From concept to demonstration, *Applied Energy*, ELSEVIER, Volume 101, January 2013, Pages 423-431, ISSN: 03062619 DOI: 10.1016/j.apenergy.2012.04.036
- [4] Fantozzi F. , D'Alessandro B., Desideri U., Integrated Pyrolysis Regenerated Plant (IPRP): An efficient and scalable concept for gas turbine based energy conversion from biomass and waste, *Journal of Engineering for Gas Turbines and Power* Volume 127, Issue 2, April 2005, Pages 348-357, ISSN: 07424795 DOI: 10.1115/1.1789513
- [5] Fantozzi, F., D'Alessandro, B. Desideri, U. (2007) An IPRP (Integrated Pyrolysis Regenerated Plant) microscale demonstrative unit in Central Italy, *Proceedings of the ASME Turbo Expo*, Volume 1, 2007, Pages 453-458, 2007 ASME Turbo Expo; Montreal, Que.; Canada, ISBN: 079184790X;978-079184790-9 DOI: 10.1115/GT2007-28000
- [6] Di Maria F., Fantozzi F., Life cycle assessment of waste to energy micro-pyrolysis system: Case study for an Italian town *International Journal of Energy Research*, ELSEVIER, Volume 28, Issue 5, April 2004, Pages 449-461, ISSN: 0363907X DOI: 10.1002/er.977
- [7] Fantozzi F., D'Alessandro B., Bidini G., IPRP (Integrated Pyrolysis Regenerated Plant): Gas turbine and externally heated rotary-kiln pyrolysis as a biomass and waste energy conversion system. Influence of thermodynamic parameters, *Proceedings of the Institution of Mechanical Engineers, Part A: Journal of Power and Energy*, Volume 217, Issue 5, 2003, Pages 519-527, ISSN: 09576509 DOI: 10.1243/095765003322407566
- [8] Reed T.B., Das A.– Handbook of biomass downdraft gasifier engine systems – U.S. Department of Energy: Solar Energy Research Institute (1988).
- [9] IEA Energy Technology Essentials, Biomass for Power Generation and CHP, ETE03, January 2007.
- [10] Guo F., Dong Y., Dong L., Guo C., Effect of design and operating parameters on the gasification process of biomass in a downdraft fixed bed: An experimental study, *International Journal of Hydrogen Energy*, Volume 39, Issue 11, 4, 2014, Pages 5625-563
- [11] Asadullah M., Biomass gasification gas cleaning for downstream applications: A comparative critical review, *Renewable and Sustainable Energy Reviews*, Volume 40, December 2014, Pages 118-132
- [12] Paethanom A., Bartocci P., D' Alessandro B., D' Amico M., Testarmata F., Moriconi N., Slopiecka K., Yoshikawa K., Fantozzi F., A low-cost pyrogas cleaning system for power generation: Scaling up from lab to pilot *Applied Energy*, ELSEVIER, Volume 111, 2013, Pages 1080-1088, ISSN: 03062619, DOI: 10.1016/j.apenergy.2013.06.044
- [13] Shivapuji A. M., Dasappa S., In-cylinder investigations and analysis of a SI gas engine fuelled with H₂ and CO rich syngas fuel: Sensitivity analysis of combustion descriptors for engine diagnostics and control, *International Journal of Hydrogen Energy* Volume 39, Issue 28, 23 September 2014, Pages 1578615802 doi:10.1016/j.ijhydene.2014.07.122
- [14] Hagos F. Y., Aziz A. R. A., Sulaiman S. A., Effect of Air-fuel Ratio on the Combustion Characteristics of Syngas (H₂:CO) in Direct-injection Spark-ignition Engine, *Energy Procedia*, Volume 61, 2014, Pages 2567-2571, doi:10.1016/j.egypro.2014.12.047
- [15] Chacartegui R., Torres M., Sanchez D., Jiménez F., Munoz A., Sánchez T., 2011, Analysis of main gaseous emissions of heavy duty gas turbines burning several syngas fuels, *Fuel Processing Technology*, ELSEVIER, Volume 92, Issue 2, 2011, Pages 213-221, doi:10.1016/j.fuproc.2010.03.01
- [16] Fantozzi F., Laranci P., Bianchi M., De Pascale A., Pinelli M., Cadorin M., CFD simulation of a microturbine annular combustion chamber fueled with methane and biomass pyrolysis syngas - Preliminary results", *Proceedings of the ASME Turbo Expo*, Volume 2, 2009, Pages 811-822 2009 ASME Turbo Expo; Orlando, FL; United States; ISBN: 978-079184883-8 DOI: 10.1115/GT2009-60030
- [17] Fantozzi F., Colantoni S., Bartocci P., Desideri U., Rotary kiln slow pyrolysis for syngas and char production from biomass and waste - Part I: Working envelope of the reactor *Journal of Engineering for Gas Turbines and Power* Volume 129, Issue 4, October 2007, Pages 901-907, DOI: 10.1115/1.2720521

- [18] Fantozzi, F., Colantoni, S., Bartocci, P., Desideri, U., Rotary kiln slow pyrolysis for syngas and char production from biomass and waste - Part II: Introducing product yields in the energy balance, *Journal of Engineering for Gas Turbines and Power* Volume 129, Issue 4, October 2007, Pages 908-913, ISSN: 07424795 DOI: 10.1115/1.2720539
- [19] Fantozzi F., Desideri U., Simulation of power plant transients with artificial neural networks: Application to an existing combined cycle, *Proceedings of the Institution of Mechanical Engineers, Part A: Journal of Power and Energy*, Volume 212, Issue 5, 1998, Pages 299-313, ISSN: 09576509
- [20] D'Alessandro B., Laranci P., Testarmata F., Fantozzi F., Experimental and CFD evaluation of the part load performance of a micro gas turbine fuelled with CH₄-N₂ mixtures, *Proceedings of the ASME Turbo Expo*, Volume 1, 2012, Pages 693-700, ASME Turbo Expo 2012: Turbine Technical Conference and Exposition, GT 2012; Copenhagen; Denmark; 11 June 2012 through 15 June 2012; ISBN: 978-079184467-0 DOI:10.1115/GT2012-69790
- [21] D'Alessandro B., Bartocci P., Fantozzi F., Gas turbines CHP for bioethanol and biodiesel production without waste streams, *Proceedings of the ASME Turbo Expo* Volume 1, 2011, Pages 691-700 ASME 2011 Turbo Expo: Turbine Technical Conference and Exposition, GT2011; Vancouver, BC; Canada; ISBN: 978-079185461-7, DOI: 10.1115/GT2011-46683
- [22] Fantozzi, F., Laranci, P., Bidini, G., CFD simulation of biomass pyrolysis syngas vs. natural gas in a microturbine annular combustor, *Proceedings of the ASME Turbo Expo* Volume 1, 2010, Pages 649-658 ASME Turbo Expo 2010: Power for Land, Sea, and Air, GT 2010; Glasgow; United Kingdom; ISBN: 978-079184396-3 DOI: 10.1115/GT2010-23473
- [23] Laranci P., Bursi, E., Fantozzi, F., Numerical analysis of a microturbine combustion chamber modified for biomass derived syngas, *Proceedings of the ASME Turbo Expo*, Volume 2, Issue PARTS A AND B, 2011, Pages 541-548 ASME 2011 Turbo Expo: Turbine Technical Conference and Exposition, GT2011; Vancouver, BC; Canada; ISBN: 978-079185462-4 DOI: 10.1115/GT2011-45551
- [24] Dey T., Singdeo D., Pophale A., Bose M., Ghosh P C., SOFC Power Generation System by Bio-gasification, *Energy Procedia*, Volume 54, 2014, Pages 748-755
- [25] Ahrenfeldt J., Thomsen T. P., Henriksen U., Clausen L. R., Biomass gasification cogeneration – A review of state of the art technology and near future perspectives, *Applied Thermal Engineering*, Volume 50, Issue 2, February 2013, Pages 1407-1417
- [26] Fryda L., Panopoulos K.D., Kakaras E., 2008, Integrated CHP with autothermal biomass gasification and SOFC–MGT Energy Conversion and Management, Volume 49, Issue 2, February 2008, Pages 281-290
- [27] Colantoni, S., Corradetti, A., Desideri, U., Fantozzi, F., 2007, Thermodynamic analysis and possible applications of the Integrated Pyrolysis Fuel Cell Plant (IPFCP), *Proceedings of the ASME Turbo Expo* Volume 1, 2007, Pages 427-436 2007 ASME Turbo Expo; Montreal, Que.; Canada; ISBN: 079184790X;978-079184790-9 DOI: 10.1115/GT2007-27713
- [28] Desideri U, Fantozzi F. 2013. Biomass combustion and chemical looping for carbon capture and storage. In: *Technologies for Converting Biomass to Useful Energy: Combustion, Gasification, Pyrolysis, Torrefaction and Fermentation*, E. Dahlquist editor, New York: CRC Press, p.129-167. ISBN 9780415620888
- [29] Basu P, *Biomass Gasification and Pyrolysis, Practical design and theory*, Oxford, Elsevier, 2010.
- [30] Coronado C R, Yoshioka J T, LSilveira J, Electricity, Hot water and cold water production from biomass. Energetic and economical analysis of the compact system of cogeneration run with woodgas from a small downdraft gasifier, *Renewable Energy* 36 (2011) 1861-1868.
- [31] Bacaicoa P G; Bilbao R; Arauzo J; Salvador L., “Scale-up of downdraft gasifiers – design, experimental aspects and results” *Bioresource Technology* 48 (1994) 229-235.
- [32] Basu P, *Combustion and Gasification in Fluidized Beds*, CRC Press, 2006.
- [33] CEN/TS 15439, “Biomass gasification – Tar and particles in product gases – Sampling and analysis”, 2006.
- [34] Hernández J.J., Barba J, Aranda G., Combustion characterization of producer gas from biomass gasification, *Global NEST Journal*, 2012, Vol 14, No 2, pp 125-132.