

This is the peer reviewed version of the following article:

Structural Organization of Dream Experience During Daytime Soremp Sleep of Patients with Narcolepsy Type 1 / Cipolli, Carlo; Pizza, Fabio; Bellucci, Claudia; Mazzetti, Michela; Tuozi, Giovanni; Vandi, Stefano; Plazzi, Giuseppe. - In: SLEEP. - ISSN 0161-8105. - 43:8(2020), pp. 1-10. [10.1093/sleep/zsaa012]

*Terms of use:*

The terms and conditions for the reuse of this version of the manuscript are specified in the publishing policy. For all terms of use and more information see the publisher's website.

29/06/2024 18:45

(Article begins on next page)

**STRUCTURAL ORGANIZATION OF DREAM EXPERIENCE DURING DAYTIME SOREMP  
SLEEP OF PATIENTS WITH NARCOLEPSY TYPE 1**

**Carlo Cipolli<sup>1</sup>, Fabio Pizza<sup>2,3</sup>, Claudia Bellucci<sup>1</sup>, Michela Mazzetti<sup>1</sup>, Giovanni Tuozi<sup>4</sup>,  
Stefano Vandi<sup>2,3</sup>, Giuseppe Plazzi<sup>2,3</sup>**

1 Department of Experimental, Diagnostic and Specialty Medicine,, University of Bologna, Bologna, Italy

2 Department of Biomedical and Neuromotor Sciences, University of Bologna, Bologna, Italy

3 IRCSS Istituto delle Scienze Neurologiche di Bologna, Bologna, Italy

4 Department of Psychology, University of Bologna, Bologna, Italy

**Correspondence to:** Giuseppe Plazzi, MD

Department of Biomedical and Neuromotor Sciences, University of Bologna, Bologna, Italy

Ospedale Bellaria, Padiglione G, Via Altura 3, 40139 Bologna, Italy

E-mail: giuseppe.plazzi@unibo.it

## ABSTRACT

### Study Objective

To assess the frequency of dream experience (DE) developed during naps at Multiple Sleep Latency Test (MSLT) by patients with narcolepsy type-1 (NT1) and establish, using story-grammar analysis, the structural organization of DEs developed during naps with sleep onset REM period (SOREMP) sleep compared with their DEs during early-and late-night REM sleep.

### Methods

Thirty drug-free cognitively intact adult NT1 patients were asked to report DE developed during each MSLT nap. Ten NT1 patients also spent voluntarily a supplementary night being awakened during the first-cycle and third-cycle REM sleep. Patients provided dream reports, white dreams and no dreams, whose frequencies were matched in naps with SOREMP vs non-REM (NREM) sleep. All dream reports were then analysed using story-grammar rules.

### Results

DE was recalled in detail (dream report) by NT1 patients after 75% of naps with SOREMP sleep and after 25% of naps with NREM sleep. Dream reports were provided by 8 out of 10 NT1 patients after both awakenings from night-time REM sleep. Story-grammar analysis of dream reports showed that SOREMP-DEs are organized as hierarchically ordered sequences of events (so-called dream-stories), which are longer and more complex in the first and fourth SOREMP-naps and are comparable with night-time REM-DEs.

### Conclusions

The similar structural organization of SOREMP-DEs with night-time REM-DEs indicates that their underlying cognitive processes are highly, albeit not uniformly, effective during daytime SOREMP sleep. Given the peculiar neurophysiology of SOREMP sleep, investigating SOREMP-DEs may cast further light on the relationships between the neurophysiological and psychological processes involved in REM-dreaming.

**Keywords:** narcolepsy type 1; MSLT; sleep onset REM period; dream recall; structural organization of dream experience.

### **Statement of Significance**

The long and complex story-like organization of dream experiences developed by NT1 patients during daytime naps with SOREMP sleep proved to be comparable to that of their dream experiences during early- and late-night-time REM sleep. This finding suggests that MSLT may be a parsimonious (i.e., within the clinical routine) and extended (from mid-morning to late afternoon) multiple-nap protocol to investigate the general process of REM dreaming. The peculiar neurophysiology of SOREMP sleep may provide important insights into some unexplored issues of REM-dreaming such as the across-stage (transition from NREM sleep stage 1 or 2 to SOREM sleep) and across-state continuity (alternation of SOREMP-wake-SOREMP during the same nap) of the cognitive and emotional processes involved in dream generation.

Accepted Manuscript

## INTRODUCTION

Studies on patients with sleep disorders have provided several insights into the influence of the altered organization of sleep on dreaming as well as into how neurophysiological and psychological processes interact in dream generation (for review [1]).

Narcolepsy with cataplexy (narcolepsy type 1, NT1), which is pathophysiologically linked to the loss of the hypothalamic neurons producing hypocretin [2], promises unique opportunities to further extend our knowledge on dream generation during rapid eye movement (REM) sleep. Indeed, the hallmarks of this brain disease are a number of dissociated REM-sleep events intruding into wakefulness (cataplexy, sleep related paralyzes and hallucinations), and diurnal hypersomnolence with an untimely fast transition (in less than 15 minutes) from wakefulness to REM sleep at daytime [3] and night-time sleep onset (sleep onset REM sleep period, SOREMP) [4]. Although the occurrence of two or more SOREMPs during the Multiple Sleep Latency Test (MSLT) is the most specific NT1 neurophysiological marker since more than 40 years [5,6], the mental experience (usually termed “dream experience”, DE) developed during these periods has been rarely investigated (for review [7]).

Given the considerable proportion of MSLT naps with SOREMP in NT1 patients (about two thirds [8,9]), collecting dream report after each nap may provide novel features of SOREMP-DE and the cognitive processes involved in its generation. However, to evaluate whether the indications drawn from MSLT can be extended to the general process of dreaming, all the main cognitive characteristics of DE of SOREMP naps of NT1 patients must be established, also in comparison with those of night-time REM sleep.

As yet, only a few cognitive features (such as vividness and bizarreness) of DE of around-noon SOREMP naps have been investigated and proved similar to those of DE of night-time REM sleep in NT1 patients [10,11]. Among the most important cognitive features of SOREMP-DE the structural organization is still missing. Indeed, as shown by studies on healthy subjects, DE is not only usually perceptually vivid and bizarre in contents, but also organized into lengthy and quite coherent narratives of fairly plausible events. This story-like organization is intrinsic to DE, as its contents rarely reproduce recent and remote events (i.e., episodic memories [12]), but result from the combination of several episodic and semantic memories (i.e., items of general knowledge [13]) in a much more novel manner than a simple collage [14]. Moreover, the features of story-like organization remain stable in the comparison of reports collected after night awakening with those of next morning [15], similarly to reports of short films at immediate and delayed recall [16]. Interestingly, the structural organization of DE of REM sleep is uniformly high over the night in NT1 patients, differently from healthy subjects, in whom it increases in late night [17,18].

We here report the findings of two studies where, beside evaluating the frequency of dream recall (DRF), we assessed the DEs reported i) after each nap with or without SOREMP sleep (hereinafter SOREMP and non-REM, NREM - naps) on a consecutive series of cognitively intact adults undergoing MSLT trials and with final diagnosis of NT1, and ii) on a subsample of these patients who accepted to spend a further night where they were awakened from night-time REM sleep of the first and third cycles. All reported DEs were analyzed using the formal rules of a story grammar, which proved capable to distinguish the influence of ultradian (NREM vs REM sleep) [19] and circadian factors (early- vs late- night REM sleep) [20] on the structural organization of DEs of healthy subjects. In this manner we attempted to ascertain whether the structural organization of DE a) is more complex in SOREMP naps than NREM naps, b) is similar in SOREMP naps compared to night-time REM sleep, and c) is influenced by circadian factors (i.e. varies over MSLT naps).

## METHODS

**Participants** A consecutive series of cognitively intact adults with final diagnosis of NT1 with normal neurophysiological findings were recruited among the outpatients consecutively evaluated for suspected narcolepsy at the Narcolepsy Center of the University of Bologna from January 2017 to December 2018.

All patients were drug-free (i.e. drug-naïve or after 3-week withdrawal) at diagnostic work-up that included the following procedures [21]: (i) clinical evaluation; (ii) subjective sleepiness assessment (Epworth Sleepiness Scale, ESS) [22]; (iii) 48-h continuous polysomnographic (PSG) recording (24-h for adaptation and 24-h for diagnostic purposes) followed by; (iv) five MSLT trials [23], taking place at 9 a.m., 11 a.m., 1 p.m., 3 p.m., and 5 p.m.; (v) in-laboratory test to elicit cataplexy [21,24]; (vi) blood test and, whenever possible, lumbar puncture to search the human leukocyte antigen (HLA) DQB1\*0602 [25] and cerebrospinal hypocretin-1 levels respectively. According to the current international criteria [2], a final diagnosis of NT1, narcolepsy without cataplexy (narcolepsy type 2: NT2), idiopathic hypersomnia (IH), or subjective sleepiness was provided.

To be eligible for the study patients had also to fulfill the following criteria: (i) age between 18 and 50 years; (ii) 8 or more years of education; (iii) no history of neurological, psychiatric, or sleep comorbidity; (iv) ability to recall at least one dream per week (retrospectively evaluated over the previous two months); (v) lack of global and memory-specific cognitive deficits, i.e. without scores below the cut-off points of mild deficit on the Wechsler Adult Intelligence Scale - Revised (WAIS-R [26] for global and specific cognitive functions, and the Wechsler Memory Scale (WMS [27]) for short- and long-term memory.

The 41 eligible NT1 patients were requested to participate in a study consisting in reporting the DE developed during each MSLT nap: the 34 patients who accepted gave written informed consent according to the study protocol approved by the local Ethics Committee.

## Procedure

**First Part.** Four out of 34 patients showing a comorbid sleep disorder on 48-h continuous PSG were excluded.

Before the first MSLT trial, participants were instructed that after each MSLT trial they would be asked by an investigator (C.B., blind to patient's clinical diagnosis) to provide a report of the mental experience developed during sleep (using the classical Foulkes' [28] instruction, "Would you tell me whatever was going through your mind before awakening?"). According to Cohen's [29] criteria, patients could be a) able to recall contents of the previous mental experience (dream, i.e. contentful report), b) unable to recall contents of the mental experience that had been felt to occur (white dream, i.e. contentless report), c) unable to recall any experience before awakening (no dream, i.e. dreamless report). In the first case, after the free (i.e., spontaneous) recall, participants would be asked again: "Could you remember one or more further events of the same mental experience you have just reported?". After this possible (prompted) recall patients had to specify if the further recalled events were experienced before or after those described in the spontaneous recall.

**Second Part.** At the end of the diagnostic work-up, the 13 NT1 patients living not farther than two hours of car travel from Bologna were requested to spend a further night in laboratory for scientific purposes on the following week-end. The voluntary participation of patients allowed us to separate the clinical routine from the experimental one.

Ten out of 13 eligible patients who accepted underwent the same procedure of PSG recording and were awakened after 8 minutes of REM sleep in the two halves of the night, namely in the first (excluding a possible SOREMP) and third sleep cycle [18].

### Sleep scoring and analysis of dream reports

All PSG recordings were scored according to the international criteria [30] by a board-certified PSG technician (S.V.).

The following sleep parameters were calculated for MSLT naps and the night-time sleep in the second 24 h continuous PSG recording: sleep (SL) and REM sleep (REML) latency, total sleep time (TST), wakefulness after sleep onset (WASO), sleep efficiency (SE), time in bed (TIB), the overall duration of each sleep stage (Non REM sleep stage 1, 2, and 3; N1, N2, N3; REM). For MSLT naps also the number and duration of segments of SOREMP sleep (i.e. transitions from SOREMP sleep to wake bouts longer than 10 seconds [31]) were calculated.

Only sleep recordings and reports of patients finally diagnosed as NT1 (n=30) were considered for the first part, and those of 8 NT1 patients for the second part of

the study, as 2 patients did not provide dream reports after either night-time REM sleep awakenings.

### **Dream Recall Frequency**

We calculated separately the proportion of dream reports and that of dream reports plus white dreams out of the number of naps. The former measure informs us about the perceptual and emotional characteristics of DEs and their structural organization, the latter measure seems capable to estimate more accurately the “real” occurrence of DEs during SOREMP and NREM sleep [32]. Indeed, the main neural EEG correlates of the sleep periods preceding dream reports and white dreams are very similar, unlike those preceding no dream [33]. By comparing the two measures we attempted to account for the previous discrepant estimates of dream recall obtained in MSLT compared to experimental studies on NT1 patients.

### **Report analysis**

The verbatim transcripts of the whole (i.e. spontaneous plus possibly prompted) reports were pruned from clauses not related to or repetitive of dream contents and comments on possible dissociative phenomena occurring during sleep. Then reports were scored independently by two expert psycholinguists (E.R. and G.A.), unaware of the study aims, who identified the structural organization of DE using the rules of Mandler and Johnson’s [34] story grammar (for the definition of rules and description of the procedure of analysis, see [15] and Supplementary Materials).

The outcome of story-grammar analysis is a tree structure going from the most general constituent (*Story*, namely one or more events linked by the same *Setting* and *Characters*) to the terminal nodes (*Statements*, describing either a *State* or *Event*). In its simplest form, a (dream-)story consists of a *Setting* (time and place of the event to be narrated) and an *Event structure*, with one or more *Episodes*, each having several intermediate constituents (Figure 1).

Inter-scorer agreement was higher than 98% in parsing statements and classifying statements into intermediate constituents, 96% in classifying constituents into episodes, and was complete (100%) in classifying episodes into dream-stories. The few disagreements were solved through discussion between the two psycholinguists. The values of interscorer agreement were high because of the story-grammar rules were explicit and not ambiguous.

The following indicators were calculated for both parts of the study: a) the report length (i.e., number of statements per report), b) the number of dream-



stories (i.e., sequences of connected events with the same characters and setting) per report, c) the length of dream-stories (measured as number of statements), and d) the indicators of structural organization dream-stories, namely:

d1) *Context organization* (i.e., number of statements per dream-story describing Setting), which is indicative of recall accuracy;

d2) *Sequential* (i.e., temporal) *Organization* (i.e., number of statements per story realizing the actions of Event structure), which is indicative of coherence of dream contents; and

d3) *Hierarchical organization* (i.e., number of episodes per story) which is indicative of the complexity of the dream plot.

### Data analysis

SPSS version 21 was used for the analysis of parametric (MANOVA, ANOVA, Student's t, Pearson's correlation) and non-parametric data ( $\chi^2$ , sign test and Cochran's Q test). All statistical tests were two-tailed and alpha level was fixed at 0.05.

## RESULTS

### 1. Demographic, psychometric and PSG indicators of NT1 and sc-EDS participants

Male (n=14) and female (n=16) NT1 patients differed significantly for age (respectively,  $39.29 \pm 8.09$  vs  $30.69 \pm 10.13$  yrs;  $F_{1,28} = 6.477$ ,  $p = 0.017$ ), but neither for years of education ( $11.07 \pm 3.12$  vs  $12.88 \pm 2.42$ ;  $F_{1,28} = 3.168$ ,  $p = 0.086$ ) or values of psychometric indicators (Table 1a).

Among the values of sleep parameters of full-night PSG recordings before MSLT (Table 1b) and of MSLT naps (Table 1c) only night-time WASO (higher in males) and daytime N2 (higher in females) showed significant differences.

Therefore, given the almost complete lack of significant differences between male and female patients, their sleep and dream data were pooled in subsequent analyses.

## 2. MSLT findings

### 2.1. Naps with and without SOREMP sleep.

The proportion of naps (i.e., at least 30 sec of documented sleep) with SOREMP sleep (83.22%) was higher than that of naps only with NREM sleep (16.78%) in all MSLT trials (sign test ranging from  $p=.001$  to  $.05$ ), while it did not vary significantly (ranging from 96.3% to 76.7%) over the time of day (Cochran's Q Test= 3.294,  $df= 4$ ,  $p= .510$ ) in the 29 NT1 patients who slept in all MSLT trials. On the contrary, the high proportion of provoked awakenings at the end of the trials did not differ in SOREMP naps (90.32%) compared to NREM naps (88.00 %) ( $\chi^2= 0.123$ , n.s.).

An ANOVA on all NT1 patients ( $F_{2,58} =54.204$ ;  $p<.001$ ) showed that the transition to SOREMP sleep was significantly more frequent from N1 (81.45%) than N2 (15.32%) or wakefulness (3.22%) (Table 2a). Separate ANOVAs on the 16 NT1 patients with SOREMP sleep in all naps showed a) a more frequent transition to SOREMP sleep from N1 and N2 ( $F_{2,30}= 43.187$ ;  $p<.000$ ), b) a trend toward a varying duration of SOREMP sleep across naps ( $F_{4,60} =2.511$ ;  $p=.051$ ; but no pairwise comparison reached statistical significance), and c) no significant variation across naps ( $F_{4,60}=0.523$ ;  $p=.719$ ) in the number of segments of SOREMP sleep per nap (ranging from 2.37 to 3.00) (Table 2b).

### 2.2 Frequencies of dream recall after naps with and without SOREMP sleep.

The proportion of dream reports was significantly higher in SOREMP naps than NREM naps (75% vs 24%:  $\chi^2= 24.267$ ,  $p <.001$ ) (Table 3).

The across-naps distribution of dream reports was higher in the first SOREMP naps (92.86%) compared with third naps (61.54%: sign test,  $p= .030$ ) and marginally (i.e., by trend), fourth naps (65.22%: sig test,  $p=.070$ ), whereas it was not calculated for NREM naps because of their small number ( $n= 6$ ).

Conversely, the proportions of white dreams and no dream were significantly lower in SOREMP naps than NREM naps (respectively, 15.32% vs 40 %:  $\chi^2= 8.066$ ,  $p <.01$ ; 9.68% vs 36%:  $\chi^2= 11.929$ ,  $p <.001$ ).

### 2.3. Report length and structural organization of dream-stories in DEs of MSLT naps.

Given the lack of significant differences between the length of reports ( $19.90 \pm 11.29$  vs  $18.97 \pm 10.66$ :  $F_{1,28} = 0.053$ ,  $P= .820$ ) and of dream-stories ( $12.57 \pm 6.16$  vs  $11.61 \pm 5.03$ :  $F_{1,28} =0.211$ ,  $P=.650$ ) in male and female patients, the factor Gender was not considered in subsequent analyses.

Patients evaluated that dream-stories reported after SOREMP naps had been developed during sleep nearly always before those of spontaneous reports (17 out of 19,  $p < .001$ ).

One-way ANOVAs carried out for any trial on reports with two or more dream-stories showed that the length (in statements) of dream-stories did not differ according to whether they were reported at both spontaneous and prompted or only at spontaneous recall: first nap, 6 vs 9 patients;  $11.36 \pm 6.07$  vs  $9.46 \pm 5.64$ ,  $F_{1,13} = 0.384$ ;  $p = .546$ ; second nap, 5 vs 4 patients:  $11.33 \pm 5.43$  vs  $12.32 \pm 6.65$ ,  $F_{1,7} = 0.060$ ;  $p = .813$ ; third nap, 2 vs 6 patients:  $13.50 \pm 2.83$  vs  $10.66 \pm 7.53$ ,  $F_{1,6} = 0.248$ ;  $p = .636$ ; fourth nap, 3 vs 4 patients:  $17.17 \pm 2.52$  vs  $14.66 \pm 3.98$ ,  $F_{1,5} = 0.892$ ;  $p = .388$ ; and fifth nap, 3 vs 4 patients:  $10.83 \pm 10.05$  vs  $10.75 \pm 5.28$ ,  $F_{1,5} = 0.001$ ;  $p = .989$ ).

Then separate analyses were carried out on the indicators of structural organization of DEs reported by 25 patients after two or more SOREMP naps and 5 patients after both SOREMP and NREM naps (Table 4).

One-way ANOVAs on SOREMP reports of 25 patients showed significantly higher values in first-nap reports compared with the mean values of the following ones for a) the length (i.e., number of statements) of reports ( $22.20 \pm 12.98$  vs  $17.68 \pm 11.03$ :  $F_{1,24} = 4.401$ ;  $p = .047$ ) and dream-stories ( $13.65 \pm 8.48$  vs  $10.42 \pm 4.69$ .  $F_{1,24} = 4.423$ ;  $p = .046$ ), but not the number of dream-stories per report ( $1.80 \pm 0.82$  vs  $1.52 \pm 0.68$ :  $F_{1,24} = 1.806$ ;  $p = .192$ ), and b) the sequential ( $11.08 \pm 7.44$  vs  $8.06 \pm 3.93$  statements in Event Structure:  $F_{1,24} = 5.175$ ;  $p = .032$ ) and hierarchical ( $2.69 \pm 1.89$  vs  $1.88 \pm 0.82$  episodes per dream-story:  $F_{1,24} = 6.086$ ;  $p = .021$ ), but not contextual organization of dream-stories ( $2.57 \pm 1.48$  vs  $2.29 \pm 1.08$  statements in Setting:  $F_{1,24} = 1.028$ ;  $p = .321$ ).

Additionally, the values of fourth-nap reports were significantly higher than those of fifth-nap reports (calculated on 10 patients) for hierarchical organization ( $3.05 \pm 1.62$  vs  $1.83 \pm 0.61$  episodes per dream-story:  $F_{1,9} = 5.731$ ;  $p = .040$ ) and marginally for sequential organization ( $12.85 \pm 7.18$  vs  $6.77 \pm 4.62$  statements in Event Structure:  $F_{1,9} = 4.194$ ;  $p = .071$ ).

Finally, the number of episodes per report was significantly correlated with SOREMP fragmentation (i.e., number of SOREMP segments per nap) in the fifth -nap reports (Pearson's  $\rho = .538$ ,  $p = .025$ ) and marginally in the first- ( $\rho = .357$ ,  $p = .073$ ) and third- nap reports ( $\rho = .493$ ,  $p = .052$ ), while the length of reports and dream-stories were not significantly correlated with SOREMP duration in naps of any trial ( $\rho$  ranging from  $-.274$  to  $.257$ ),.

One-way ANOVAs on reports provided by 5 NT1 patients after SOREMP and NREM naps showed that reports (respectively,  $28.33 \pm 14.19$  vs  $8.20 \pm 3.63$  statements;  $F_{1,4} = 10.650$ ;  $p = .031$ ) and dream-stories ( $17.16 \pm 5.27$  vs  $7.10 \pm 3.40$  statements;  $F_{1,4} = 18.112$ ;  $p = .013$ ) were longer after SOREMP naps, while the number of dream-stories was not significantly different ( $1.77 \pm 0.97$  vs  $1.20 \pm 0.45$ ;  $F_{1,4} = 4.516$ ;  $p = .101$ ). Moreover, the values of sequential (significantly:  $13.77 \pm 4.00$  vs  $4.70 \pm 2.49$  statements;  $F_{1,4} = 20.254$ ;  $p = .011$ ) and hierarchical organization (marginally:  $3.10 \pm 1.29$  vs  $1.60 \pm 0.55$  episodes per dream-story;  $F_{1,4} = 5.619$ ;  $p = .077$ ) were higher in dream-stories of SOREMP-nap reports than in those of NREM-nap reports, while the values of contextual organization did not differ significantly ( $3.39 \pm 1.55$  vs  $2.40 \pm 1.52$ ;  $F_{1,4} = 2.264$ ;  $p = .207$ ).

### 3. Night-time REM sleep findings

The 10 patients who spent a further night in sleep laboratory and were awakened two times after 8 min of REM sleep in the first (excluding possible SOREM episodes: 3 cases) and third cycle of night-time sleep showed 90% of dream reports and 10% of no dream after awakenings. The 2 patients with no dream after either awakening were not considered for statistical analysis. The mean values of report length, number and length of dream-stories and indicators of structural organization of dream-stories did not differ in SOREMP naps of the 8 NT1 patients providing dreamreports after both night-time REM awakenings compared to SOREMP naps of the other 21 NT1 patients providing dream reports (Table 5). In these 8 patients the mean values of the above indicators of DEs developed in SOREMP naps and those of DEs developed during early- and late-night REM sleep did not show any significant difference.

## DISCUSSION

This study showed that the structural organization of dream experiences (DEs) developed by cognitively intact NT1 patients during MSLT naps with SOREMP sleep is similar to that of DEs during night-time REM sleep. SOREM-DEs are ordered and lengthy sequences of story-like events linked by related characters and settings, with some circadian variations in length and complexity, which are not present in night-time DEs. These findings appear reliable, being completely consistent with PSG [8,9] and recall data [35,36] of previous MSLT studies, and might provide a plausible explanation for the low frequency of DEs reported after NREM naps.

**Dream recall frequency after MSLT** The proportion of dream reports after SOREMP naps (75%) was higher than that after NREM naps (24%) and replicated those obtained in previous MSLT studies (78.26% vs 35.41 [35], 73.82% vs 29.80% [36]). Conversely, the proportions of both white dreams

and no dream recall were lower after SOREMP naps (respectively, 15.32% and 9.68%) than after NREM naps (respectively, 40% and 36%).

Under the assumption that the sum of dream reports and white dreams is more reliably indicative of the “real” occurrence of DE during REM and NREM sleep in NT1 patients as it is in healthy subjects (in whom it has been shown that dream and white reports are associated with similar neurophysiological correlates [33]), the overall frequency of DE may be estimated as 90.32 % during SOREMP naps and 64% during NREM naps. These estimates of DE frequency, which are also consistent with those obtained from healthy subjects over multiple naps (for review, see 37), have two plausible implications.

First, the inferences drawn from the present findings on the structural organization of DE may be extended to the population of cognitively intact NT1 patients for daytime SOREMP sleep (93 out of 112 naps with DE, i.e. 83.05 %), but not for NREM sleep (only 6 out of 16 naps with DE, i.e. 37.5%: see Table 3). Second, the high frequency of white dreams during NREM-sleep naps appears indicative of a failure in dream recall rather than in dream generation. It seems plausible that NT1 patients, who usually report a wealth of vivid and bizarre DE contents (which are easier to retrieve [38]) after daytime SOREMP and night-time REM sleep [10], may provide a report of NREM-DE only when its contents are easily accessible in memory. The hypothesized attitude of not recalling NREM-DE could be reversed by means of a better dream report training, namely by asking patients to describe specific dream features at the end of the two nights preceding MSLT trials. This kind of training was successfully applied in the unique experimental study on SOREMP- and NREM-DEs of NT1 patients, which were collected after one or two naps per day around noon [39].

### **Story-like organization of dream experience of SOREMP naps and night-time REM sleep.**

The comparison of the indicators of structural organization for daytime SOREMP-DEs with those of DEs of early- and late-night REM sleep in the subsample of patients (who did not differ in all indicators of SOREM-DEs relative to other patients) showed that the number, length and complexity of dream-stories were similar (none of the six indicators considered differed significantly, see Table 5). Also the values of these indicators largely replicated those of previous studies [17,18], in which patients were awakened after equal periods of REM sleep in the same cycles (8 min), a duration that is comparable with the length of SOREMP-naps in the present study (about 9 min: see Table 2). Therefore, our findings corroborate the hypothesis that DEs developed during SOREMP naps are organized as ordered and lengthy sequences of story-like events rather than short events or series of isolated images (like those developed during N1 and N2 at sleep onset in healthy subjects [28,40]). Given the cognitive integrity of our NT1 patients and the peculiar neurophysiology of REM sleep of NT1 patients, the similar structural organization of SOREMP-DEs to that of night-time REM-DEs (in turn comparable to late-night REM-DEs in healthy subjects [17,18]) in principle allows investigating some issues of REM dreaming

which have not been approached in studies on healthy subjects (for some examples, see the Conclusions section).

### **Circadian variations in the story-like organization of SOREMP-DE.**

No indicator of structural organization in dream-stories differed significantly according to whether they were reported at spontaneous or prompted recall after SOREMP naps, consistent with findings of a previous study on night-time REM sleep of NT1 patients [18]. Since the order of reporting is usually inverse compared to that of generation [41], the similar length and complexity of dream-stories developed during the same SOREMP nap indicate that the underlying cognitive processes are of similar effectiveness.

The effectiveness of these processes, however, is modulated also by the time of day, as shown by variations in the length and structural organization of dream-stories across MSLT naps, unlike night-time REM sleep [18]. Indeed, the structural organization of SOREMP-DEs of the 16 NT1 patients with 5 SOREMP naps was not uniform: dream-stories were longer and more complex (i.e., with more episodes) in first-nap reports than in subsequent ones, and in fourth-nap reports than in fifth-nap ones. The former finding indicates that the late-night trend towards an increasing length and complexity of REM-DEs [40,42,43] extends into the mid-morning in NT1 patients as well as in healthy subjects [44]. The latter suggests the existence of multiple circadian trends in the functioning of specific cognitive processes involved in dreaming, given that the sleep pressure (which increases the dreamlike features of DE [45]) was maintained homogenous by the uniform 2-hours interval between MSLT trials.

Variations in the structural organization of SOREMP-DEs may be interpreted suitably within the theoretical frame of Foulkes' [46,47] cognitive model of dreaming, which postulates that DE results from the functioning of cognitive processes on three distinct levels. The high-level processes are responsible for the complexity of dream-stories (by planning the plot of the ongoing DE), the mid-level ones for the length of dream-stories (by inserting contents coherent with the plot), and the low-level processes for the recruitment of memory sources to be converted into contents. Several items of experimental evidence have confirmed that specific processes hypothesized to be located at different levels (such as working memory, language and access to episodic and semantic information) varies along with sleep stage, being more effective during REM than N2 sleep [48-50]. Moreover, the mechanisms of the multilevel cognitive model appear fully compatible [51] with those of recently developed neurobiological models of dreaming, which combine results from PSG dream studies and imaging studies of the brain during sleep [52,53].

The similar complexity (i.e., number of episodes) of dream-stories of SOREMP naps compared with those of night-time REM sleep in a subsample of representative NT1 patients replicates results from previous studies on night-time REM-sleep

[17,18], which in turn showed that the uniformly high complexity of overnight REM-DEs in NT1 patients is comparable to that of late-night REM-DEs in healthy subjects [40,,42,43]. The consistency of the results obtained in all studies on REM-dreams of NT1 patients suggests that the functioning of the high-level processes is similarly effective in daytime and night-time REM sleep.

Also the positive relationship between the fragmentation of SOREMP sleep (i.e., number of segments spaced by at least 10 sec of wakefulness) and the number of episodes per dream-story (but not of dream-stories) appears coherent with the above inference.. Indeed, this relationship indicates that the interruption of SOREMP sleep does not entail necessarily the conclusion of the ongoing dream-story, but its plot may be developed in further episodes after the resumption of SOREMP sleep (and, thus, across states: SOREMP-wake-SOREMP). In theoretical terms, the re-instantiation of the suspended plot of a dream-story, if confirmed in experimental studies in which NT1 patients are interviewed after a short interval from an across-state change (i.e., SOREMP-wake-SOREMP), could corroborate definitely the notion that the high-level processes can proactively guide and sustain the selection of the memory sources to be converted into contents (i.e., the low-level processes).

Complementarily, the length of the Event Structure of dream-stories of SOREMP naps proved to be comparable with that of night-time REM-DEs of NT1 patients in the present and previous studies. The consistency of these findings is indicative of a similar effectiveness also of the mid-level processes during daytime SOREMP and night-time REM sleep. The following pieces of experimental evidence further support this inference. First, new complex episodic relationships are better recalled after daytime SOREMP than NREM sleep in NT1 patients [54]. Second, weakly-related semantic relationships are activated after awakening from night-time REM sleep (in the period of REM-sleep inertia) more easily in NT1 patients compared with healthy subjects [55]. Notably, in healthy subjects the access to weakly-related information in a semantic priming task [56] is easier after awakening from late-night REM sleep (which is accompanied by longer and more complex dream-stories) than from early-night REM sleep. Third, NT1 patients have better performance for both convergent and divergent creative tasks while awake than do healthy subjects [57], in keeping with the hypothesis that the cognitive flexibility facilitates the conversion of memories into contents coherent with the dream plot.

To establish which level-specific processes are responsible for the circadian variations in length and complexity of SOREMP-DEs their functioning should be assessed during SOREMP sleep at the same time as MSLT trials. In particular, the following capacities should be measured: a) working memory (e.g., by delivering external stimuli [48,58]); b) activation of associative relationships (e.g., by performing a semantic priming task in the period of SOREMP-sleep inertia [56]); and c) access to episodic and semantic memories (e.g., by identifying associative relationships between dream contents and memory sources [50]).

## Conclusions

The findings of this study corroborate the hypothesis that the structural organization of DEs during SOREMP naps of cognitively intact NT1 patients is comparable to that of DEs during night-time-REM sleep, and has some circadian variations that are in part consistent with those observed on healthy subjects. These pieces of evidence, in complementing those available on the similarity of the perceptual [10] and emotional features [11] of SOREMP-DEs of NT1 patients with those of their early and late-night REM-DEs, suggest that the MSLT may be a parsimonious (i.e., within the clinical routine) and extended (from mid-morning to late afternoon) multiple-nap protocol to investigate the process of REM-dreaming [59].

The peculiar neurophysiology of SOREMP sleep may provide pertinent insights not only into the dissociative waking/REM-sleep phenomena peculiar of NT1 patients (such as lucid dreaming [60] and REM sleep behaviour disorder [61]), but also into some important issues of dream generation yet unresolved in studies on healthy subjects [62]. For example, the across-stage and across-state continuity in the functioning of specific cognitive processes underlying dream generation may be investigated by comparing the content and structural characteristics of the DEs developed during SOREMP sleep a) preceded by N1 or (less often) N2 sleep, and b) uninterrupted or with alternation of SOREMP-wake-SOREMP sleep.

Moreover, using some EEG and video-PSG indicators of dissociative wakefulness/REM-sleep phenomena (for example, the increased prefrontal gamma activity during SOREMP-sleep with dream awareness [60] and the dream enacted contents during episodes of REM sleep behaviour disorder (RBD). RBD [61]) may allow an objective temporal localization of the occurrence of specific dream contents. This means that, in the case of co-occurrence of dissociative wakefulness/REM-sleep phenomena during a SOREMP nap the temporal succession of DE contents could be established more reliably and accurately in NT1 patients than in healthy subjects. Additionally, the availability of a formal description of the structural organization of DE could allow to establish the role played (for example, that of one or more attempts to reach a goal: see Figure 1) by the contents of RBD episodes in the time course of REM-dreaming,



## **ACKNOWLEDGMENTS**

The authors are indebted to M.Iloti, G.Neccia and A.Maltoni for technical assistance in sleep recordings, to L. Vignatelli for visual sleep scoring, to G.C. Aston and E. Rigotti for the linguistic analysis of dream reports, to C. Baroncini for the linguistic assistance in the preparation of the manuscript, and two anonymous reviewers for their thorough and helpful comments and suggestions.

## **NON FINANCIAL DISCLOSURE**

The authors declare no potential conflicts of interest.

## **FINANCIAL DISCLOSURE**

This work was supported in part by funds of the University of Bologna for fundamental research to M. Mazzetti and G. Plazzi in 2016-8. G.Plazzi participated in advisory boards for UCB Pharma, JAZZ Pharmaceuticals, Bioprojet, and Idorsia outside the submitted work.

Accepted Manuscript

## REFERENCES

1. Schredl M. Dreams in patients with sleep disorders. *Sleep Med Rev*. 2009; 13(3):215-221.
2. American Academy of Sleep Medicine. *International classification of sleep disorders* (Third Edition) Darien, IL: American Academy of Sleep Medicine; 2014.
3. Vogel G. Studies in psychophysiology of dreams. III. The dream of narcolepsy. *Arch Gen Psychiatry* 1960; 3 (4): 421-428.
4. Rechtschaffen A, Wolpert EA, Dement WC, Mitchell SA, Fisher CI. Nocturnal sleep of narcoleptics. *Electroencephalogr Clin Neurophysiol.*, 1963; 15 (4): 599–609.
5. Richardson GS, Carskadon MA, Flagg W, Van den Hoed J, Dement WC, Mitler MM.. Excessive daytime sleepiness in man: multiple sleep latency measurement in narcoleptic and control subjects. *Electroencephalogr Clin Neurophysiol.* 1978;45 (5): 621-627.
6. Carskadon MA, Dement WC, Mitler MM, Roth T, Westbrook PR, Keenan S. Guidelines for the multiple sleep latency test (MSLT): a standard measure of sleepiness. *Sleep* 1986;9 (4):519-524.
7. Wamsley E. Dreaming in narcolepsy. In: M. Goswami, SR Pandi-Perumal, MJ Thorpy (eds). *Narcolepsy*. Springer, Switzerland, 2016: 257-264.
8. Drakatos P, Kosky CA, Higgins SE, Muza RT, Williams AJ, Leschziner GD. First rapid eye movement sleep periods and sleep-onset rapid eye movement periods in sleep-stage sequencing of hypersomnias. *Sleep Med* 2013a;14 (9): 897–901.
9. Drakatos P, Suri A, Higgins SE, *et al*. Sleep stage sequence analysis of sleep onset REM periods in the hypersomnias. *J Neurol Neurosurg Psychiatry* 2013b;84(2):223–227.
10. Fosse R. REM mentation in narcoleptics and normals: an empirical test of two neurocognitive theories. *Conscious Cogn.* 2000; 9(4):488-509.
11. Fosse R, Stickgold R, Hobson JA. Emotional experience during rapid-eye-movement sleep in narcolepsy. *Sleep* 2002; 25(7): 724-732.

12. Fosse MJ, Fosse R, Hobson JA, Stickgold RJ. Dreaming and episodic memory: a functional dissociation? *J Cogn Neurosci*. 2003; 15(1):1-9.
13. Tulving E. Elements of episodic memory. Oxford: Clarendon Press, 1983.
14. Pace-Schott E. Dreaming as a story-telling instinct. *Front Psychol*. 2013; Apr 2, 4: 159.
15. Cipolli C, Poli D. Story structure in verbal reports of mental sleep experience after awakening in REM sleep. *Sleep*, 1992; 15 (2), 133-142.
16. Montangero J, Ivanyi CT, de Saint-Hilaire Z. Completeness and accuracy of morning reports after a recall cue: comparison of dream and film reports. *Conscious Cogn.*, 2003; 12(1):49-62.
17. Cipolli C, Bellucci C, Mattarozzi K, Mazzetti M, Tuozi G, Plazzi G. Story-like organization of REM-dreams in patients with narcolepsy-cataplexy. *Brain Res Bull*. 2008;77(4):206-213.
18. Mazzetti M, Bellucci C, Mattarozzi K, Plazzi G, Tuozi G, Cipolli C. REM-dreams recall in patients with narcolepsy-cataplexy. *Brain Res Bull*. 2010; 81(1):133-140.
19. Nielsen T, Kuiken D, Hoffmann R, Moffitt. REM and NREM sleep mentation differences: a question of story structure? *Sleep Hypnos*. 2001; 3(1):9-17.
20. Cipolli C, Bolzani R, Tuozi G. Story-like organization of dream experience in different periods of REM sleep. *J Sleep Res* 1998;7(1): 13–19.
21. Pizza F, Moghadam KK, Vandi S, *et al*. Daytime continuous polysomnography predicts MSLT results in hypersomnias of central origin. *J Sleep Res*. 2013; 22(1): 32-40.
22. Vignatelli L, Plazzi G, Barbato A, *et al*. Italian version of the Epworth sleepiness scale: external validity. *Neurol Sci*. 2003; 23(6): 295–300.
23. Littner M, Kushida C, Wise M, *et al*. Practice parameters for clinical use of the multiple sleep latency test and the maintenance of wakefulness test. *Sleep* 2005; 28(1):113–121.

24. Vandi S, Pizza F, Antelmi E, *et al.* A standardized test to document cataplexy. *Sleep Med* 2019;53:197-204.
25. Mignot E, Lin L, Finn L, Lopes C, Pluff K, Sundstrom ML, Young T. Correlates of sleep-onset REM periods during the Multiple Sleep Latency Test in community adults. *Brain* 2006;129(6): 1609–23.
26. Wechsler D. *Wechsler Adult Intelligence Scale – Revised Manual*. The Psychological Corporation, Cleveland, 1981. (Italian translation: Giunti Organizzazioni Speciali, Firenze: 1997)
27. Wechsler D. *Wechsler Memory Scale-Revised Manual*. The Psychological Corporation, New York, 1987 (Italian translation: Giunti Organizzazioni Speciali, Firenze: 1994)
28. Foulkes D. Dream reports from different stages of sleep. *J Abn Soc Psychol.* 1962; 65: 14–25.
29. Cohen D. Failure to recall dream content: contentless vs dreamless reports. *Percept Mot Skills* 1972; 34(3): 1000–1002.
30. Iber C, Ancoli-Israel S, Chesson AL, *et al.* *The AASM manual for the scoring of sleep and associated events: rules, terminology, and technical specifications*. 1<sup>st</sup> ed. Westchester, IL: American Academy of Sleep Medicine; 2007
31. Hansen M, Kornum B, Jennum P. Sleep-wake instability in narcolepsy with normal, low and unmeasurable hypocretin levels. *Sleep Medicine* 2017; 34: 1-6.
32. Fazekas P, Nemeth G, Overgaard M. White dreams are made of colours: What studying contentless dreams can teach about the neural basis of dreaming and conscious experiences. *Sleep Med Rev.* 2019;43:84-91.
33. Siclari F, Baird B, Perogamvros L, *et al.* The neural correlates of dreaming. *Nat Neurosci.* 2017; 20(6): 872-878.
34. Mandler J, Johnson NS. Remembrance of things parsed: story structure and recall. *Cogn Psychol.* 1977; 9(1): 111–51.

35. Benbadis S, Wolgamuth BR, Perry MC, Dinner DS. Dreams and rapid eye movement sleep in the multiple sleep latency test. *Sleep* 1995;18(2):105-8.
36. Waihrich E, Rodrigues RN, Silveira HA, Fróes Fda F, Rocha GH. Comparative analysis of multiple sleep latency tests (MSLT) parameters and occurrence of dreaming in patients with daytime sleepiness of narcoleptic and non-narcoleptic origin. *Arq Neuropsiquiatr.* 2006; 64(4): 958-6.35.
37. Vogel G. Mentation reported from naps of narcoleptics. In: Guilleminault C, Dement W, Passouant P. (eds) *Narcolepsy*. New York: Spectrum; 1976:161–168.
38. Nielsen T (2010). Ultradian, circadian, and sleep-dependent features of dreaming. In M. Kryger, T. Roth, and W.C. Dement (Eds), *Principles and Practice of Sleep Medicine* (5th edition) New York: Elsevier; 2010: 576-584.
39. Cipolli C, Bolzani R, Cornoldi C, De Beni R, Fagioli I. Bizarreness effect in dream recall. *Sleep* 1993;16(2):163-170.
40. Foulkes D, Schmidt M. Temporal sequence and unit composition in dream reports from different stages of sleep. *Sleep* 1983; 6(3): 265–280.
41. Casagrande M, Cortini P. Spoken and written dream communication: differences and methodological aspects. *Conscious Cogn.* 2008; 17(1):145-158.
42. Snyder F. The phenomenology of dreaming. In: L. Meadow and L. H. Snow (Eds) *The psychodynamic implications of the physiological studies on dreams*. Thomas, Springfield, IL: 1970: 124–151.
43. Cipolli C, Guazzelli M, Bellucci C, et al. Time-of-night variations in the story-like organization of dream experience developed during rapid eye movement sleep. *J Sleep Res.* 2015;24(2):234-240.
44. Antrobus J, Kondo T, Reinsel R, Fein G. Dreaming in the late morning: summation of REM and diurnal cortical activation. *Conscious Cogn.* 1995;4(3):275-299.
45. Nielsen T, Stenstrom P, Takeuchi T, Saucier S, Lara-Carrasco J, Solomonova E, Martel E. Partial REM-sleep deprivation increases the dream-like quality of mentation from REM sleep and sleep onset. *Sleep* 2005;28(9):1083-1089.

46. Foulkes D. A cognitive–psychological model of REM dream production. *Sleep* 1982; 5(2): 169–187.
47. Foulkes D. *Dreaming: A cognitive-psychological analysis*. Erlbaum, Hillsdale, NJ: 1985.
48. Daltrozzo J, Claude L, Tillmann B, Mastuji H, Perrin F. Working memory is partially preserved during sleep. *PLoS ONE* 2012, 7: e50997.
49. Bastuji H, Perrin F, Garcia-Larrea L. Semantic analysis of auditory input during sleep: studies with event related potentials. *Int J Psychophysiol.* 2002;46(3): 243-255
50. Baylor GW, Cavallero C. Memory sources associated with REM and NREM dream reports throughout the night: a new look at the data. *Sleep* 2001;24(2):165-170.
51. Foulkes D, Domhoff GW. Bottom-up or top-down in dream neuroscience? A top-down critique of two bottom-up studies. *Conscious Cogn.* 2014;27:168-71.
52. Nir Y, Tononi G. Dreaming and the brain: from phenomenology to neurophysiology. *Trends Cogn Sci.* 2010;14(2):88-100.
53. Pace-Schott EF, Picchioni D (2017). The neurobiology of dreaming. In: M. Kryger, T. Roth, & W.C. Dement (Eds.), *Principles and Practice of Sleep Medicine* (6th edn). Philadelphia: Elsevier, 2017: 529-538..
54. Scrima L. Isolated REM sleep facilitates recall of complex associative information. *Psychophysiology* 1982;19(3):252-259.
55. Mazzetti M, Campi C, Mattarozzi K, *et al.* Semantic priming effect during REM-sleep inertia in patients with narcolepsy. *Brain Res Bull.* 2006;71(1-3): 270-278.
56. Stickgold R, Scott L, Rittenhouse C, Hobson JA. Sleep-induced changes in associative memory. *J Cogn Neurosci.* 1999;11(2): 182–193.
57. Lacaux C, Izabelle C, Santantonio G, *et al.* Increased creative thinking in narcolepsy. *Brain* 2019: 142(7):1988-1999.
58. Andrillon T, Poulsen AT, Hansen LK, Léger D, Kouider S. Neural markers of responsiveness to the environment in human sleep. *J Neurosci.* 2016; 36(24): 6583-6596.

59. Cipolli C, Ferrara M, De Gennaro L, Plazzi G. Beyond the neuropsychology of dreaming: Insights into the neural basis of dreaming with new techniques of sleep recording and analysis. *Sleep Med Rev.* 2017;35:8-20.

60. Dodet P, Chavez M, Leu-Semenescu S, Golmard JL, Arnulf I. Lucid dreaming in narcolepsy. *Sleep* 2015;38(3):487-497.

61. Dauvilliers Y, Schenck CH, Postuma RB, *et al.* REM sleep behaviour disorder. *Nat Rev Dis Primers* 2018;4(1):19.

62. Nielsen T. Dream mentation production and narcolepsy: a critique. *Conscious Cogn.* 2000; 9: 510-513.

Accepted Manuscript

## Figures

**Figure 1: Dygraph of Dream-Story N. 1 reported by a NT1 patient after a nap with SOREMP sleep.**

### **Statements of the part of verbal report corresponding to the dream-story.**

EE S1 I was hearing cable music in the background. ES S2 I found myself in the centre of a huge room, like a department store selling dreams. ES S3 every space was filled with counters selling all types of dreams. IE S4 I could choose, these things were available to me. IS S5 all these things were very pleasant. ES S6 at one counter there were kittens you could cuddle. ES S7 at another counter there were cartoons like The Smurfs. ES S8 at a more distant counter there were very handsome men like shop assistants to admire or dream of. EE S9 in the huge space I could move without really walking to get in the places I wanted. ES S10 the department store was around my head, I could reach out just with one arm. EE S11 I decided to dream about soft toys I invented in that moment. EE S12 all were soft toys (baby elephant, lion cub, puppy, kitten) with a robot inside and mimicked a hug. IE S13 I told myself: "I could sell these toys, apply for a patent". IE S14 then I thought "No, they look more like zombies". EE S15 (so) I went again on walking around. IE S16 (because) I want to see if there were weird cats like those in videos that roll about, fall down, meow. EE S17 and I saw some huge cats at one counter, I could stroke them or bring them home with me. IE S18 I thought "What big cats!". EE S19 (in this way) I ended my virtual visit. IE S20 Then I thought of my cat. IS S21 and I felt guilty. IE S22 I said to myself "Why don't you dream about your cat. ES S23 (the cat) is at home and hasn't seen you for three/four days?". EE S24 (then) my cat appeared, doing all her usual stuff in my garden, in my bedroom. EE S25 I played a bit with her. EE S26 I apologized for my absence. EE S27 (then) I went out.

**Legends:** BEG = Beginning; DEV = Development; END = Ending; CR = Complex Reaction; GP = Goal Path; SR = Simple Reaction; GL = Goal; ATT = Attempt; OUT = Outcome; ACT = Action; ES = External State; EE = External Event; IE = Internal Event; IS = Internal State. 0 = Constituent not realized in verbal report.



**Table 1- Values of psychometric measures (1a) and sleep parameters (1 b, 1c) of NT1 patients.**

	NT1 patients		F <sub>1,28</sub>	p
	Males	Females		
<b><u>1a Psychometric measures</u></b>				
WAIS-R Verbal IQ	107.43 ± 14.32	111.19 ± 9.27	0.747	0.395
WAIS-R Performance IQ	110.50 ± 13.44	109.12 ± 12.05	0.087	0.770
WAIS-R Total IQ	109.50 ± 13.41	111.37 ± 10.04	0.191	0.666
WMS total MQ	108.57 ± 13.60	114.62 ± 11.31	1.773	0.194
<b><u>1b. Night before MSLT</u></b>				
Time in Bed, <i>min</i>	497.78 ± 80.97	463.69 ± 106.05	0.957	0.336
Total Sleep Time, <i>min</i>	397.61 ± 71.14	400.78 ± 106.80	0.009	0.928
Sleep Efficiency %	80.01 ± 8.63	85.82 ± 9.45	3.058	0.091
N1, <i>min</i>	58.50 ± 20.98	52.22 ± 18.89	0.745	0.395
N2, <i>min</i>	182.96 ± 45.57	172.59 ± 53.12	0.324	0.574
N3, <i>min</i>	62.82 ± 23.06	77.78 ± 35.95	1.779	0.193
REM, <i>min</i>	93.32 ± 28.45	98.19 ± 35.04	0.171	0.682
WASO, <i>min</i>	95.64 ± 51.60	59.12 ± 39.85	4.471	<b>0.037 *</b>
Sleep Latency, <i>min</i>	4.53 ± 4.68	3.78 ± 3.51	0.253	0.619
REM Latency, <i>min</i>	34.03 ± 35.21	38.75 ± 51.17	0.084	0.774
<b><u>1c. MSLT trials (mean of 5 trials)</u></b>				
Time in Bed, <i>min</i>	18.68 ± 2.42	19.45 ± 2.31	0.810	0.376

Total Sleep Time, <i>min</i>	14.82 ± 1.06	15.64 ± 1.60	2.620	0.117
N1 <i>min</i>	3.88 ± 1.11	3.31 ± 1.64	1.219	0.279
N2, <i>min</i>	1.84 ± 1.95	4.33 ± 2.81	7.696	<b>0.010*</b>
N3. <i>min</i>	0.11 ± 0.34	0.39 ± 0.85	1.291	0.266
REM. <i>min</i>	8.98 ± 2.58	7.61 ± 3.65	1.376	0.251
WASO. <i>min</i>	1.41 ± 0.87	0.87 ± 0.60	4.041	0.054
Sleep Latency. <i>min</i>	2.55 ± 2.20	2.93 ± 2.34	0.201	0.657
N° SOREMP segments per SOREM nap	4.43 ± 0.85	3.87 ± 1.20	2.055	0.163

**Legends:** NT1, narcolepsy type 1;; WAIS-R, Wechsler Adult Intelligence Scale Revised; IQ, Intelligence Quotient; WMS,

Wechsler Memory Scale ; MQ, Memory Quotient. \* = p<0.05

Accepted Manuscript

**Table 2****2a. SOREMP duration, Number of SOREMP segments per nap and Sleep Stage**

before SOREMP sleep in the whole sample of NT1 patients.

**2b. SOREMP duration, Number of SOREMP segments per nap and Sleep Stage**

before SOREMP sleep in 16 NT1 patients with all SOREMP naps.

2a	NT1 patients (n = 30)						
	Naps with SOREMP	SOREMP Duration (min)	No. SOREMP segments	Transition to SOREMP from			
				WAKE	N1	N2	
NAP 1	28/30	11.08 ± 3.14	2.11 ± 1.31	1 (3.57%)	25 (89.29%)	2 (7.14%)	
NAP 2	24/30	10.10 ± 3.35	2.50 ± 1.50	1 (4.17%)	19 (79.17%)	4 (16.67%)	
NAP 3	26/30	8.61 ± 3.91	2.50 ± 1.53	1 (3.85%)	20 (76.92%)	5 (19.23%)	
NAP 4	23/29	9.86 ± 3.71	2.56 ± 1.47	0 (0%)	19 (82.61%)	4 (17.39%)	
NAP 5	23/30	10.19 ± 3.77	2.65 ± 1.27	1 (4.35%)	18 (78.26%)	4 (17.39%)	
<i>Mean</i>		<b>9.97 ± 0.89</b>	<b>2.46 ± 0.21</b>				
<i>Total</i>	<b>124/149</b> (96.12%)			4/124 (3.22%)	101/124 (81.45%)	19/124 (15.32%)	
2b	NT1 patients (n = 16)						
	NAP 1	16/16	12.23 ± 3.26	2.37 ± 1.54	1	15	0
	NAP 2	16/16	10.76 ± 3.06	2.81 ± 1.56	1	12	3
	NAP 3	16/16	9.29 ± 3.87	2.88 ± 1.50	1	13	2

<b>NAP 4</b>	<b>16/16</b>	10.80 ± 3.13	3.00 ± 1.51	0	14	2
<b>NAP 5</b>	<b>16/16</b>	9.49 ± 3.78	2.69 ± 1.08	0	13	3
<b>Mean</b>		<b>10.52 ± 2.15</b>	<b>2.75 ± 0.43</b>	<b>3.75%</b>	<b>83.75%</b>	<b>12.50%</b>
<b>Total</b>	<b>80/80</b> (100%)			3/80 (3.75%)	67/80 (83.75%)	10/80 (12.5%)

Accepted Manuscript

**Table 3 Occurrences of dream reports, white dreams and no dream in naps with SOREMP sleep and in naps with NREM sleep**

Trial	N. naps	N. SOREMP naps	Dream reports	White reports	No dream	N. NREM naps	Dream reports	White dreams	No dream
Trial 1	30	28	26	1	1	2	0	0	2
Trial 2	30	24	19	4	1	6	1	3	2
Trial 3	30	26	16	7	3	4	2	2	0
Trial 4	29	23	15	3	5	6	2	2	2
Trial 5	30	23	17	4	2	7	1	3	3
Total	149	124	93	19	12	25	6	10	9
% Naps	99.33	83.22	75.00	15.32	9.68	16.78	24.00	40.00	36.00
% Provoked Awakenings		90.32 (112 / 124)				88.00 (22 / 25)			

**Table 4-Indicators of length and structural organization of dream-stories in dream reports of NT1 patients.**

MS LT trial	Sample	Report Length	No.Stories	Story Length	Contextual organization	Sequential organization	Hierarchical organization
<b>4a: NT1 Patients with SOREMP naps</b>							
1	<i>n</i> = 26	21.73±1.294	1.81±0.80	13.32±8.48	2.49±1.51	10.83±7.41	2.62±1.88
2	<i>n</i> = 19	22.32±1.337	1.89±1.20	13.21±8.67	2.99±2.07	10.22±7.36	2.31±1.53
3	<i>n</i> = 16	19.69±1.911	1.62±0.81	11.72±10.36	2.04±1.44	9.68±9.24	2.14±1.75
4	<i>n</i> = 15	26.47±1.969	1.67±0.90	15.27±7.14	2.80±1.50	12.47±6.55	2.86±1.47
5	<i>n</i> = 17	16.29±1.349	1.53±0.72	10.44±7.08	2.35±1.63	8.09±6.49	2.08±1.42
<b>4b: NT1 Patients with NREM naps</b>							
1	<i>n</i> = /	/	/	/	/	/	/
2	<i>n</i> = 1	5.00±/	1.00±/	5.00±/	1.00±/	4.00±/	2.00±/
3	<i>n</i> = 2	9.00±2.83	1.50±0.70	6.25±1.06	2.50±2.12	3.75±1.06	1.00±0.00
4	<i>n</i> = 2	12.00±1.41	1.00±0.00	12.00±1.41	4.50±0.71	7.50±2.12	1.50±0.71
5	<i>n</i> = 1	5.00±/	1.00±/	5.00±/	2.00±/	3.00±/	2.00±/

**Table 5 Length and structural organization of dream-stories in dream reports provided by 8 NT1 patients after naps with SOREMP and the first-and third-cycle night REM sleep and by 21 NT1 patients after naps with SOREMP.**

	<b>SOREM naps 8 patients</b>	<b>SOREMP naps 21 patients</b>		<b>SOREM naps 8 patients</b>	<b>First-cycle REM Sleep 8 patients</b>	<b>Third-cycle REM Sleep 8 patients</b>	
<b>Indicators</b>			<b>F<sub>1,27</sub></b>				<b>F<sub>2,14</sub></b>
<b>N. Statements per report (report length)</b>	18.80 ± 6.32	19.84 ± 12.10	0.052; n.s.	18.80 ± 6.32	21.37 ± 12.87	20.12 ± 6.51	0.196; n.s.
<b>N. Dream-stories per report</b>	1.53± 0.44	1.73 ± 0.55	0.827; n.s.	1.53± 0.44	1.62 ± 0.52	1.75 ± 0.47	.518; n.s.
<b>N. Statements per dream-story (story length)</b>	12.65 ± 3.38	11.85 ± 6.21	0.119; n.s.	12.65 ± 3.38	12.750 ± 5.092	11.688 ± 3.342	0.541; n.s.
<b>N. Statements in Setting</b>	2.78 ± 1.20	2.39 ± 1.35	0.502; n.s.	2.78 ± 1.20	2.25 ± 0.53	2.31 ± 0.65	0.884; n.s.

<b>N. Statements in Event Structure</b>	9.87 ± 3.23	9.46 ± 5.49	0.040; n.s.	9.87 ± 3.23	10.50 ± 5.38	9.37 ± 3.07	0.208; n.s.
<b>N. Episodes per dream-story</b>	2.41 ± 0.92	2.19 ± 1.20	0.204; n.s.	2.41 ± 0.92	2.19 ± 1.19	1.94 ± 0.68	0.443; n.s.

Accepted Manuscript



Figure 1

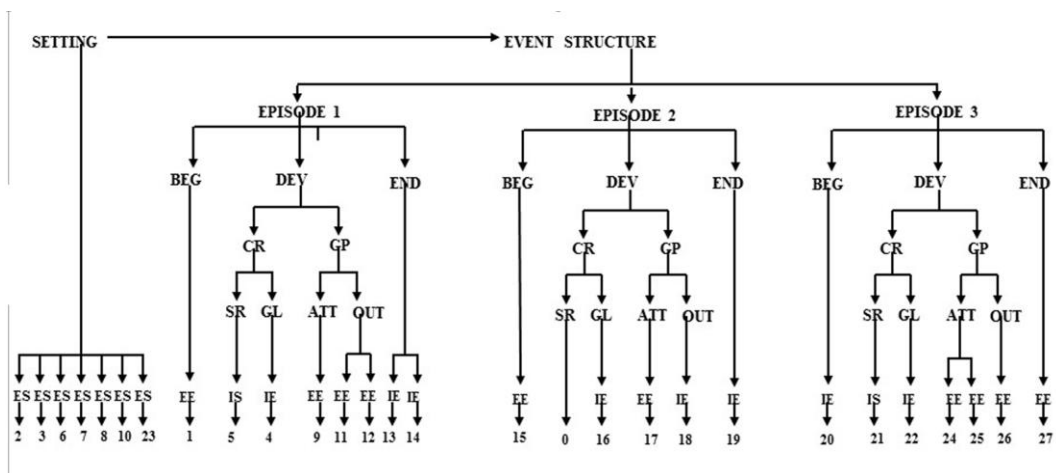

Accepted Manuscript