

This is a pre print version of the following article:

Asymmetric vibrations and chaos in spherical caps under uniform time-varying pressure fields / Iarriccio, G.; Zippo, A.; Pellicano, F.. - In: NONLINEAR DYNAMICS. - ISSN 0924-090X. - 107:1(2022), pp. 313-329. [10.1007/s11071-021-07033-7]

Terms of use:

The terms and conditions for the reuse of this version of the manuscript are specified in the publishing policy. For all terms of use and more information see the publisher's website.

16/05/2026 07:49

(Article begins on next page)

Asymmetric Vibrations and Chaos in Spherical Caps under Uniform Time-varying Pressure Fields

Giovanni Iarriccio (✉ giovanni.iarriccio@unimore.it)

UNIMORE: Università degli Studi di Modena e Reggio Emilia <https://orcid.org/0000-0001-9323-8656>

Antonio Zippo

UNIMORE: Università degli Studi di Modena e Reggio Emilia

Francesco Pellicano

UNIMORE: Università degli Studi di Modena e Reggio Emilia

Research Article

Keywords: Shells, spherical caps, vibrations, bifurcation, chaos

DOI: <https://doi.org/10.21203/rs.3.rs-657063/v1>

License:   This work is licensed under a Creative Commons Attribution 4.0 International License.

[Read Full License](#)

27 **Abstract**

28 *This paper presents a study on nonlinear asymmetric vibrations in shallow*
29 *spherical caps under pressure loading. The Novozhilov's nonlinear shell theory is*
30 *used for modelling the structural strains. A reduced-order model is developed*
31 *through the Rayleigh-Ritz method and Lagrange equations. The equations of*
32 *motion are numerically integrated using an implicit solver. The bifurcation*
33 *scenario is addressed by varying the external excitation frequency. The*
34 *occurrence of asymmetric vibrations related to quasi-periodic and chaotic motion*
35 *is shown through the analysis of time histories, spectra, Poincaré maps, and*
36 *phase planes.*

37

38 **Keywords**

39 *Shells, spherical caps, vibrations, bifurcation, chaos.*

40

41 **1. Introduction**

42 Thin-walled structures like plates, panels, shells, and caps are important structural
43 elements in Engineering; their applications can be found in Civil Engineering
44 (roofs, vaults, tensile structures), Aerospace (airplanes, missiles and rockets);
45 Mechanics (membrane based microsensors and energy harvesters).

46 These structures are strong and lightweight at the same time, but they are
47 extremely sensitive to perturbations, present a complicated instability behaviors
48 and are very difficult to model. They could buckle under the action of critical
49 loads, following sub-critical post-buckling paths; moreover, they can exhibit non-
50 linear dynamic phenomena, such as chaotic vibrations, when the amplitude of
51 vibration is moderately large.

52 Nowadays, many theories and simplified models are available for studying shell
53 systems, even in the presence of fluid-structure interaction or thermal fields.
54 Nevertheless, new challenges come from the new frontiers of the Engineering,
55 which asks for even more reliable models where complicating effects are taken
56 into account for exploiting the nonlinearities: for example, phenomena such as
57 multi-stability or the pull-in, can be desired features through which designers can
58 achieve structural optimization and develop high performance devices.

59 A short literature review is reported here for introducing the reader to the most
60 important and recent scientific contributions to the study of thin walled structures,
61 with a specific focus to spherical caps dynamics.

62 Concerning the elastic stability of shells, buckling problems are classified into:
63 Static buckling when loads are applied extremely slowly; Dynamic buckling when
64 the loads are suddenly applied (step loads).

65 From a literature review, there is a discrepancy between experimental data and
66 theoretical results. The primary sources of inconsistencies, that lead to an
67 experimental lower buckling load than the one theoretically predicted, are (i) the
68 high sensitivity of shells to geometric imperfections and non-uniform material
69 distribution, and (ii) the post-buckling behavior is strongly affected by
70 nonlinearities.

71 Let us first focus on the static instability of the spherical caps under an external
72 pressure load. Krenze and Kiernan [1] showed the importance of producing high
73 quality specimens for performing experimental tests. In the same period, Huang

74 [2] and Weinitsche [3] used Margurre's theory with possibility of having non-
75 symmetric buckling. They showed how, for deeper caps, the wavelength of the
76 buckling modes was higher compared to shallow caps, and numerical results
77 agreed with the experimental ones available at that time. These results were
78 experimentally confirmed by Yamada et al. [4] two decades later.

79 The role of geometric imperfections on critical static loads of caps was
80 investigated in Refs. [5,6]. Results pointed out how the shape of the geometric
81 imperfection affects the decrement of the critical buckling load; often the snap-
82 through phenomenon disappeared due to imperfections, and continuous and stable
83 buckling paths were shown by the pressure-deflection diagrams.

84 Since the measurement of imperfections it is not always possible for large scale
85 applications, NASA proposed an empirical formula based on the lower envelope
86 of a series of experimental data [7]. Nowadays, the specimens quality is higher
87 and other techniques have been proposed for improving the NASA empirical
88 formula[8,9].

89 A further reduction of the load-carrying capacity can be observed when the time
90 dependency of the load is considered, i.e. in the case of dynamic buckling.

91 Lock et al. [10] experimentally analyzed the buckling of shallow domes under a
92 pressure-step loading. They discussed the difference between "direct" and
93 "indirect" snapping phenomena. The direct snapping is a catastrophic
94 phenomenon and involves only symmetric vibrations; conversely, the indirect
95 snapping occurs after a transient and the contribution of the non-symmetric modes
96 is not negligible after the snapping.

97 Stricklin et al. [11] used nonlinear Novozhilov's theory for investigating the static
98 stresses in shells of revolution and improved their model for studying the dynamic
99 buckling in Ref. [12]. The equilibrium equations were obtained through
100 Castigliano's theorem. Numerical results were compared with experimental ones,
101 and an excellent agreement was proved. The dynamic model was derived
102 employing of the Lagrange equations by considering only axisymmetric modes,
103 and the results confirmed the previous analyses [13,14].

104 Ball and Burt [15] numerically investigated the dynamic buckling of clamped
105 shallow spherical caps under symmetric and nearly-symmetric step pressure loads.
106 Asymmetric modes were considered, and the buckling load of geometrically
107 perfect structures of different shallowness was given.

108 The asymmetric dynamic buckling of shallow spherical caps was investigated
109 even by Akkas [16], who showed that the asymmetric buckling under step
110 pressure load results in cusps in phase-plane diagrams.
111 Further results concerning the dynamic buckling of imperfect caps can be found in
112 Refs. [17–19], where the possibility of having plastic deformations was
113 considered as well.
114 In the framework of spherical caps under harmonic loads, the literature is not as
115 vast as for the buckling. Reasons must be sought in the fact that: (i) spherical caps
116 are a particular case of doubly curved shells, they are modeled through equations
117 that are more complex with respect to plates and cylindrical shells; (ii) the high
118 computational cost related to the numerical integration of the equations of motion
119 limited for long time the analysis to low dimensional models and axisymmetric
120 vibrations.
121 Using a theory proposed by Yu [20], Grossman et al. [21] investigated the
122 axisymmetric nonlinear vibrations of shallow spherical caps with different
123 boundary conditions. This study compared flat plates to curved caps, and the
124 results pointed out the transition from hardening to softening nonlinearity when
125 the surface curvature is increased.
126 Evensen and Iwanovsky [22] were the first to perform both analytically and
127 experimental analyses on shallow spherical caps under a combination of static and
128 sinusoidal external pressure loads. The analytical model was based on the
129 Marguerre’s nonlinear shell theory. Axisymmetric deflections and uniform load
130 distribution were considered. A detailed scheme of the experimental setup was
131 reported and discussed. Numerical results concerning free vibrations were in
132 excellent agreement with experiments. Unfortunately, differences were shown in
133 several nonlinear forced cases. Such discrepancies were mainly attributed to the
134 interaction between static and dynamic loads, and to the asymmetric vibrations
135 observed during the experiments.
136 Yasuda and Kushida [23] studied the forced vibration of caps under harmonic
137 point loads. The activation of subharmonic motion due to internal resonances was
138 observed. In order to validate the numerical model, experiments were performed
139 on a bent circular plate clamped at its edges. The structure was loaded by a
140 concentrated force induced by two electric magnets, and experimental results
141 agreed with the numerical ones.

142 The axisymmetric vibrations of pre-loaded shallow spherical caps were
143 investigated by Gonçalves [24,25] and Soliman and Gonçalves [26]. For obtaining
144 a reduced-order model (ROM), the Galerkin method was considered. The
145 displacement fields were expanded by using the Bessel functions, and the
146 resulting equations of motion were solved through the Newton-Rapson method.
147 Results showed a strong influence of geometric imperfections and their spatial
148 shape. Softening nonlinearity can be turned to hardening by imposing a suitable
149 initial imperfection of a given shape and amplitude, as shown by the reported
150 backbone curves. Moreover, assuming the excitation frequency as a control
151 parameter, the bifurcation analysis pointed out the existence of period-doubling
152 cascades and chaotic oscillations. The onset of such phenomena is due to energy
153 given by the harmonic pressure to the shell, which leads to multiple back-and-
154 forth jumps between potential wells.

155 Thomas et al. [27,28] studied the response of a free-edge shallow spherical cap
156 under harmonic excitation. Using the multiple-scale perturbation method, results
157 showed that, having integer or quasi-integer ratio between natural frequencies is
158 not a sufficient condition for having internal resonances activation. This is due to
159 the body symmetry, which leads to the canceling of some nonlinear coefficient in
160 the ODEs. Experiments were carried out by forcing the specimen using an
161 electromagnetic coil. The occurrence of an internal resonance between two
162 conjugate asymmetric modes and one axisymmetric mode (1:1:2) was proven, a
163 good qualitative fitting between theory and experiments was shown for small
164 forcing amplitude.

165 Touzè et al.[29,30] used the nonlinear normal modes approach (NNMs) for
166 predicting the trend of nonlinearity for each mode as a function of the spherical
167 cap geometric aspect ratios. In particular, the transition from hardening to
168 softening nonlinearity was addressed.

169 Chaotic vibrations in shallow shells with circular planform were investigated by
170 Krysko et al. [31]: the role of size-dependent parameters on vibrations of nano
171 shells were analyzed. The system of PDE was reduced using a finite difference
172 method (FDM), and the resulting system was solved through a Runge-Kutta
173 scheme. By comparing Fourier's spectra, Poincaré maps, Lyapunov exponents,
174 and Morlet wavelet, the authors showed that, considering the size-effect shells

175 exhibit regular vibrations whereas with the same load conditions neglecting the
176 size-effect one obtains chaotic vibrations.
177 The present work aims to address to some questions arisen recently in Ref.[32] on
178 pressure loaded spherical caps, where the limits of axisymmetric models were
179 shown using continuation techniques. Here the Novozhilov's geometrically
180 nonlinear theory is considered. For the analysis of the linearized equations, the
181 Rayleigh-Ritz approach is considered to obtain the mode shapes in a semi-
182 analytical way. Lagrange equations are used for reducing the system of nonlinear
183 partial differential equations, PDEs, to a system of ordinary differential equations,
184 ODEs. A bifurcation analysis of is carried out by directly integrating the equations
185 of motion. Results are presented and discussed with the help of bifurcation
186 diagrams and other useful tools, such as Poincaré maps and Fourier's spectra. The
187 superimposition of a static and a dynamic pressure yields to non-periodic and
188 chaotic oscillation related to the activation of asymmetric modes.

189

190 **2. Problem Formulation**

191 A spherical cap having radius R , base radius a , cap height s , and thickness h ,
192 is considered, see Fig. 1(a-c). A spherical coordinate system $(O; \varphi, \vartheta, z)$ is
193 centered at the top of the cap O . The curvilinear coordinates (φ, ϑ) identify a
194 point P of the shell middle surface, z is the radial distance of a generic point of
195 the shell from the middle surface. Three displacement fields, meridional
196 $u(\eta, \vartheta, t)$, circumferential $v(\eta, \vartheta, t)$, and radial $w(\eta, \vartheta, t)$, describe the deformed
197 configuration of the middle surface; t is the time variable.

198 Limiting the analysis to shallow spherical caps, the Lamé parameters of the
199 undeformed middle surface are $A_1 = R$ and $A_2 \cong \varphi_b \cdot \eta$; where $\eta = \varphi/\varphi_B$ is the
200 meridional non-dimensional coordinate.

201 For describing the relationships between strains and displacements, the
202 Novozhilov's nonlinear shell theory [33] is considered. Such theory is based on
203 the Kirchhoff-Love hypothesis, which states that: (i) the shell is thin $h \ll R$ and
204 $h \ll a$, (ii) strains, (iii) transverse normal stresses are small, and (iv) the normal to
205 the undeformed middle surface remains normal after deformation, and no

206 thickness stretching occurs. The hypothesis of small displacements is relaxed in
 207 the nonlinear analysis.
 208

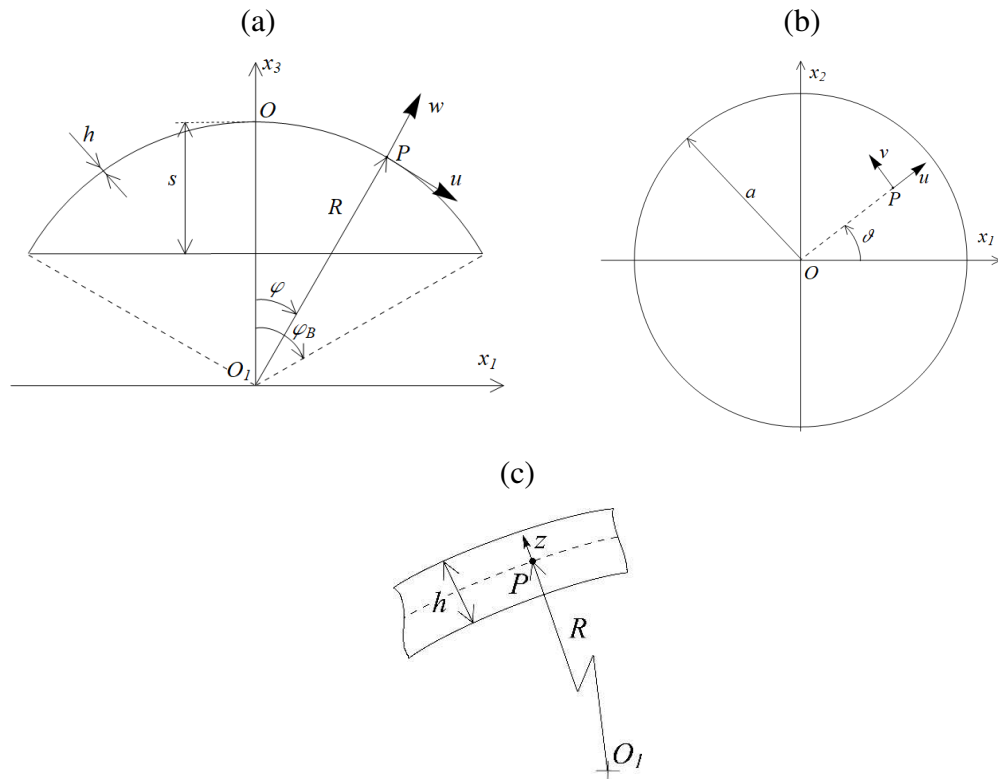

209 **Fig. 1. Spherical cap geometry and coordinate system: (a) cross-section view, (b) top view,**
 210 **and (c) breakout-section view.**

211

212 Because of the aforementioned hypothesis, the strains $\hat{\varepsilon}_i, \hat{\gamma}_{ij}$ at an arbitrary point
 213 of the cap linearly vary along the thickness; moreover, the plane-stress hypothesis
 214 is considered. The strains are given by:

215

$$\hat{\varepsilon}_\eta = \varepsilon_\eta + z \cdot k_\eta, \quad (1.a)$$

$$\hat{\varepsilon}_\vartheta = \varepsilon_\vartheta + z \cdot k_\vartheta, \quad (1.b)$$

$$\hat{\gamma}_{\eta\vartheta} = \gamma_{\eta\vartheta} + z \cdot k_{\eta\vartheta}, \quad (1.c)$$

216

217 where $\varepsilon_\eta, \varepsilon_\vartheta, \gamma_{\eta\vartheta}$ are the middle surface strains, $k_\eta, k_\vartheta,$ and $k_{\eta\vartheta}$ are the changes
 218 in curvatures and torsion of the middle surface of the shell, which depend on the
 219 middle surface displacement fields through the following relationships:

220

$$\varepsilon_\eta = e_{11} + \frac{1}{2}(e_{11}^2 + e_{12}^2 + e_{13}^2), \quad (2.a)$$

$$\varepsilon_\vartheta = e_{22} + \frac{1}{2}(e_{21}^2 + e_{22}^2 + e_{23}^2), \quad (2.b)$$

$$\gamma_{\eta\vartheta} = e_{12} + e_{21} + e_{11}e_{21} + e_{12}e_{22} + e_{12}e_{23}, \quad (2.c)$$

$$k_\eta = -\frac{1}{A_1} \frac{\partial e_{13}}{\varphi_b \partial \eta} + \frac{e_{11} + e_{22}}{R}, \quad (2.d)$$

$$k_\vartheta = -\frac{1}{A_1 A_2} \frac{\partial A_2}{\varphi_b \partial \eta} e_{13} + \frac{1}{A_1} \frac{\partial e_{23}}{\varphi_b \partial \eta} + \frac{e_{11} + e_{22}}{R}, \quad (2.e)$$

$$k_{\eta\vartheta} = -\frac{1}{A_2} \frac{\partial e_{13}}{\partial \vartheta} - \frac{1}{A_1} \frac{\partial e_{23}}{\varphi_b \partial \eta} + \frac{1}{A_1 A_2} \frac{\partial A_2}{\varphi_b \partial \eta} e_{23}. \quad (2.f)$$

221

222 where the strain components e_{ij} are:

223

$$e_{11} = \frac{1}{A_1} \frac{\partial u}{\varphi_b \partial \eta} + \frac{w}{R}, \quad (3.a)$$

$$e_{12} = \frac{1}{A_2} \frac{\partial u}{\partial \vartheta} - \frac{1}{A_1 A_2} \frac{\partial A_2}{\varphi_b \partial \eta} v, \quad (3.b)$$

$$e_{13} = -\frac{u}{R} + \frac{1}{A_1} \frac{\partial w}{\varphi_b \partial \eta}, \quad (3.c)$$

$$e_{21} = \frac{1}{A_1} \frac{\partial v}{\varphi_b \partial \eta}, \quad (3.d)$$

$$e_{22} = \frac{1}{A_1 A_2} \frac{\partial A_2}{\varphi_b \partial \eta} u + \frac{1}{A_2} \frac{\partial v}{\partial \vartheta} + \frac{w}{R}, \quad (3.e)$$

$$e_{23} = -\frac{v}{R} + \frac{1}{A_2} \frac{\partial w}{\partial \vartheta}. \quad (3.f)$$

224

225 Considering an elastic linear, homogeneous and isotropic continuum, one can use

226 the Hooke's law, i.e. the following stress-strain relationships:

227

$$\begin{pmatrix} \hat{\sigma}_\eta \\ \hat{\sigma}_g \\ \hat{\tau}_{\eta g} \end{pmatrix} = \begin{bmatrix} \frac{E}{1-\nu^2} & \frac{\nu E}{1-\nu^2} & 0 \\ \frac{\nu E}{1-\nu^2} & \frac{E}{1-\nu^2} & 0 \\ 0 & 0 & \frac{E}{2(1+\nu)} \end{bmatrix} \begin{pmatrix} \hat{\varepsilon}_\eta \\ \hat{\varepsilon}_g \\ \hat{\gamma}_{\eta g} \end{pmatrix} \quad (4.a)$$

228

229 where E and ν are the Young's modulus and the Poisson's ratio, respectively.

230 By considering the strains (1.a-d) and the stresses (4.a-b), the elastic strain energy

231 U_s [34] of a thin shallow spherical cap is given by

232

$$\begin{aligned} U_s &= \frac{1}{2} \int_{-h/2}^{h/2} \int_{\eta_0}^1 \int_0^{2\pi} (\hat{\sigma}_\eta \hat{\varepsilon}_\eta + \hat{\sigma}_g \hat{\varepsilon}_g + \hat{\tau}_{\eta g} \hat{\gamma}_{\eta g}) A_1 A_2 \varphi_b d\vartheta d\eta \\ &= \frac{1}{2} \frac{Eh}{1-\nu^2} \int_{\eta_0}^1 \int_0^{2\pi} \left(\varepsilon_\eta^2 + \varepsilon_g^2 + 2\nu \varepsilon_\eta \varepsilon_g + \frac{1-\nu}{2} \gamma_{\eta g}^2 \right) A_1 A_2 \varphi_b d\vartheta d\eta + \\ &\quad \frac{1}{2} \frac{Eh^3}{12(1-\nu^2)} \int_{\eta_0}^1 \int_0^{2\pi} \left(k_\eta^2 + k_g^2 + 2\nu k_\eta k_g + \frac{1-\nu}{2} k_{\eta g}^2 \right) A_1 A_2 \varphi_b d\vartheta d\eta \end{aligned} \quad (5)$$

233

234 while, the kinetic energy T_s , under the hypothesis of negligible rotary inertia [34],

235 is given by

236

$$T_s = \frac{1}{2} \rho_s h \int_{\eta_0}^1 \int_0^{2\pi} (\dot{u}^2 + \dot{v}^2 + \dot{w}^2) A_1 A_2 \varphi_b d\vartheta d\eta \quad (6)$$

237

238 where ρ_s is the material mass density, η_0 is the half opening angle of a hole

239 assumed at the cap pole for avoiding the singularity due to the spherical reference

240 system [35].

241

242 2.1. Approximate eigenfunctions

243 In order to develop a ROM for studying the cap nonlinear dynamics, in this

244 section the eigenfunctions of the linearized operator are obtained through the

245 Rayleigh-Ritz approach [36].

246 In the present study, clamped boundary conditions are considered at the circular
 247 edge

$$u = v = w = \frac{\partial w}{\partial \eta} = 0 \quad \text{for} \quad \eta = 1 \quad (7)$$

248 while, no boundary conditions are considered at the cap pole.

249 The Rayleigh-Ritz approach requires that a trial function set respects the
 250 geometric boundary conditions only [37]; on the other hand, the stress-free
 251 boundary conditions at the cap pole (where the small hole is present) are
 252 neglected.

253 The generic mode of vibration can be described by considering three displacement
 254 fields $u(\eta, \vartheta, t)$, $v(\eta, \vartheta, t)$, and $w(\eta, \vartheta, t)$, which obey to the same time law $f(t)$,
 255 i.e. the variable separation can be considered:

256

$$u(\eta, \vartheta, t) = U(\eta, \vartheta) \cdot f(t), \quad (8.a)$$

$$v(\eta, \vartheta, t) = V(\eta, \vartheta) \cdot f(t), \quad (8.b)$$

$$w(\eta, \vartheta, t) = W(\eta, \vartheta) \cdot f(t). \quad (8.c)$$

257

258 $U(\eta, \vartheta)$, $V(\eta, \vartheta)$, and $W(\eta, \vartheta)$ are spatial functions denoting the mode shapes i.e.
 259 eigenfunctions.

260 The eigenfunctions are now discretized using a linear combination of functions.
 261 Legendre polynomials are considered in the meridional direction and
 262 trigonometric functions are assumed in the circular direction.

263

$$U(\eta, \vartheta) = \sum_{m=0}^{M_u} \sum_{n=0}^N \tilde{U}_{m,n} P_m^*(\eta) \cos(n\vartheta), \quad (9.a)$$

$$V(\eta, \vartheta) = \sum_{m=0}^{M_v} \tilde{V}_{m,0} P_m^*(\eta) + \sum_{m=0}^{M_v} \sum_{n=1}^N \tilde{V}_{m,n} P_m^*(\eta) \sin(n\vartheta), \quad (9.b)$$

$$W(\eta, \vartheta) = \sum_{m=0}^{M_w} \sum_{n=0}^N \tilde{W}_{m,n} P_m^*(\eta) \cos(n\vartheta). \quad (9.c)$$

264

265 where $P_m^*(\eta) = P_m(2\eta - 1)$ is the m -th Legendre polynomial of the first kind
 266 shifted in the domain $\eta \in [0, 1]$; m is related to the number of meridional
 267 wavelength; n is the number of nodal diameters.

268 Because of the axial symmetry, spherical caps exhibit conjugate modes, called
 269 driven and companion mode shapes or conjugate modes [38,39]. These modes
 270 have the same natural frequency and shape, but the displacement fields are
 271 angularly shifted of $\pi/2n$. Conjugate modes describe standing waves, but
 272 circumferential travelling waves could arise when nonlinear mode coupling
 273 occurs [40–42]. Therefore, companion modes should be considered when a
 274 nonlinear analysis is carried out.

275

$$U(\eta, \mathcal{G}) = \sum_{m=0}^{M_u} \sum_{n=1}^N \tilde{U}_{m,n} P_m^*(\eta) \sin(n\mathcal{G}), \quad (10.a)$$

$$V(\eta, \mathcal{G}) = \sum_{m=0}^{M_v} \sum_{n=1}^N \tilde{V}_{m,n} P_m^*(\eta) \cos(n\mathcal{G}), \quad (10.b)$$

$$W(\eta, \mathcal{G}) = \sum_{m=0}^{M_w} \sum_{n=1}^N \tilde{W}_{m,n} P_m^*(\eta) \sin(n\mathcal{G}). \quad (10.c)$$

276

277 It is worth noting that asymmetric modes are not associated to multiple
 278 eigenvalues, therefore, they have not companion modes.

279 By imposing the set of boundary conditions (7) to the discretized eigenfunctions,
 280 a system of algebraic equations is obtained:

281

$$\sum_{m=0}^{M_u} \tilde{U}_{m,n} P_m^*(\eta) = 0, \quad (12.a)$$

$$\sum_{m=0}^{M_v} \tilde{V}_{m,n} P_m^*(\eta) = 0, \quad (12.b)$$

$$\sum_{m=0}^{M_w} \tilde{W}_{m,n} P_m^*(\eta) = 0, \quad \text{for } \eta=1 \quad (12.c)$$

$$\sum_{m=0}^{M_w} \tilde{W}_{m,n} \frac{\partial}{\partial \eta} P_m^*(\eta) = 0, \quad (12.d)$$

282

283 The solution of this linear system allows to express $(\tilde{U}_{0,n}, \tilde{V}_{0,n}, \tilde{W}_{0,n}, \tilde{W}_{1,n})$ in terms
 284 of the remaining coefficients $(\tilde{U}_{m,n}, \tilde{V}_{m,n}, \tilde{W}_{m,n})$; the latter coefficients can be

285 reordered in a vector $\tilde{\mathbf{q}}$ [43] with a number of elements equal to
 286 $N_{max} = (M_u + M_v + M_w + 3 - b)(N + 1)$, where $b=4$ for a clamped circular cap [32].
 287 Considering only the linear terms in the strain-displacement relations (2.a-f), the
 288 eigenvalue problem for approximating the natural frequencies and mode shapes of
 289 the structure is obtained by imposing the stationarity of the Rayleigh's quotient
 290 $R(\tilde{\mathbf{q}}) = U_s(\tilde{\mathbf{q}})/T_s^*(\tilde{\mathbf{q}})$, where $U_s(\tilde{\mathbf{q}})$ is the maximum potential energy during a
 291 "modal" oscillation, and $T_s^*(\tilde{\mathbf{q}}) = T_s(\tilde{\mathbf{q}})/\omega^2$.

292

$$(-\omega^2 \mathbf{M} + \mathbf{K})\tilde{\mathbf{q}} = \mathbf{0}. \quad (13)$$

293

294 ω is the circular frequency of the harmonic motion; \mathbf{M} and \mathbf{K} are the mass
 295 matrix and the stiffness matrix of the discrete linearized system, respectively.

296 The i -th solution of equation (13), $(\omega^{(i)}, \tilde{\mathbf{q}}^{(i)})$, gives the approximation of the i -th
 297 natural frequency and mode shape, respectively.

298 To improve the results readability and the numerical accuracy, the approximated
 299 mode shapes are normalized using the approach of Ref.[43], and the following
 300 condition is sought $\max[\text{abs}[U^{(i)}(\eta, \vartheta)], \text{abs}[V^{(i)}(\eta, \vartheta)], \text{abs}[W^{(i)}(\eta, \vartheta)]] = 1$.

301

302 **2.2 Nonlinear vibrations**

303 Synchronous motion and small amplitude displacement hypotheses are now
 304 relaxed, as well as the absence of external excitation.

305 In such conditions we cannot claim anymore that the vibration is harmonic or
 306 periodic.

307 The approach used for analyzing the nonlinear dynamics of the cap is based on the
 308 spectral theorem, i.e., taking advantage from the completeness of the
 309 eigenfunctions calculated on the previous section, the displacement fields are
 310 expanded as follows:

311

$$u(\eta, \vartheta, t) = \sum_i^{M_u} \sum_j^{N_u} [U_{i,j}^{(d)}(\eta, \vartheta) f_{u,i,j}^{(d)}(t) + U_{i,j}^{(c)}(\eta, \vartheta) f_{u,i,j}^{(c)}(t)] \quad (14.a)$$

$$v(\eta, \vartheta, t) = \sum_i^{M_v} \sum_j^{N_v} [V_{i,j}^{(d)}(\eta, \vartheta) f_{v,i,j}^{(d)}(t) + V_{i,j}^{(c)}(\eta, \vartheta) f_{v,i,j}^{(c)}(t)] \quad (14.b)$$

$$w(\eta, \vartheta, t) = \sum_i^{M_{w,1}} \sum_j^{N_w} [W_{i,j}^{(d)}(\eta, \vartheta) f_{w,i,j}^{(d)}(t) + W_{i,j}^{(c)}(\eta, \vartheta) f_{w,i,j}^{(c)}(t)] \quad (14.c)$$

312

313 where d and c are related to the driven and companion modes, respectively; i and j
 314 identify the number of meridional and circumferential wavelengths; $f_{k,i,j}^{(\cdot)}$ are the
 315 time dependent unknown generalized coordinates.

316 For thin-walled bodies under external pressure load, two assumptions are common
 317 in the literature: (i) the pressure is considered as a radial non-follower load; (ii)
 318 the load distribution is applied to the middle surface [33].

319 The former approximation simplifies the numerical calculations and reduces the
 320 numerical effort; however, it could underestimate the safety factor in structures
 321 that undergo to large deflections. The latter assumption is a valid approximation
 322 for thin shells and should be removed for thicker structures.

323 Considering a configuration-dependent pressure distribution that always acts
 324 orthogonal to the surface (follower force distribution), the expression of the j -th
 325 generalized force is given by Amabili and Breslavsky, where only the linear strain
 326 terms are retained [44]

327

$$\frac{\partial W_p}{\partial q_j} \cong \int_{\eta_0}^1 \int_0^{2\pi} p(t) \left[-\frac{\partial u}{\partial q_j} e_{12} - \frac{\partial v}{\partial q_j} e_{23} + -\frac{\partial w}{\partial q_j} (1 + e_{11} + e_{22}) \right] A_1 A_2 \varphi_b d\vartheta d\eta, \quad (15)$$

328

329 The external pressure consists of a static and a dynamic component
 330 $p(t) = p_s + p_d \cos(\Omega t)$ is the external pressure. The pressure is positive when
 331 inflates the structure.

332 Taking into account the full expression of the strains (2.a-f) and replacing them
 333 into the energies and virtual work formulae, the equations of motion are derived
 334 by the Lagrange equations

335

$$\frac{d}{dt} \left(\frac{\partial T_s}{\partial \dot{q}_j} \right) + \frac{\partial U_s}{\partial q_j} = \frac{\partial W_p}{\partial q_j}, \quad \text{for } j=1, 2, \dots, N_{dofs} \quad (16)$$

336

337 N_{dofs} indicates the number of degrees of freedom of the nonlinear ODEs. Such set
 338 could be rewritten into state-space form.

339 The set of nonlinear ODEs could be rewritten into the following first-order form:

340

$$\begin{cases} \dot{\mathbf{q}} = \mathbf{y} \\ \dot{\mathbf{y}} = \mathbf{M}^{-1}[-\mathbf{C}\mathbf{y} - \mathbf{K}_{NL}\mathbf{q} + \mathbf{p}_s + \mathbf{p}_d \cos(\Omega t)] \end{cases} \quad (17)$$

341

342 Note that $\mathbf{M}^{-1}\mathbf{C} = \text{diag}(2\zeta_j\omega_j)$, where ζ_j and ω_j are the damping ratio and the
 343 natural frequencies of the j^{th} generalized coordinate; \mathbf{p}_s and \mathbf{p}_d are the
 344 generalized force vectors due to the static and dynamic pressure, respectively; Ω
 345 is the frequency of the external excitation; \mathbf{y} is the generalized velocity vector.

346 In the following analysis, the equations of motion are reduced to a
 347 nondimensional form: the amplitudes are divided by the shell thickness; the time
 348 is divided by the period of the first axisymmetric resonant mode.

349

$$\hat{\mathbf{q}} = \mathbf{q}/h \quad \tau = \omega_{1,0} \cdot t \quad (18)$$

350

351 The pressure is normalized through to the Zoelly's critical buckling pressure of a
 352 complete, isotropic, and homogeneous sphere, see Ref. [45]

353

$$p_{cr} = \frac{2E}{\sqrt{3(1-\nu^2)}} \left(\frac{h}{R}\right)^2 \quad (19)$$

354

355 For the sake of completeness, the expression of the parameter λ is here reported
 356 due to its important meaning: λ includes information on the thinness and the
 357 shallowness of the investigated structure.

358

$$\lambda = \sqrt[4]{12(1-\nu^2)} \cdot \frac{a}{\sqrt{Rh}}, \quad (20)$$

359

360 **3. Numerical Results**

361 Consider a clamped shallow spherical cap, having a uniform thickness, made of
 362 steel. Using the 38 *dofs* nonlinear model developed in Ref [32], the nonlinear
 363 dynamic response of the cap under a time-varying harmonic pressure is

364 investigated. For the sake of clarity, the linear mode shapes retained into the
 365 nonlinear ROM are listed in Table 1: it must be noted that both driven and
 366 companion vibration modes have been included for the asymmetric mode shapes
 367 ($n=0$).

368

369 **Table 1 – Normalized natural frequencies and mode shapes considered into the nonlinear**
 370 **reduced-order model [32].**

$\omega_{m,n} / \omega_{1,0}$	m	n	<i>Modal displacement field</i>
1.0000	1	0	w, u
1.1052	1	2	w, v, u
1.3030	2	0	w, u
1.6838	1	4	v
1.9650	2	2	w, v, u
2.0695	3	0	w, u
2.4869	2	4	v
2.6661	3	2	w, v, u
3.4519	4	0	w, u
4.1146	3	4	v
5.3040	5	0	w, u
7.3148	4	4	v
7.7524	6	0	w, u

371

372 The geometrical and structural data are listed as follows: $R = 0.8 \text{ m}$, $h = R/300$,
 373 $a = 0.152 \text{ m}$, $s = 0.0147 \text{ m}$, $\varphi_b = 11.0 \text{ deg}$, $E = 200 \cdot 10^9 \text{ Pa}$, $\rho = 7800 \text{ kg/m}^3$,
 374 $\nu = 0.3$, $\lambda = 6$. The natural frequency of the first axisymmetric mode, $\omega_{1,0}$, is
 375 considered for the time nondimensionalization, as already stated in (18), and a
 376 modal damping factor $\zeta_j = 0.012$, $j = 1, 2, \dots, N_{dofs}$ is assumed.

377 A static pressure load $p_s = -0.40 \cdot p_{cr}$ (lower than the critical buckling pressure)
 378 acts on the shell while a dynamic component, of amplitude $p_d = 0.020 \cdot p_{cr}$, is
 379 superimposed to the static one.

380 The set of nonlinear ODEs (17) is numerically solved by using the Fortran routine
 381 for time integration RADAU5 [46]. This integrator was developed for solving stiff
 382 ODEs and is based on the implicit Runge-Kutta method of order 5, 3-stages, with

383 step-size control. To carry out the bifurcation analysis, the excitation frequency is
384 varied forward and backward in the frequency range $\Omega/\omega_{1,0} \in [1.07400, 1.10500]$,
385 where the occurrence of dynamic instabilities were proven through a path-
386 following analysis in Ref. [32].

387 The parameters used for setting the time-response analysis are the following: 125
388 excitation frequency steps with a step-size of $\Delta\Omega/\omega_{1,0} = \pm 0.00025$; a sampling
389 frequency equal to 40 times the excitation frequency; 600 excitation periods of
390 integration, where only 300 periods are retained for getting rid of the transient
391 response. When the simulation starts, homogeneous initial conditions are
392 considered, then, for further steps (different frequencies), the initial conditions are
393 assumed to be the final state of the previous step, with a perturbation of amplitude
394 0.01 (dimensionless) applied to every generalized coordinate. For the frequencies
395 where the system is sensitive to small perturbations and prone to exhibits chaotic
396 motion, the perturbation allows the system to leave an almost unstable orbit and
397 find remote attractors.

398 In Fig. 2(a,b), the frequency-response curves obtained by directly integrating the
399 ODEs are compared to continuation method results [32]. Starting from
400 $\Omega/\omega_{1,0} = 1.0740$ and considering an increasing forcing frequency (red asterisks),
401 $f_{w,1,0}$ follows the stable solution path 1 (continuous black line) and switch on
402 branch 2 after the period-doubling (PD) at $\Omega/\omega_{1,0} = 1.08275$, see Fig. 2(a), where
403 the bifurcation leads to the onset of asymmetric oscillations, see Fig. 2(b). Large
404 amplitude vibrations, with a discontinuous amplitude variation, occur for
405 $\Omega/\omega_{1,0} \in [1.08425, 1.09375]$, where the path following analysis pointed out the
406 coexistence of multiple unstable solution (dotted black line), i.e. one or more
407 Floquet multipliers fall outside the unit circle. By considering $\Omega/\omega_{1,0} > 1.09500$,
408 $f_{w,1,0}$ lies again on a stable periodic solution, while $f_{w,1,2}^{(d)}$ follows a branch not
409 shown in Ref. [32] and asymmetric oscillations persists until a second PD
410 bifurcation at $\Omega/\omega_{1,0} = 1.10125$.

411 Considering now a backward frequency variation (blue circles), the frequency-
412 response curve trend is almost the same obtained by considering an upward
413 frequency variation. However, when the harmonic pressure acts on the structure
414 with a frequency $\Omega/\omega_{1,0} \in [1.07650, 1.08400]$, both the coordinates $f_{w,1,0}$ and $f_{w,1,2}^{(d)}$

415 follows secondary solution branches not shown by the path following analysis
 416 [32]. A further reduction of the forcing frequency, leads to a sudden response
 417 jump that restores a purely axisymmetric overall motion of the cap.
 418

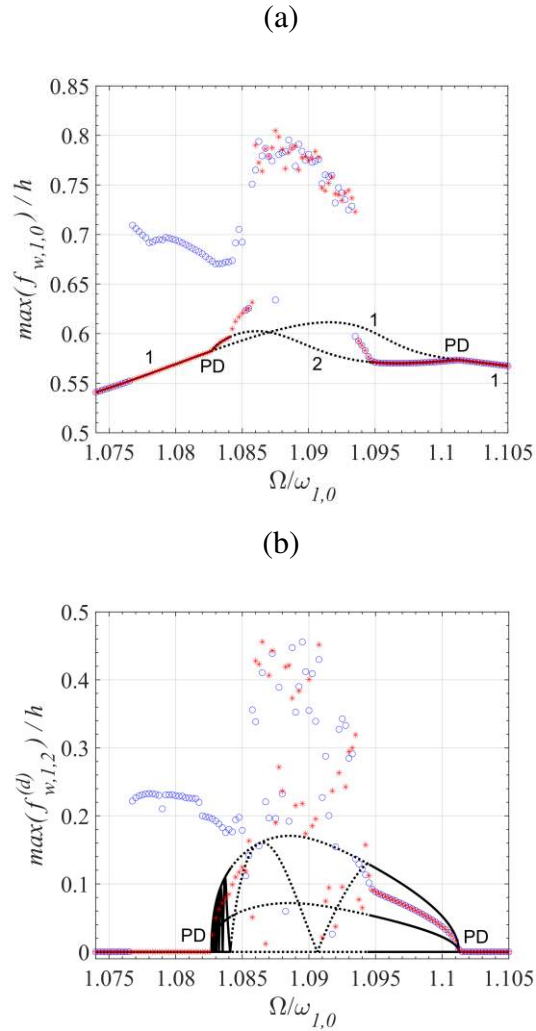

419 **Fig. 2. Frequency-response curves: (a) first axisymmetric mode, (b) driven asymmetric mode**
 420 **(1,2). (- Ref.[32], * upward frequency variation, o downward frequency variation, “PD”**
 421 **period-doubling).**
 422

423 In order to provide further information for understanding the path-following
424 analysis results, bifurcation diagrams of the Poincaré maps are here presented and
425 discussed.

426 In Fig. 3(a-d), the bifurcation diagrams obtained for an increasing excitation
427 frequency are shown. The response is fully axisymmetric until $\Omega/\omega_{1,0} = 1.08275$,
428 where the activation of the asymmetric conjugate modes $f_{w,1,2}^{(d)}$ and $f_{w,1,2}^{(c)}$ is
429 governed by 2-T subharmonic responses, see Fig. 3(c,d), although the
430 axisymmetric generalized coordinates $f_{w,1,0}$ and $f_{w,2,0}$ retain 1-T periodic
431 oscillations, Fig. 3(a, b). Nonperiodic vibrations arise for $\Omega/\omega_{1,0} = 1.08425$, where
432 a Neimark-Sacker bifurcation leads to amplitude-modulated oscillations. For
433 $\Omega/\omega_{1,0} = 1.08600$, the quasi-periodic response collapse on a chaotic attractor.
434 Chaotic region holds until $\Omega/\omega_{1,0} = 1.94250$, where quasi-periodic motion is
435 restored and the conjugated asymmetric coordinates $f_{w,1,2}^{(d)}$ and $f_{w,1,2}^{(c)}$ display 2-T
436 periodic oscillations. An additional excitation frequency increment gives rise to a
437 period-doubling bifurcation at $\Omega/\omega_{1,0} = 1.10125$, in agreement with the finding of
438 [32]. Beyond the period doubling, the response becomes periodic with the same
439 frequency of the excitation and the contribution of the asymmetric modes on the
440 overall oscillation becomes null, as already pointed out from the analysis of the
441 frequency-response diagrams in Fig. 2(a,b).

442 Bifurcation diagrams of the Poincaré sections are now analyzed by considering a
443 decreasing excitation frequency, Fig. 4(a-d).

444 Starting from $\Omega/\omega_{1,0} = 1.10500$, the structural response undergoes sequentially to
445 a period-doubling bifurcation at $\Omega/\omega_{1,0} = 1.10125$ and a Neimark-Sacker
446 bifurcation at $\Omega/\omega_{1,0} = 1.09450$. The amplitude-modulated oscillations burst into a
447 chaotic attractor at $\Omega/\omega_{1,0} = 1.09325$. Inside the range
448 $\Omega/\omega_{1,0} \in [1.08500, 1.09325]$, the response jumps from chaotic to quasi-periodic
449 attractors. A further reduction of the control parameter leads to a complex
450 dynamic behavior, where the solution alternates quasi-periodic to 5T-subharmonic
451 vibrations. Then, when $\Omega/\omega_{1,0} < 1.07650$, only axisymmetric states exist.

452

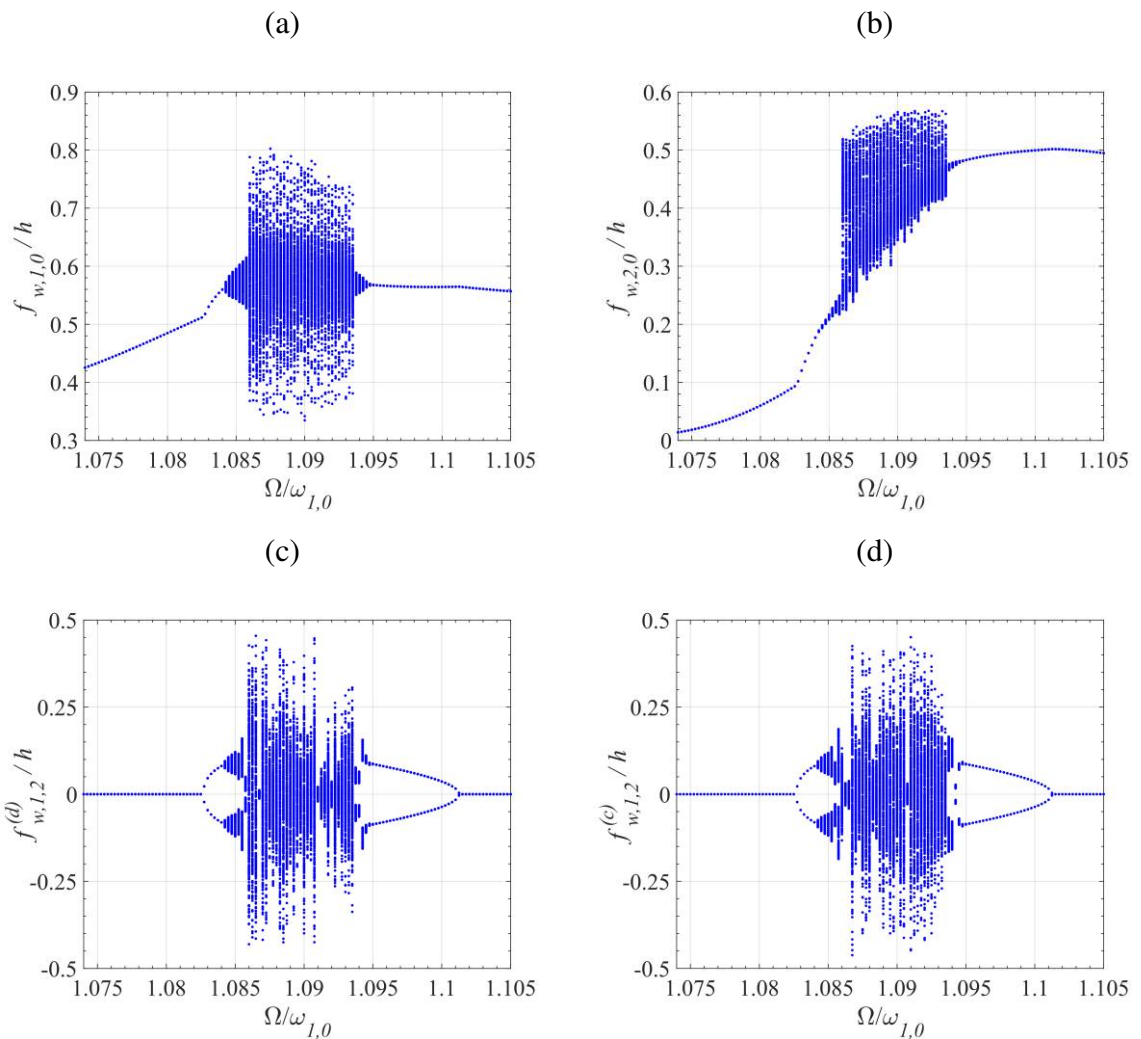

454 **Fig. 3 - Bifurcation diagrams of the Poincaré section for an increasing excitation frequency:**
 455 **(a) first axisymmetric mode, (b) second axisymmetric mode, (c) driven, and (d) companion**
 456 **asymmetric modes (1,2).**

457

458 From the analysis of the bifurcation diagrams, an interesting phenomenon has
 459 been pointed out: for some values of the forcing frequency, axisymmetric
 460 vibrations are periodic with the same frequency of the harmonic pressure, while
 461 the asymmetric oscillations are 2-T subharmonic. By analyzing the set of the
 462 equations, one could see that a coupling between linear terms of the coordinate
 463 $f_{w,1,0}$ and $f_{w,1,2}^{(d)}$ is missing in the first equation of the ODEs (when a perfect
 464 structure is considered). On the other hand, only odd powers of $f_{w,1,2}^{(d)}$ and products
 465 between linear power of $f_{w,1,0}$ and $f_{w,1,2}^{(d)}$ appear in the second equation; therefore,
 466 an autoparametric instability takes place when the axisymmetric mode (1,0)

467 vibrates at the same frequency of the asymmetric mode (1,2), indeed, from Figs.
 468 3-4, a period-doubling occurs when $\Omega/\omega_{1,0} = 1.10125$, i.e. $\Omega/\omega_{1,2} = 0.9964$.
 469

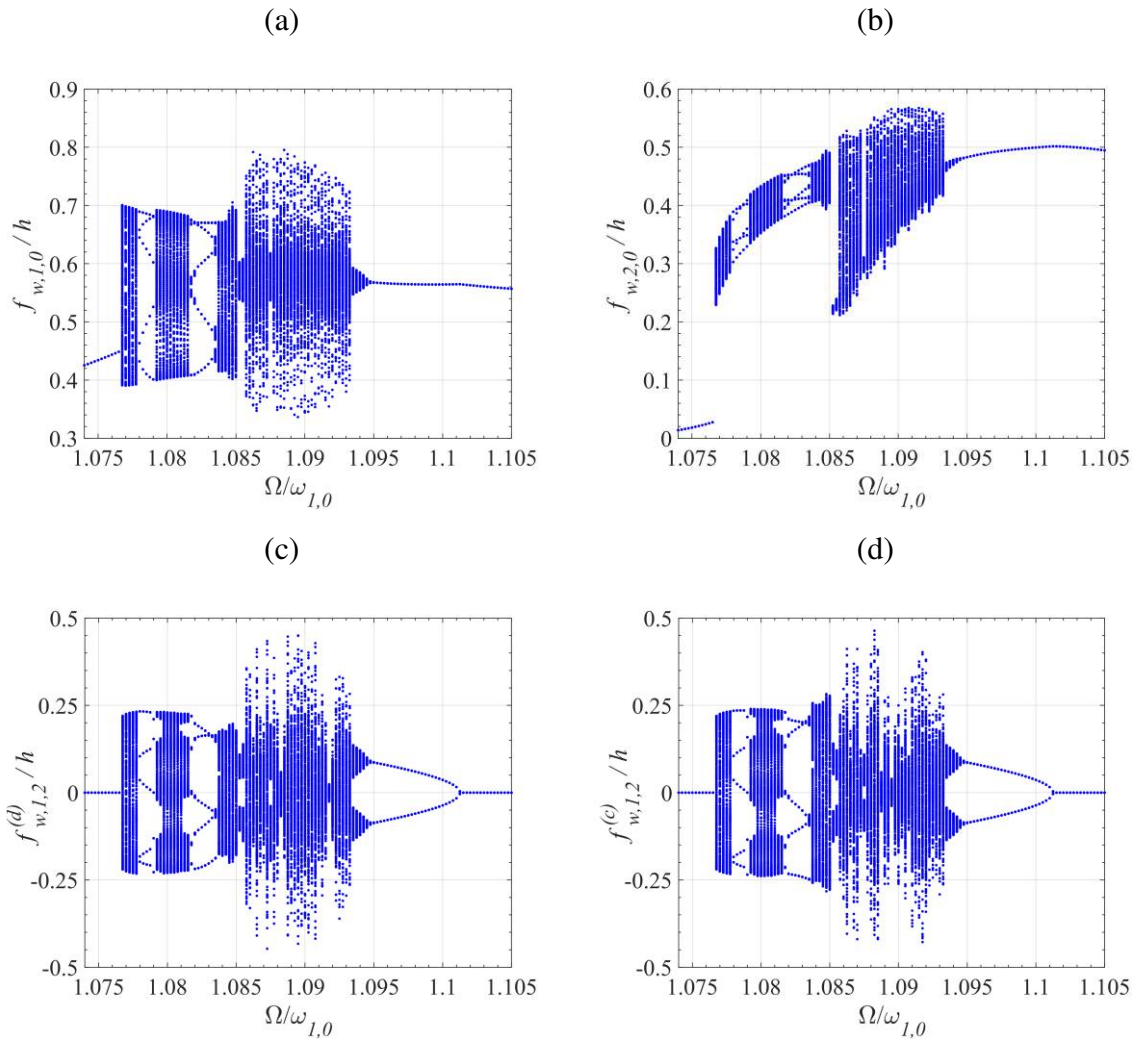

470 **Fig. 4. Bifurcation diagrams of the Poincaré section for a decreasing excitation frequency:**
 471 **(a) first axisymmetric mode, (b) second axisymmetric mode, (c) driven, and (d) companion**
 472 **asymmetric modes (1,2).**

473

474 As suggested by Moon [47], in order to detect non-periodic or chaotic oscillations
 475 it is not sufficient considering only frequency-response or bifurcation diagrams.
 476 To this end, other mathematical tools deserve to be simultaneously considered,
 477 e.g. time histories, Fourier's spectra, Poincaré sections, and phase portraits.

478 Without loss of generality, only the case of decreasing excitation frequency is
 479 here deeply investigated.

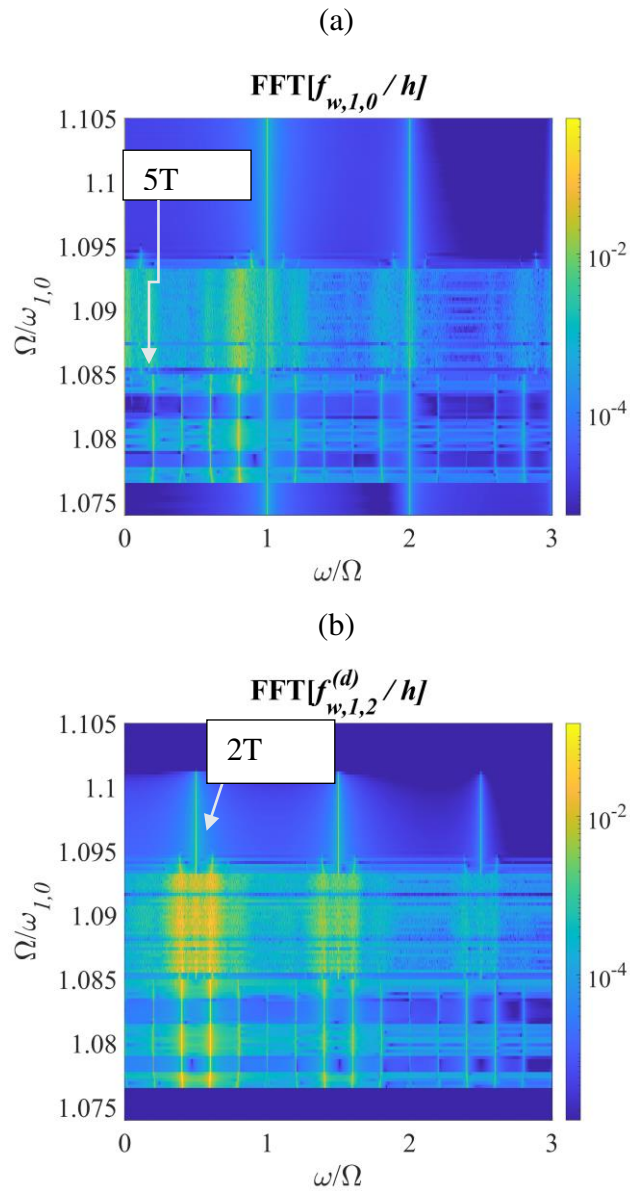

481 **Fig. 5 – Spectrograms of the modal coordinates for a decreasing excitation frequency: (a)**
 482 **first axisymmetric mode, (b) driven companion asymmetric modes (1,2).**

483

484 In Fig. 5(a) the spectrogram of $f_{w,1,0}$ is shown. The energy content is localized at
 485 the same frequency of the excitation until the instability onset, where the energy
 486 spreads on a broad frequency range. On the other hand, the response of the
 487 asymmetric mode $f_{w,1,2}^{(d)}$ is mainly $\frac{1}{2}$ -subharmonic, see Fig. 5(b). When the
 488 frequency of the harmonic pressure is decreasing and crosses $\Omega/\omega_{1,0} = 1.0850$,
 489 5T-subharmonic components of the response are clearly visible from both spectra.
 490 It is worthwhile to note that in the spectrum of $f_{w,1,2}^{(d)}$ the main 1T-harmonic is
 491 almost absent except in the frequency range of strong subharmonic vibrations.

492 In the following, the development of chaotic oscillations is shown and the
 493 behavior of the driven asymmetric mode $f_{w,1,2}^{(d)}$ is deeply addressed to complete the
 494 description of the dynamic scenario.

495 In Fig. 6(a-d) the case $\Omega/\omega_{1,0} = 1.0970$ is discussed. The driven asymmetric mode
 496 $f_{w,1,2}^{(d)}$ shows a $1/2$ -subharmonic: only odd harmonics appear in the spectrum
 497 because of the symmetry of the time waveform, Fig. 6(a,b); two points are present
 498 in the Poincaré map, Fig. 6(c); the regular limit-cycle shown by the phase portrait
 499 confirms the periodicity of the vibration, Fig. 6(d).

500

$$\Omega/\omega_{1,0} = 1.0970$$

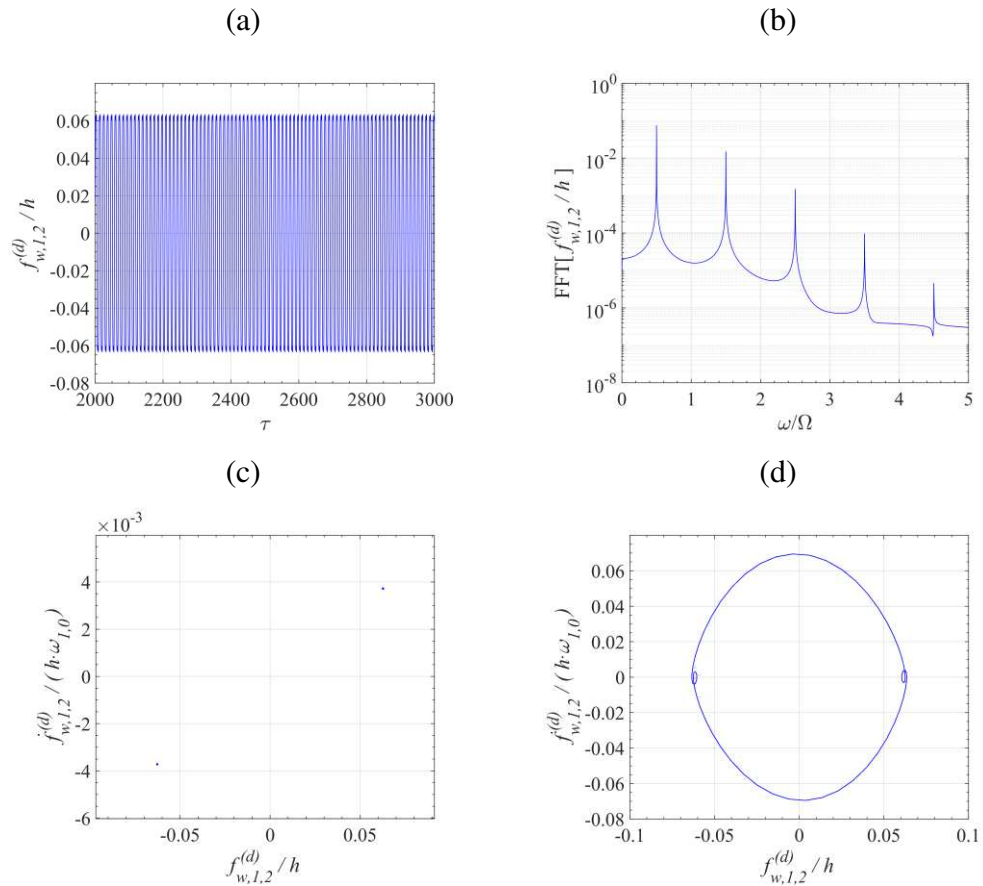

501 **Fig. 6. 2T subharmonic response of the driven modal coordinate (1,2). Decreasing excitation**
 502 **frequency. (a) Time history, (b) Fourier spectrum, (c) Poincaré map, and (d) phase portrait.**

503

504 The forcing frequency is now reduced to $\Omega/\omega_{1,0} = 1.09375$, and the system is in
 505 the un-steady region, as depicted in Fig. 4. The Neimark-Sacker bifurcation gives
 506 rise to quasi-periodic oscillations, thus the response can be seen as a sum of many
 507 periodic functions, where two or more frequencies are incommensurate [48]: in

508 this case the time response is amplitude-modulated, Fig. 7(a); the carrier
 509 frequency is $\omega/\Omega=1/2$ and sidebands (modulation frequency $\Delta\omega/\Omega=0.11$) are
 510 present, Fig. 7(b); the Poincaré map displays two closed non-connected sets,
 511 therefore the response is 2-period quasiperiodic with modulation of the amplitude
 512 [49], and the orbit does not close on itself, Fig. 7(c,d).
 513

$$\Omega/\omega_{1,0}=1.09375$$

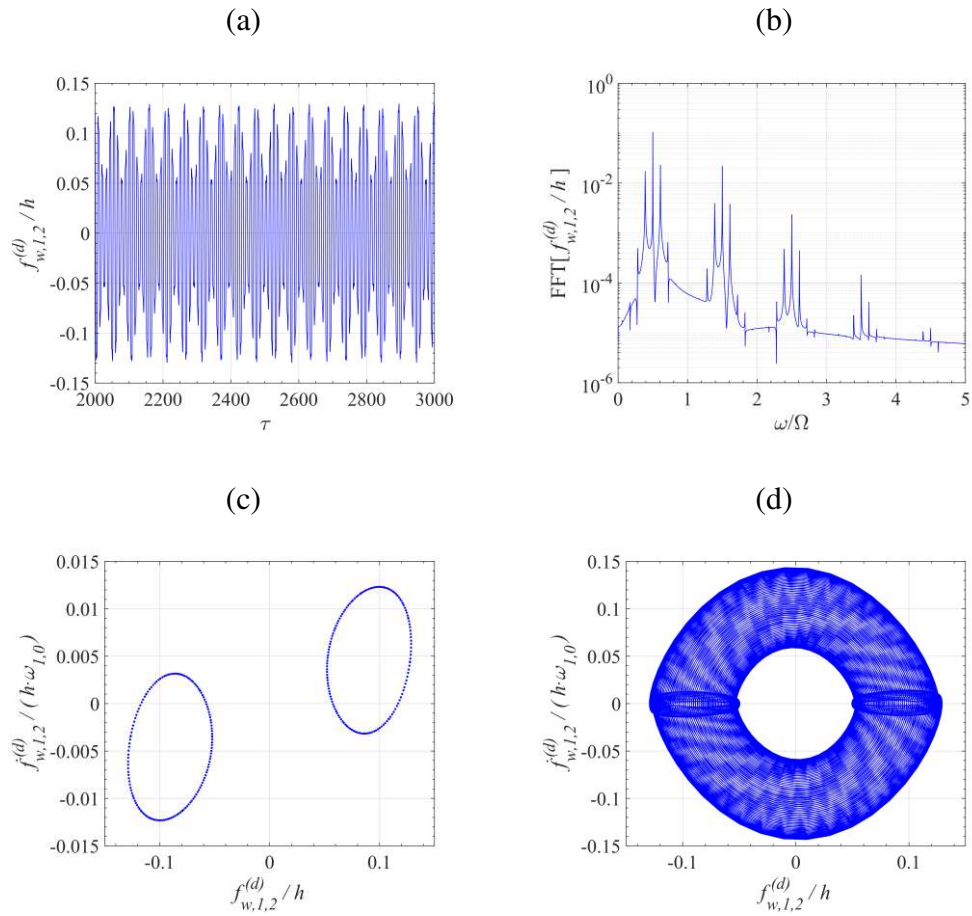

514 **Fig. 7. Amplitude-modulated response of the driven modal coordinate (1,2). Decreasing**
 515 **excitation frequency. (a) Time history, (b) Fourier spectrum, (c) Poincaré map, and (d) phase**
 516 **portrait..**

517

518

519 The case at $\Omega/\omega_{1,0}=1.0900$, is now analyzed. Chaotic vibrations can be observed:
520 the time history exhibits intermittency of the response bursts, Fig. 8(a); the
521 spectrum is characterized by a spreading of energy over a broad-band around the
522 carrier frequency (and multiples) $\omega/\Omega=1/2$, Fig. 8(b); the Poincare section
523 shows a set of randomly distributed points, where the dimension of the set does
524 not appear integer, Fig. 8(c), and the trajectory is completely irregular, Fig. 8(d).
525

$$\Omega/\omega_{1,0}=1.0900$$

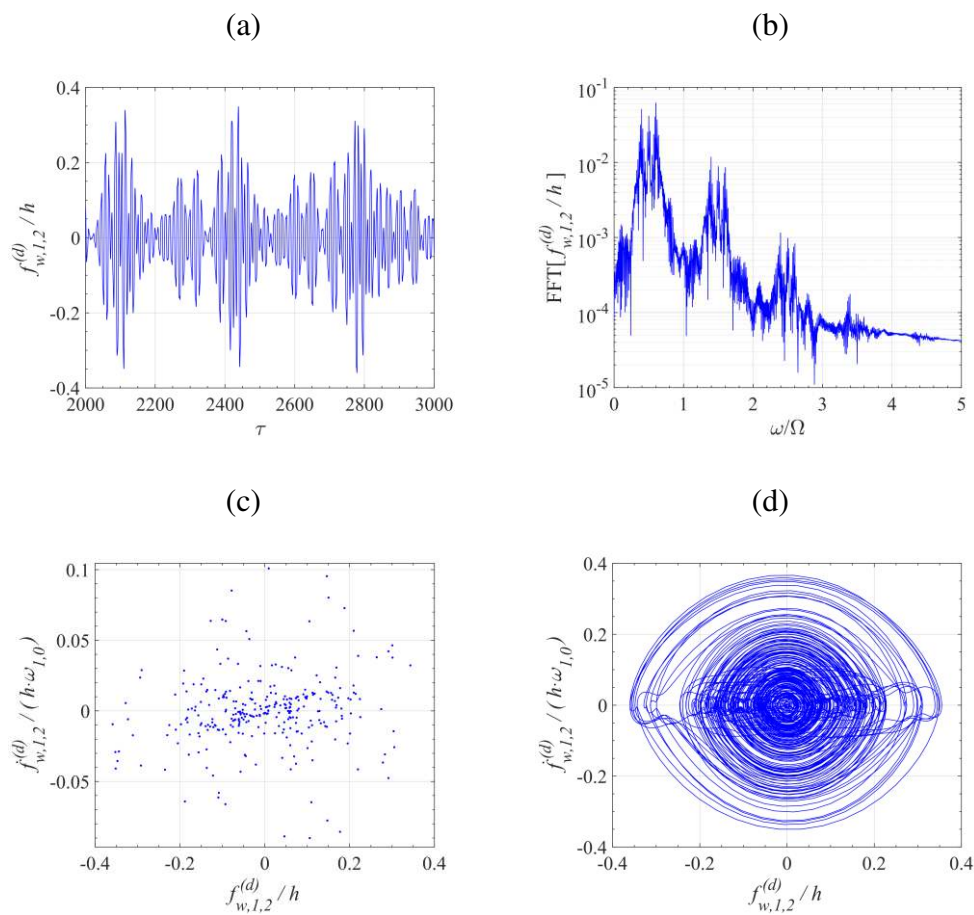

526 **Fig. 8. Chaotic response of the driven modal coordinate (1,2). Decreasing excitation**
527 **frequency. (a) Time history, (b) Fourier spectrum, (c) Poincaré map, and (d) phase portrait.**
528

529

530 Maps of chaotic motion need a larger number of points. Therefore, an additional
531 Poincaré section obtained by considering 10000 forcing periods is shown in Fig.
532 9. This map clearly shows chaotically modulated oscillations (weak chaos): the
533 central dense pattern is due to the high-frequency vibration, while the outer sparse
534 region is caused by intermittent bursts governed by a slow dynamic. Such set
535 distribution is justified by the Fourier spectrum where, despite its broad energy
536 distribution, the subharmonic components and sidebands give a significant
537 contribution to the overall dynamic of the asymmetric modal coordinate.
538

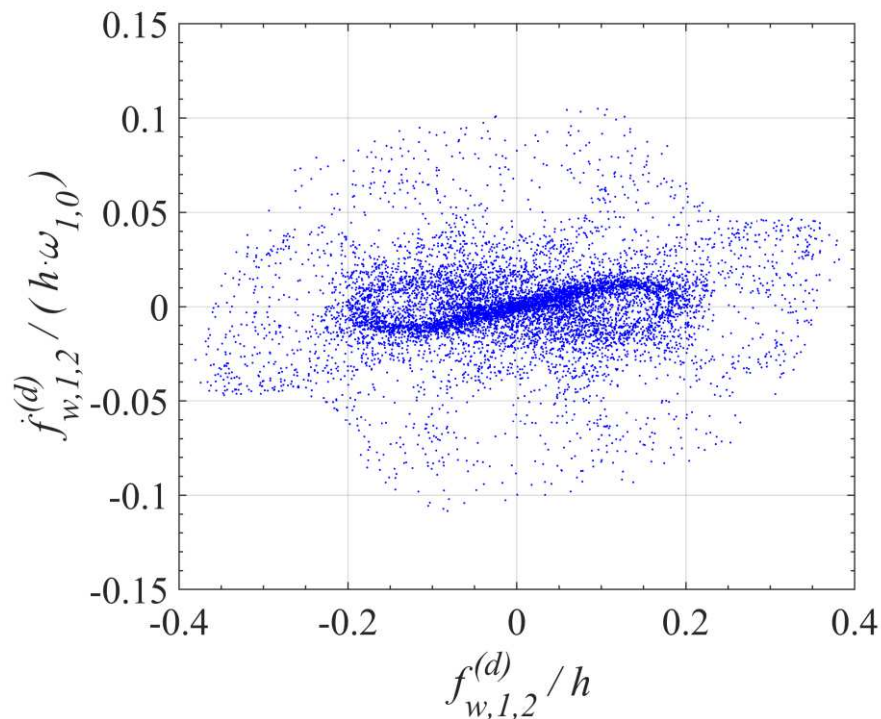

539 **Fig. 9 – Poincaré map of chaotically modulated oscillations.**

540

541 After a further reduction of the excitation frequency, the system exits from the
542 chaotic region even though it is still inside the “instability region”, where an
543 alternance of periodic and non-periodic regions is present. More specifically, the
544 case $\Omega/\omega_{1,0} = 1.0827$ is now analyzed. Here the cap response becomes 5-T
545 subharmonic: the time history appears asymptotically stable, Fig. 10(a); the
546 fundamental frequency is $\omega/\Omega = 1/5$, Fig. 10(b); the Poincaré map shows five
547 dots, Fig. 10(c); the solution follows a closed regular orbit, Fig. 10(d).

548

$$\Omega/\omega_{1,0} = 1.0827$$

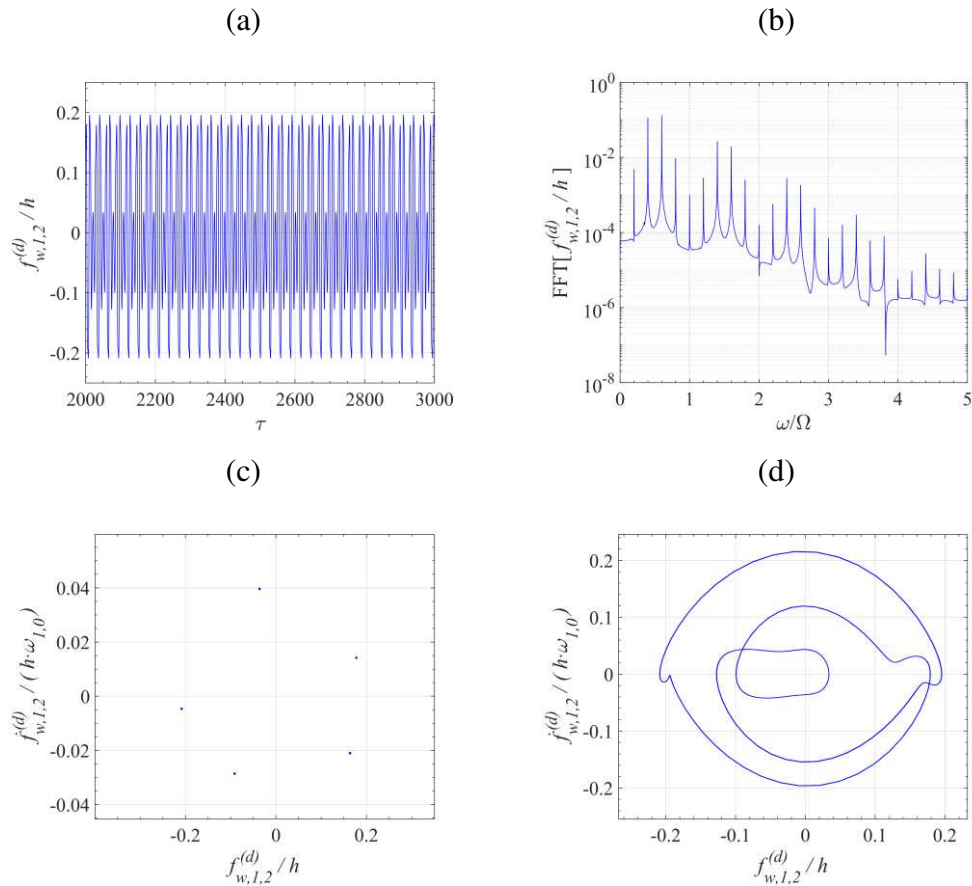

550 **Fig. 10. 5T-subharmonic response of the driven modal coordinate (1,2). Decreasing**
 551 **excitation frequency. (a) Time history, (b) Fourier spectrum, (c) Poincaré map, and (d) phase**
 552 **portrait.**

553

554 The last case to be investigated is $\Omega/\omega_{1,0} = 1.07735$. The coordinate $f_{w,1,2}^{(d)}$ exhibits
 555 quasi-periodic oscillations, where the superposition of several periodic functions
 556 can be noted by simply observing the time history, Fig. 11(a). The vibration is
 557 strongly characterized by a 1/5-subharmonic contribution Fig. 11(b); the phase
 558 portrait and the Poincaré section confirms the character of the response, Fig.
 559 11(c,d). As already shown by the frequency-response curves and the bifurcation
 560 diagrams, a further decrease in the excitation frequency restores a periodic
 561 oscillation with a null contribution of the non-symmetric modes.

562

$$\Omega/\omega_{1,0} = 1.07735$$

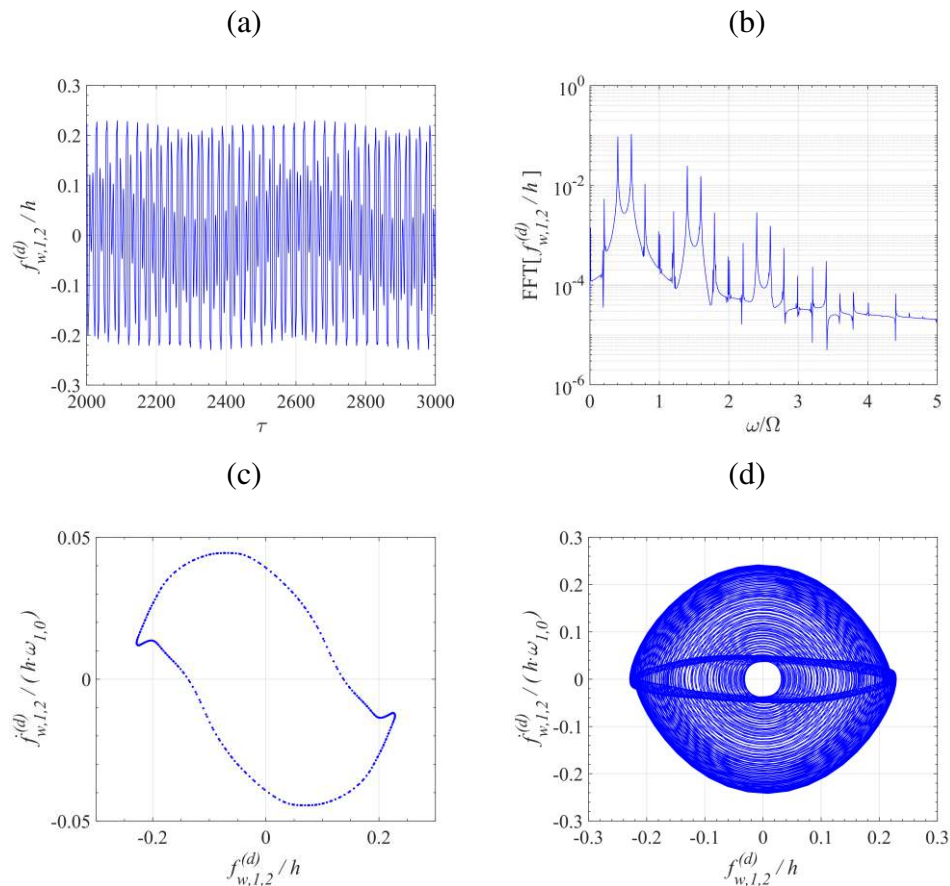

564 **Fig. 11. Quasi-periodic response of the driven modal coordinate (1,2). Decreasing excitation**
 565 **frequency. (a) Time history, (b) Fourier spectrum, (c) Poincaré map, and (d) phase portrait..**
 566

567 4. Conclusions

568 The problem of a shallow spherical cap exhibiting asymmetric oscillations when
 569 subjected to a uniform harmonic pressure has been investigated. The
 570 Novozhilov's nonlinear shell theory has been considered for defining the strain-
 571 displacement relations. The partial differential equations are reduced to a finite
 572 dimension by using an energy formulation based on Rayleigh-Ritz approach and
 573 Lagrange equations. For describing the cap deformation, the set of displacement
 574 field trial functions have been expressed by means of Legendre polynomials and
 575 trigonometric functions. A static compressive pressure has been superimposed to
 576 a harmonic one. Bifurcation diagrams are investigated against the excitation
 577 frequency. The dynamic scenario shows that the spherical cap vibrations turned

578 out to be often asymmetric, non-periodic, with multiple jumps among
579 subharmonic, quasi-periodic, and chaotic vibrations.

580

581 **Acknowledgements**

582 The authors acknowledge the University of Modena and Reggio Emilia for
583 supporting this research through the project “Interflu / Non-Newtonian Fluids and
584 Fluid-Structure Interaction”.

585

586 **Funding**

587 FAR2020 Mission Oriented - (CUP E99C20001160007).

588

589 **Conflict of Interests**

590 The authors declare they have no conflict of interests.

591

592 **Data availability**

593 Data are available from the authors upon reasonable request.

594

595 **References**

- 596 [1] Krenzke, M. A., and Kiernan, T. J., 1963, “Elastic Stability of Near-Perfect Shallow
597 Spherical Shells,” *AIAA J.*, **1**(12), pp. 2855–2857.
- 598 [2] Huang, N., 1964, “Unsymmetrical Buckling of Thin Shallow Spherical Shells,” *J. Appl.*
599 *Mech.*, **31**(3), pp. 447–457.
- 600 [3] Weinitschke, H. J., 1965, “On Asymmetric Buckling of Shallow Spherical Shells,” *J.*
601 *Math. Phys.*, **44**(1–4), pp. 141–163.
- 602 [4] Yamada, S., Uchiyama, K., and Yamada, M., 1983, “Experimental Investigation of the
603 Buckling of Shallow Spherical Shells,” *Int. J. Non. Linear. Mech.*, **18**(1), pp. 37–54.
- 604 [5] Hutchinson, J. W., 1965, *Imperfection-Sensitivity of Externally Pressurized Spherical*
605 *Shells*, National Aeronautics and Space Administration, NASA-CR-68613.
- 606 [6] Gonçalves, P. B., and Croll, J. G. A., 1992, “Axisymmetric Buckling of Pressure-Loaded
607 Spherical Caps,” *J. Struct. Eng.*, **118**(4), pp. 970–985.
- 608 [7] NASA, 1969, *Buckling of Thin Walled Doubly-Curved Shells*, National Aeronautics and
609 Space Administration, NASA SP-8032.

- 610 [8] Wagner, H. N. R., Hühne, C., and Niemann, S., 2018, “Robust Knockdown Factors for the
611 Design of Spherical Shells under External Pressure: Development and Validation,” *Int. J.*
612 *Mech. Sci.*, **141**(January), pp. 58–77.
- 613 [9] Evkin, A. Y., and Lykhachova, O. V., 2019, “Design Buckling Pressure for Thin Spherical
614 Shells: Development and Validation,” *Int. J. Solids Struct.*, **156–157**, pp. 61–72.
- 615 [10] Lock, M. H., Okubo, S., and Whittier, J. S., 1968, “Experiments on the Snapping of a
616 Shallow Dome under a Step Pressure Load,” *AIAA J.*, **6**(7), pp. 1320–1326.
- 617 [11] Stricklin, J. A., Haisler, W. E., Macdougall, H. R., and Stebbins, F. J., 1968, “Nonlinear
618 Analysis of Shells of Revolution by the Matrix Displacement Method,” *AIAA J.*, **6**(12),
619 pp. 2306–2312.
- 620 [12] Stricklin, J. A., Martinez, J. E., Tillerson, J. R., Hong, J. H., and Haisler, W. E., 1971,
621 “Nonlinear Dynamic Analysis of Shells of Revolution by Matrix Displacement Method,”
622 *AIAA J.*, **9**(4), pp. 629–636.
- 623 [13] Huang, N. C., 1969, “Axisymmetric Dynamic Snap-through of Elastic Clamped Shallow
624 Spherical Shells,” *AIAA J.*, **7**(2), pp. 215–220.
- 625 [14] Stephens, W. B., and Fulton, R. E., 1969, “Axisymmetric Static and Dynamic Buckling of
626 Spherical Caps Due to Centrally Distributed Pressures,” *AIAA J.*, **7**(11), pp. 2120–2126.
- 627 [15] Ball, R. E., and Burt, J. A., 1973, “Dynamic Buckling of Shallow Spherical Shells,” *J.*
628 *Appl. Mech.*, **40**(2), pp. 411–416.
- 629 [16] Akkas, N., 1976, “Bifurcation and Snap-through Phenomena in Asymmetric Dynamic
630 Analysis of Shallow Spherical Shells,” *Comput. Struct.*, **6**(3), pp. 241–251.
- 631 [17] Kao, R., and Perrone, N., 1971, “Asymmetric Buckling of Spherical Caps With
632 Asymmetrical Imperfections,” *J. Appl. Mech.*, **38**(1), pp. 172–178.
- 633 [18] Kao, R., 1980, “Large Deformation Elastic-Plastic Buckling Analysis of Spherical Caps
634 with Initial Imperfections,” *Comput. Struct.*, **11**(6), pp. 609–619.
- 635 [19] Kao, R., 1980, “Nonlinear Dynamic Buckling of Spherical Caps with Initial
636 Imperfections,” *Comput. Struct.*, **12**(1), pp. 49–63.
- 637 [20] Yu, Y. Y., 1964, “Generalized Hamilton’s Principle and Variational Equation of Motion in
638 Nonlinear Elasticity Theory, with Application to Plate Theory,” *J. Acoust. Soc. Am.*,
639 **36**(1), pp. 111–120.
- 640 [21] Grossman, P. L., Koplik, B., and Yu, Y., 1969, “Nonlinear Vibrations of Shallow
641 Spherical Shells,” *J. Appl. Mech.*, **36**(3), pp. 451–458.
- 642 [22] Evensen, H. A., and Evan-Iwanowski, R. M., 1967, “Dynamic Response and Stability of
643 Shallow Spherical Shells Subject to Time-Dependent Loading,” *AIAA J.*, **5**(5), pp. 969–
644 976.
- 645 [23] Yasuda, K., and Kushida, G., 1984, “Nonlinear Forced Oscillations of a Shallow Spherical
646 Shell,” *Bull. JSME*, **27**(232), pp. 2233–2240.
- 647 [24] Gonçalves, P. B., 1994, “Axisymmetric Vibrations of Imperfect Shallow Spherical Caps
648 Under Pressure Loading,” *J. Sound Vib.*, **174**(2), pp. 249–260.
- 649 [25] Gonçalves, P. B., 1993, “Jump Phenomena, Bifurcations, and Chaos in a Pressure Loaded
650 Spherical Cap Under Harmonic Excitation,” *Appl. Mech. Rev.*, **46**(11S), pp. S279–S288.

- 651 [26] Soliman, M. S., and Goncalves, P. B., 2003, "Chaotic Behavior Resulting in Transient and
652 Steady State Instabilities of Pressure-Loaded Shallow Spherical Shells," *J. Sound Vib.*,
653 **259**(3), pp. 497–512.
- 654 [27] Thomas, O., Touzé, C., and Chaigne, A., 2005, "Non-Linear Vibrations of Free-Edge Thin
655 Spherical Shells: Modal Interaction Rules and 1:1:2 Internal Resonance," *Int. J. Solids
656 Struct.*, **42**(11–12), pp. 3339–3373.
- 657 [28] Thomas, O., Touzé, C., and Luminais, É., 2007, "Non-Linear Vibrations of Free-Edge
658 Thin Spherical Shells: Experiments on a 1:1:2 Internal Resonance," *Nonlinear Dyn.*, **49**(1–
659 2), pp. 259–284.
- 660 [29] Touzé, C., and Thomas, O., 2006, "Non-Linear Behaviour of Free-Edge Shallow Spherical
661 Shells: Effect of the Geometry," *Int. J. Non. Linear. Mech.*, **41**(5), pp. 678–692.
- 662 [30] Touzé, C., Thomas, O., and Amabili, M., 2011, "Transition to Chaotic Vibrations for
663 Harmonically Forced Perfect and Imperfect Circular Plates," *Int. J. Non. Linear. Mech.*,
664 **46**(1), pp. 234–246.
- 665 [31] Krysko, V. A., Awrejcewicz, J., Dobriyan, V., Papkova, I. V., and Krysko, V. A., 2019,
666 "Size-Dependent Parameter Cancels Chaotic Vibrations of Flexible Shallow Nano-Shells,"
667 *J. Sound Vib.*, **446**, pp. 374–386.
- 668 [32] Iarriccio, G., and Pellicano, F., 2021, "Nonlinear Dynamics and Stability of Shallow
669 Spherical Caps Under Pressure Loading," *J. Comput. Nonlinear Dyn.*, **16**(2), pp. 1–8.
- 670 [33] Novozhilov, V. V., 1953, *Foundations of the Nonlinear Theory of Elasticity*, Graylock
671 Press.
- 672 [34] Leissa, A. W., 1973, *Vibration of Shells*, National Aeronautics and Space Administration,
673 NASA SP-288, Washington, D.C.
- 674 [35] de Souza, V. C. M., and Croll, J. G. A., 1980, "An Energy Analysis of the Free Vibrations
675 of Isotropic Spherical Shells," *J. Sound Vib.*, **73**(3), pp. 379–404.
- 676 [36] Leissa, A. W., 2005, "The Historical Bases of the Rayleigh and Ritz Methods," *J. Sound
677 Vib.*, **287**(4–5), pp. 961–978.
- 678 [37] Meirovitch, L., 1942, "Fundamentals of Vibration Study," *Nature*, **150**(3805), pp. 392–
679 392.
- 680 [38] Evensen, D. A., 1966, "Nonlinear Flexural Vibrations of Thin Circular Rings," *J. Appl.
681 Mech.*, **33**(3), pp. 553–560.
- 682 [39] Kubenko, V. D., Koval'chuk, P. S., and Krasnopol'skaya, T. S., 1982, "Effect of Initial
683 Camber on Natural Nonlinear Vibrations of Cylindrical Shells," *Sov. Appl. Mech.*, **18**(1),
684 pp. 34–39.
- 685 [40] Amabili, M., Pellicano, F., and Paidoussis, M. P., 1999, "Non-Linear Dynamics and
686 Stability of Circular Cylindrical Shells Containing Flowing Fluid. Part I: Stability," *J.
687 Sound Vib.*, **225**(4), pp. 655–699.
- 688 [41] Amabili, M., Pellicano, F., and Paidoussis, M. P., 2000, "Non-Linear Dynamics and
689 Stability of Circular Cylindrical Shells Containing Flowing Fluid. Part III: Truncation
690 Effect without Flow and Experiments," *J. Sound Vib.*, **237**(4), pp. 617–640.
- 691 [42] Amabili, M., 2008, *Nonlinear Vibrations and Stability of Shells and Plates*, Cambridge

- 692 University Press, Cambridge.
- 693 [43] Pellicano, F., 2007, “Vibrations of Circular Cylindrical Shells: Theory and Experiments,”
694 J. Sound Vib., **303**(1–2), pp. 154–170.
- 695 [44] Amabili, M., and Breslavsky, I. D., 2015, “Displacement Dependent Pressure Load for
696 Finite Deflection of Doubly-Curved Thick Shells and Plates,” Int. J. Non. Linear. Mech.,
697 **77**, pp. 265–273.
- 698 [45] Zoelly, R., 1915, “Über Ein Knickungsproblem an Der Kugelschale,,” ETH Zürich,
699 Zürich, Switzerland.
- 700 [46] Hairer, E., and Wanner, G., 1996, *Solving Ordinary Differential Equations II*, Springer,
701 Berlin.
- 702 [47] Moon, F. C., 2004, *Chaotic Vibrations : An Introduction for Applied Scientists and*
703 *Engineers*, Wiley-Interscience, New York.
- 704 [48] Parker, T. S., and Chua, L. O., 1987, “Chaos: A Tutorial for Engineers,” Proc. IEEE,
705 **75**(8), pp. 982–1008.
- 706 [49] Nayfeh, A. H., and Balachandran, B., 1995, *Applied Nonlinear Dynamics*, Wiley,
707 Weinheim.
- 708